

# BETRIEBSANLEITUNG

## INSTRUCTION MANUAL

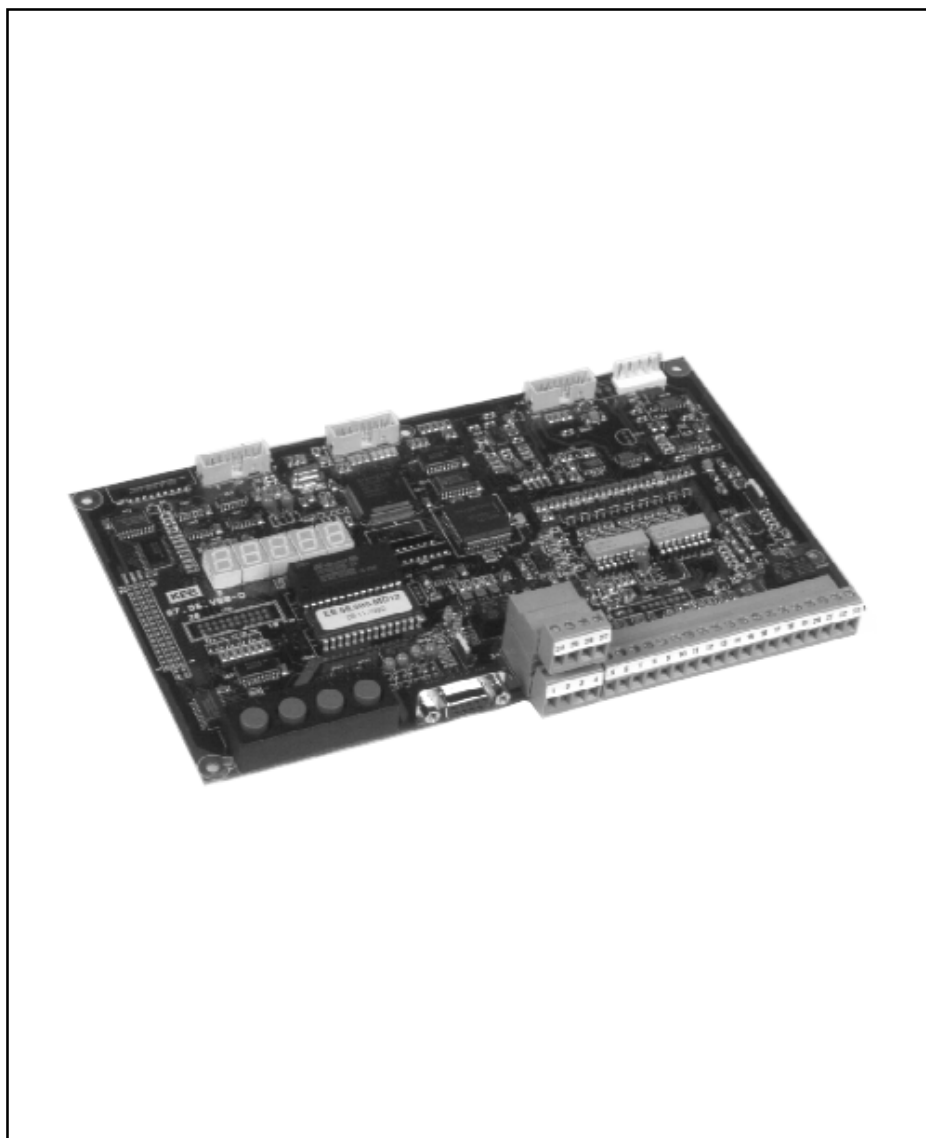

**KEB COMBIVERT 56/F1 V1.2**

**Steuerteil  
Control Circuit**

The installation shall be performed only by trained electro specialists subject to the valid regulations according to DIN VDE 0100, 0113, 0165, 0875!

Carry out the installation step-by-step. With the help of this Instruction Manual the experienced as well as the first-time user will reach the desired goal. Cross references give the user fast access to detailed explanations as well as regulations and safety instructions.

Meticulous installation carried out in conformity with the regulations as well as neat wiring protect against malfunctions and thus against time-consuming trouble shooting.

The pictographs used in this Instruction Manual have the following significance:



Danger  
Warning  
Caution

Used when life or health of the user are exposed to danger or when severe damage to the material can occur.



Direction  
Important  
Information

Special instructions for a safe and trouble-free operation.

Connection of Control Board	E 4
Operation of the Unit	E 15
Starting	E 23
Parameter	E 31
Special Settings	E 69
Annex	E 113
Index	E 123

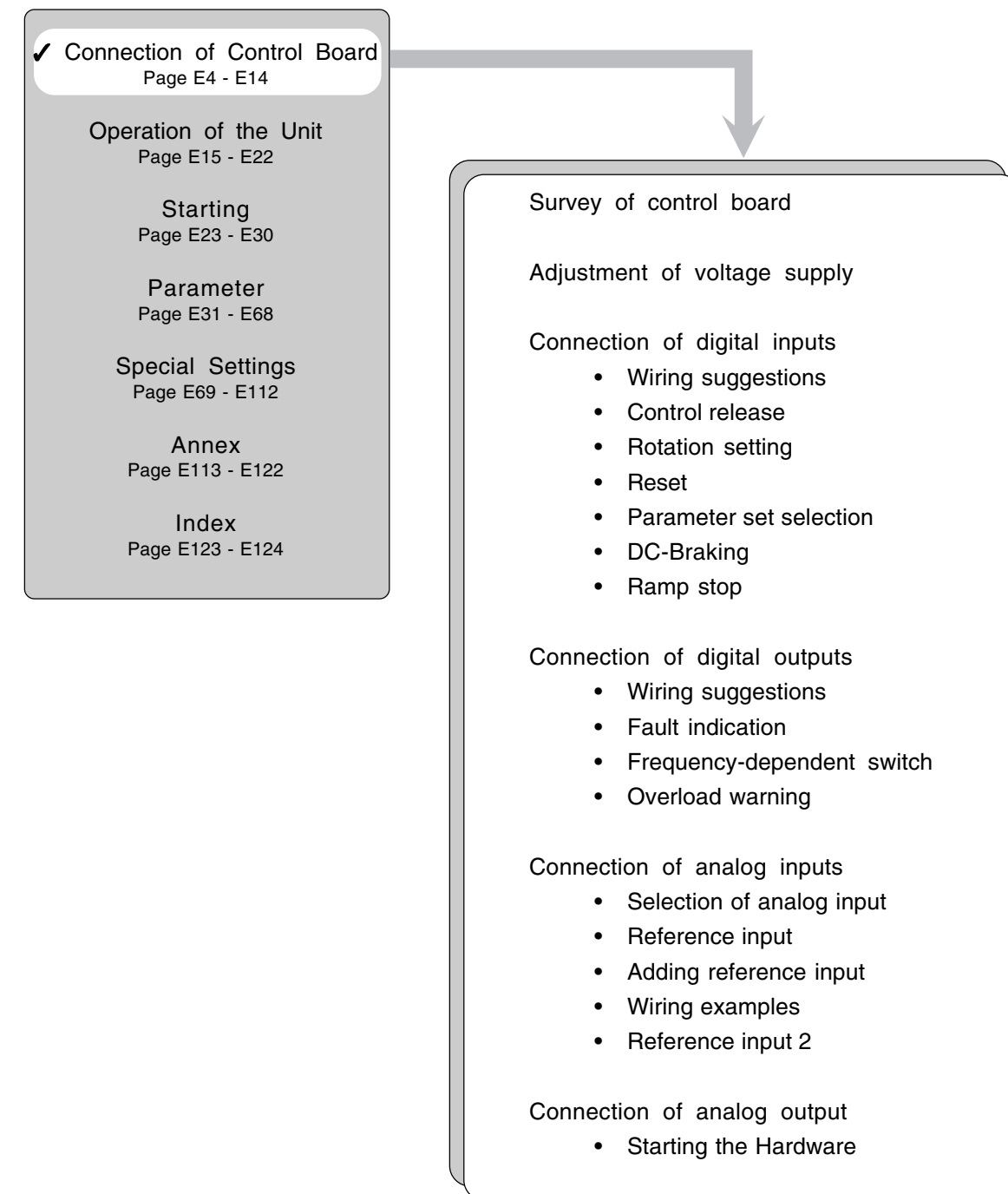

**Display**  
(at F1-units on additional board)

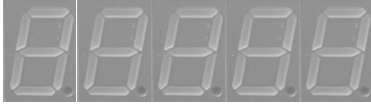

The 5figure 7-segment display represents:

Status indications:

- Inverter status (LS, nOP, etc.)
- Parameter status (e.g. FAu at wrong input)

Parameter types:

- consisting of parameter group (r, o, H, etc.) and the consecutive parameter number

Parameter values:

- show the type of parameter and the value belonging to it (e.g. deceleration time = 5.25 s)

**Keyboard**  
(at F1-units on additional board)

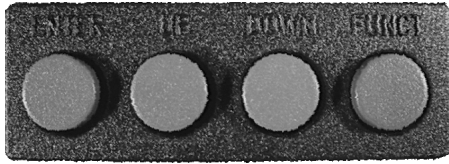

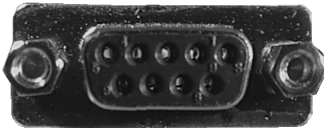

Serves for the manual operation and programming of the inverter.

**Serial Interface**

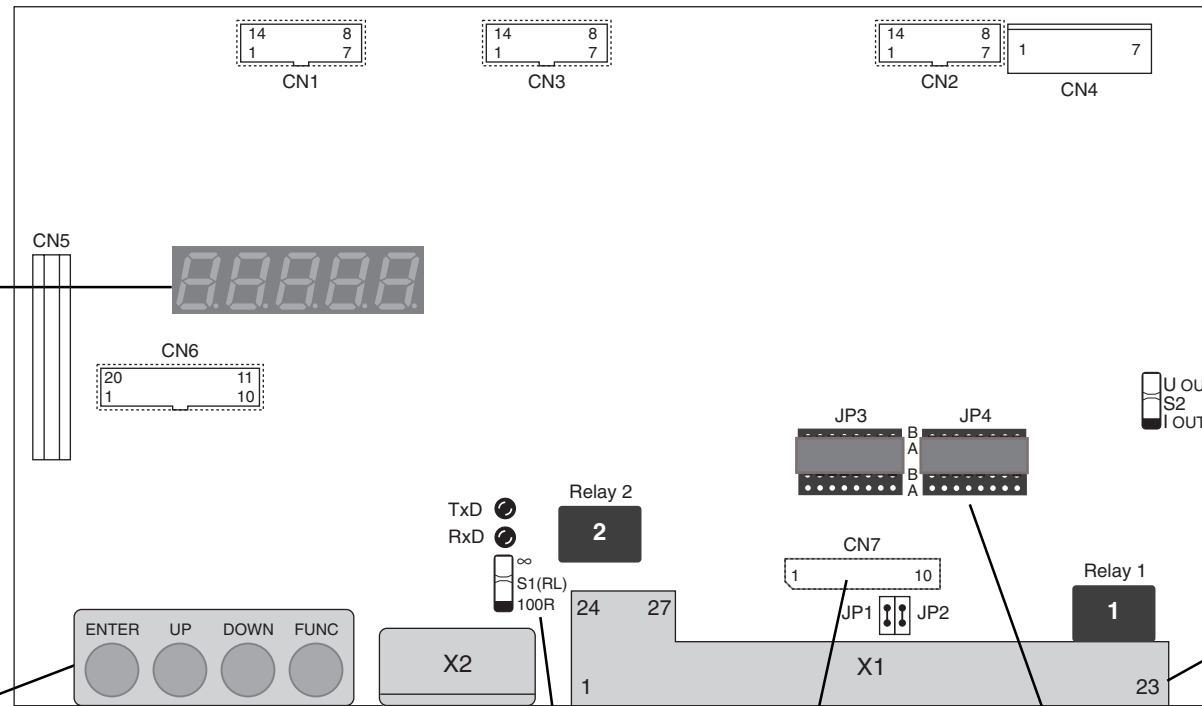

PIN No.	RS485 Ref./Norm	Signal	Meaning
1	-	+24 V	External voltage supply +24 V (Ri = 1 k $\Omega$ ) terminal 26
2	-	TxD	Transmitter signal/RS232
3	-	RxD	Receiver signal/RS232
4	A'	RxD-A	Receiver signal A/RS485
5	B'	RxD-B	Receiver signal B/RS485
6	-	VP	Voltage supply-Plus +5V (I <sub>max</sub> = 50 mA)
7	C/C'	DGND	Data reference potential
8	A	TxD-A	Transmitter signal A/RS485
9	B	TxD-B	Transmitter signal B/RS485

**U OUT**  
**S2**  
**I OUT**

Analog output

U<sub>OUT</sub> = Voltage signal  
I<sub>OUT</sub> = Current signal

TxD

RxD

$\infty$   
S1 (RL)  
100R

TxD = LED transmission control  
RxD = Reception control  
S1 = Terminating resistor (RS485)  
x = without terminating resistor  
100R > 100 $\Omega$  terminating resistor

JP3 and JP4 = Mode of triggering

Position B = PNP-triggering

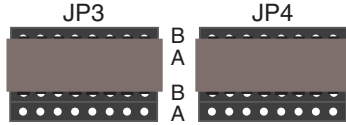

Position A = NPN-triggering

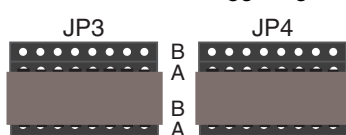

CN7

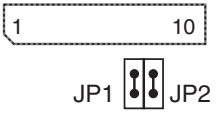

JP2 = Bridge COM / 0 V  
JP1 = Bridge 15 V / 24 V  
CN7 = Connection for options

Terminal	Description	Function
1	RLA	Programmable relay output 2, see p. E9, E78
2	RLB	
3	RLC	
4	GND	Shield connection
5	I1	Programmable inputs, see p. E6, E82
6	I2	
7	I3	
8	REF1	Analog setpoint value setting, see p. E11, E70
9	REF2	
10	F	Rotation setting, see p. E7, E70
11	R	
12	Out1	Prog. transistor output (PNP), see p. E9, E78
13	0 V	Mass for external digital wiring
14	+15 V	+15 V-output max. 100 mA
15	FRQ	Analog output signal, see p. E13, E80
16	CRF	+10 V for reference potentiometer
17	REF	Analog setpoint value setting, see p. E11, E70
18	COM	Mass (internal)
19	ST	Control release, see p. E7
20	RST	Reset, see p. E7
21	FLA	Programmable relay output 1, see p. E7, E78
22	FLB	
23	FLC	
24	Out2	Prog. transistor output (PNP), see p. E9, E78
25	Out3	
26	+24 V	Voltage supply for prog. inputs
27	I4	Programmable input, see p. E6, E82

ADJUSTMENT OF VOLTAGE SUPPLY

The control board can be triggered in different manners. The flow chart shall help you to determine the correct hardware configuration for the supply of the digital inputs and outputs as well as of the serial interface. The illustration on the opposite page gives a survey of the control board.

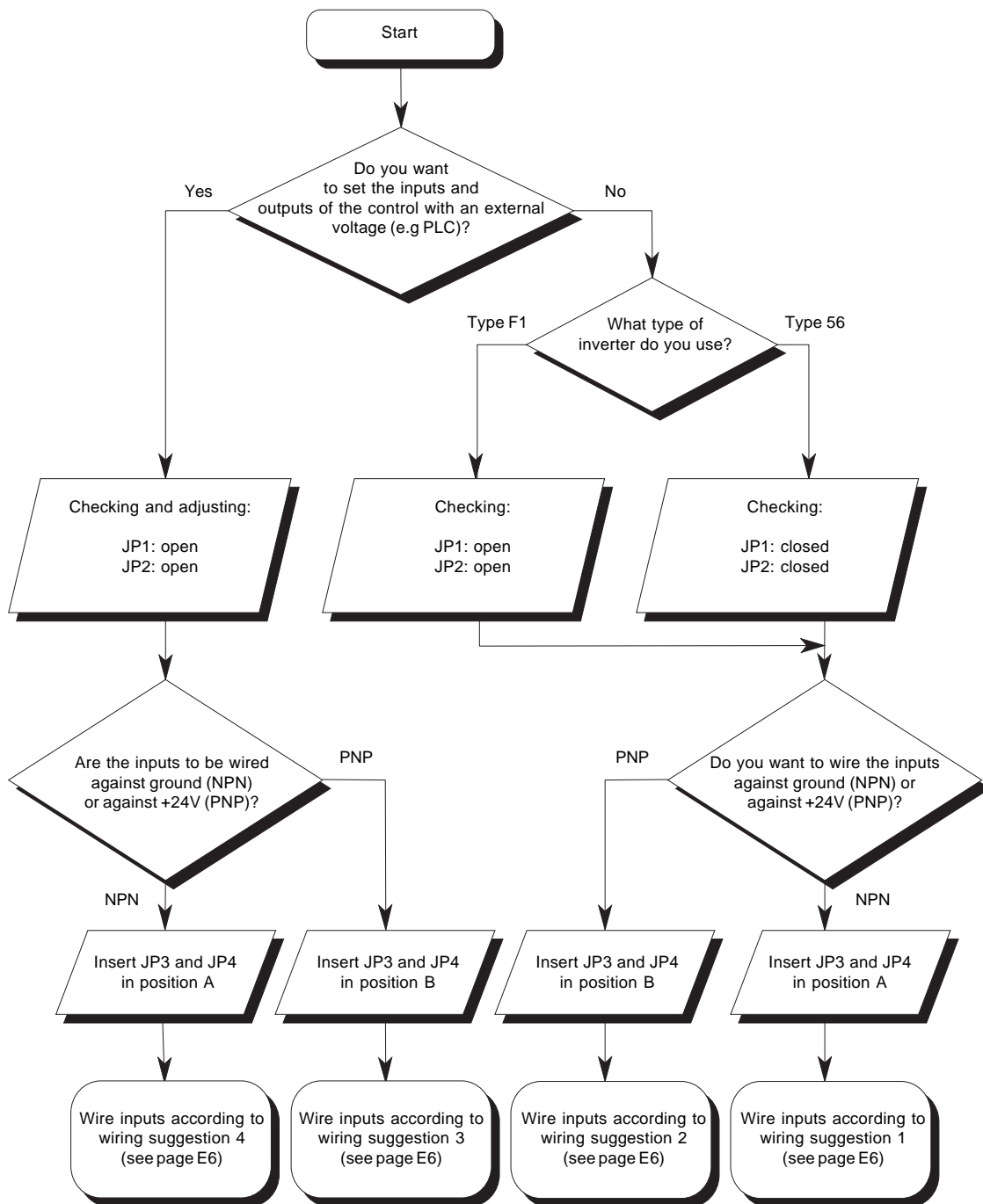

# Connection of Control Board

## CONNECTION OF DIGITAL INPUTS

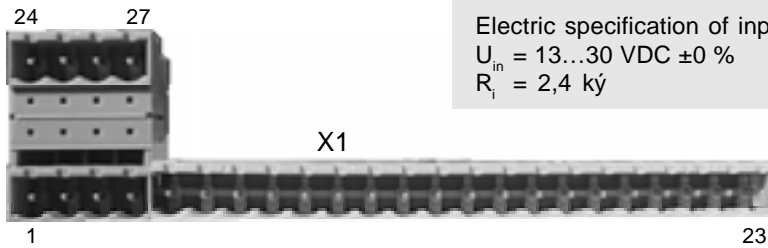

Electric specification of inputs:  
 $U_{in} = 13...30 \text{ VDC} \pm 0 \%$   
 $R_i = 2,4 \text{ k}\Omega$

### Wiring suggestion 1

NPN non-isolated at Type 56  
 (JP1/2 closed)  
 NPN isolated at Type F1  
 (JP1/2 open)

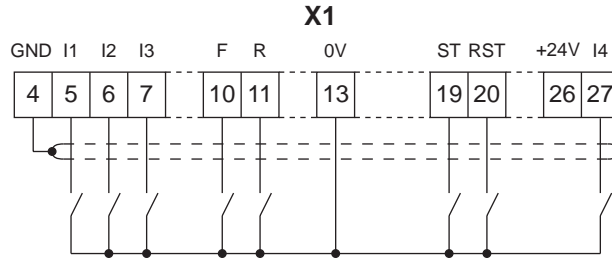

### Wiring suggestion 2

PNP non-isolated at Type 56  
 (JP1/2 closed)  
 PNP isolated at Type F1  
 (JP1/2 open)

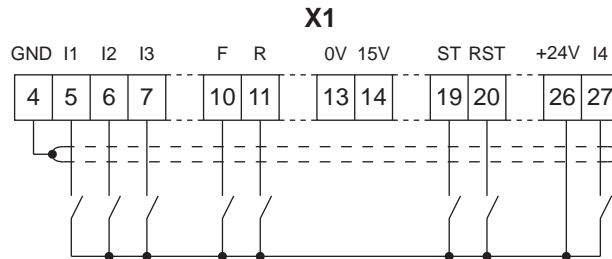

### Wiring suggestion 3

PNP isolated with external triggering  
 (JP1/2 open)



<sup>1)</sup> Wiring of this line only at Type 56!

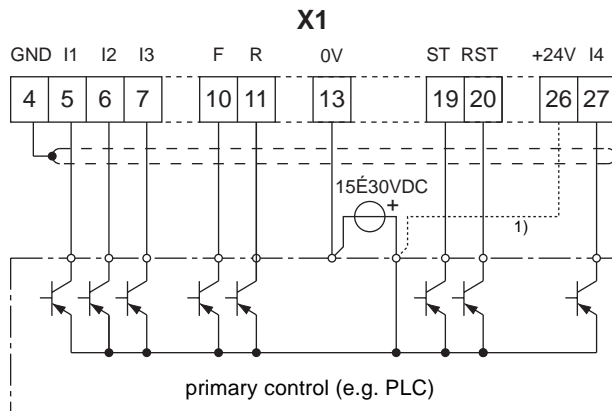

### Wiring suggestion 4

NPN isolated with external triggering  
 (JP1/2 open)



<sup>1)</sup> Wiring of this line only at Type 56!

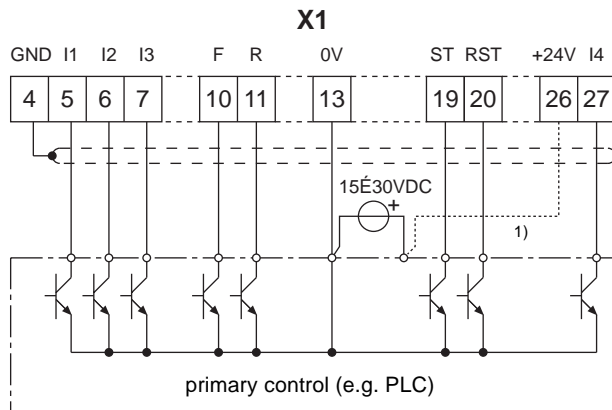

Electric specification of voltage source:

20...30 VDC  $\pm 0 \%$  (max. 3,6 V<sub>SS</sub>)  
 15...30 VDC smoothed

## Control release (ST) X1.19

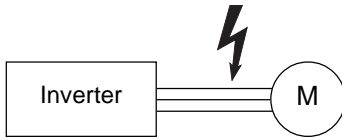

When closing the terminal X1.19 the power modules of the KEB COMBIVERT are triggered and the output is set.

When the terminal is opened during operation the motor is taken off circuit.



For maintenance and repair work the mere opening of the terminals is not sufficient as protective measure!

At running motor the terminal should be closed only when speed search (P.6) is activated.

## Rotation setting (F, R)

X1.10    X1.11

Forward      Reverse

The standard setting of the direction of rotation is done via terminal strip X1.10 and X1.11. If both terminals are triggered simultaneously then direction of rotation forward has priority. If no direction of rotation is preset the inverter is in the status Low Speed.

Alternative: With parameter C.3 the function of the terminals can be changed.

Terminal X1.10      Stop/Run

Terminal X1.11      Forward/Reverse

or: Rotation setting via keyboard/bus (see parameter r.20, o.13)

## Reset (RST) X1.20



If the inverter interrupts the operation with an error message, the error can be reset with terminal X1.20. If the terminal remains without function or if the error occurs again please refer to the chapter Error Messages to find out the cause.

## Parameter set selection (I1, I2)

X1.5    X1.6

I1      I2

Set 0...3

The KEB COMBIVERT has been programmed so that four parameter sets (e.g Multi-Step-Speed) can be selected via terminal strip. The parameter sets are activated by the terminals X1.5 and X1.6. The terminals are binary coded.

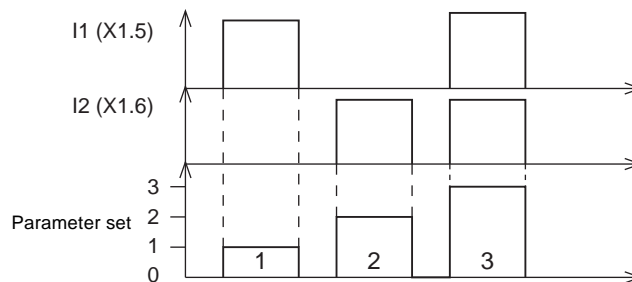

If no terminal is triggered, the inverter operates with the standard set 0.

Altogether 8 parameter sets can be programmed ∅ refer to Special Settings.

## DC-Braking (I3)

X1.7

DC-Braking allows the fast braking of the motor (e.g. quick stopping, emergency stop) . It is triggered with input X1.7. The braking time  $t_b$  is programmed for 10 s at 70 Hz and decreases in proportion to the actual frequency.

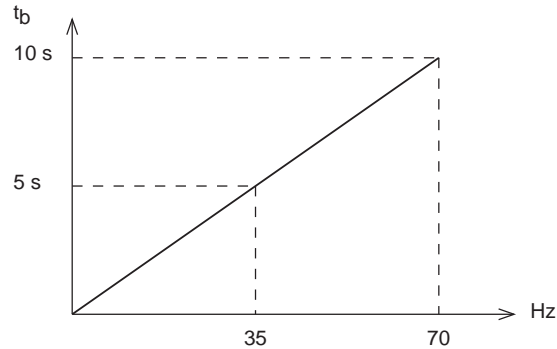

Computation  
(for standard setting)

$$t_b = \frac{10 \text{ s} \cdot \text{actual frequency}}{70 \text{ Hz}}$$

The maximum braking voltage is determined by the inverter during the braking operation. To optimally adjust DC-Braking for your application please refer to chapter Special Settings.

## Ramp stop (I4)

X1.27

If input X1.27 is set during the acceleration or deceleration phase the inverter stops the ramp immediately and holds the momentary frequency. As soon as the input is opened again the inverter continues to drive the ramp.

## Other functions

Deviating from the standard setting the inputs X1.5, X1.6, X1.7 and X1.27 can be programmed for other functions (e.g. Energy-saving function, external error).



## CONNECTION OF DIGITAL OUTPUTS

Electric specification of outputs:

T1...T3:  $U_{Out} = U_{supply} - 2,5V$  at  $I_{max}$   
 $I_{max} = 150\text{ mA}$   
 K1, K2: 250 VAC/0,2 A; 30 VDC/1A

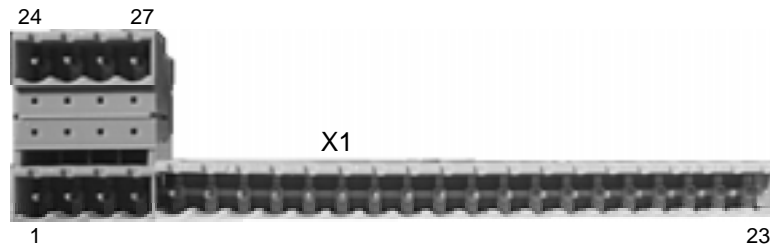

The control makes available the programmable outputs (Out1...3).

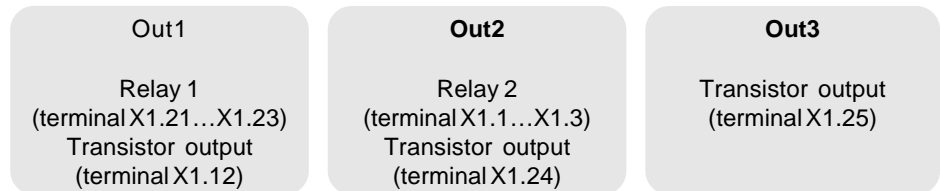

Dependent on the mode of control the transistor output supplies an output voltage of 15...30 V - 2.5 V against 0V (terminal X1.13). They can for example be used for the direct switching of the control inputs (inputs must be PNP wired).



The total current of the transistor output shall not exceed 150 mA ( $I_{T1} + I_{T2} + I_{T3} = \text{max. } 150\text{ mA}$ ).

## Connection of outputs (Example)

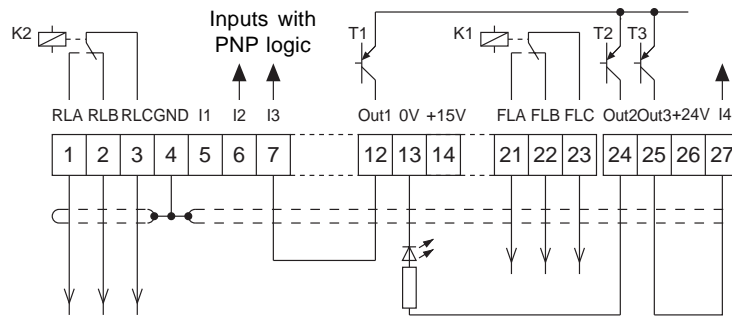

## Activation of a primary control (e.g. PLC)



<sup>1)</sup> Wiring of this line only at Type 56 and potential-separated power supply!

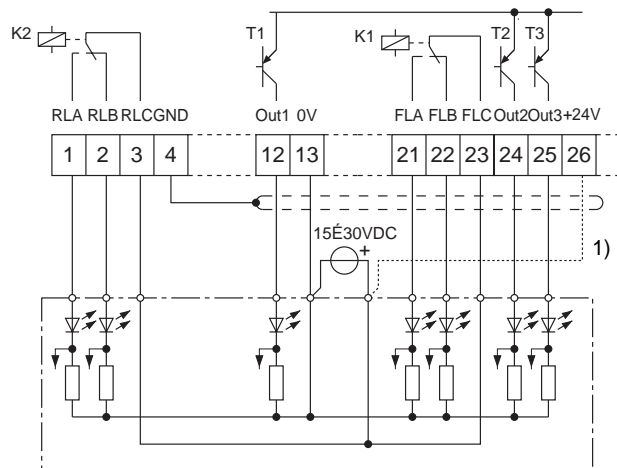

Electric specification of voltage source:

20...30 VDC  $\pm 0\%$  (max.  $3,6 V_{SS}$ )  
 15...30 VDC smoothed

## Fault indication

Out1  
Relay 1  
(terminal X1.21...X1.23)  
Transistor output  
(terminal X1.12)

Ex factory Out1 is programmed for fault indication. As soon as an error occurs that leads to the switch off of the output (U, V, W) the relay picks up and the transistor T1 switches through. The signal can be inverted with parameter H.3 (output logic). For example, a RUN-relay can be realized with it. Other functions can be programmed with parameter H.4 (Out1-function) refer to Special Settings Digital Outputs.

## Frequency-dependent switch

Out2  
Relay 2  
(terminal X1.1...X1.3)  
Transistor output  
(terminal X1.24)

Out2 is programmed as frequency-dependent switch. When actual frequency equals set frequency then the relay and the transistor T2 switch. Parameter C.28 serves for the adjustment of the switching hysteresis.

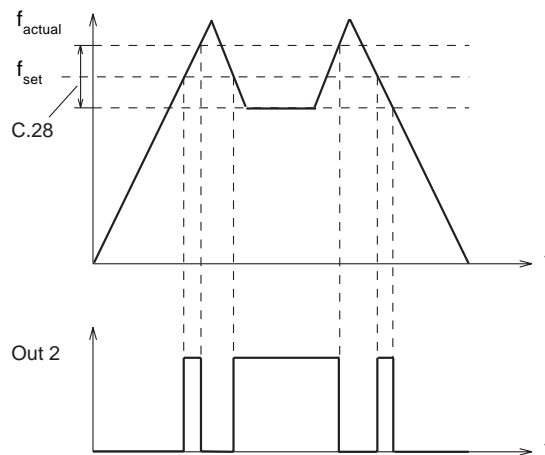

C.28 Switching hysteresis	
Range	0...100.0 Hz
Resolution	0.0125 Hz
Standard	0.5 Hz

## Overload warning

Out3  
Transistor output  
(terminal X1.25)

Out3 serves to indicate an overload before the inverter switches off.

For COMBIVERT 56D applies: Transistor T3 switches when the inverter load exceeds 130 % for approx. 20 s. If the load does not decrease the inverter switches off after another 10 s with error message OL.

For COMBIVERT F1 applies: Transistor T3 switches when the load exceeds 110 % for ca. 200 s or 130 % for ca. 80 s or 150 % for ca. 20 s. After another 100, 40 or 10 s the inverter switches off with the error message OL.

## Other functions

All control inputs can be reprogrammed for other functions, refer to Special Settings Digital Outputs.

CONNECTION OF ANALOG INPUTS

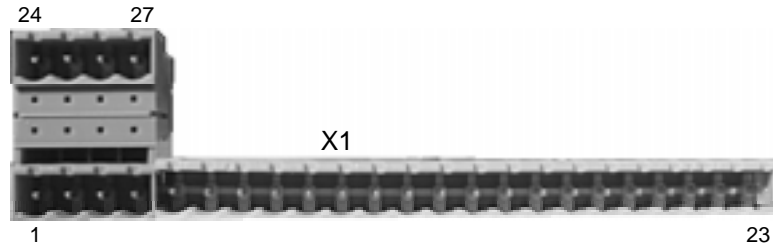

Terminal	Description	Electric specification
X1.8	REF1	$\pm 10V$ DC, $R_i = 56\text{ k}\Omega$ acts adding to REF
X1.9	REF2	0...10 VDC, $R_i = 4\text{ k}\Omega$ 0...20 mADC, $R_i = 240\ \Omega$ 4...20 mADC, $R_i = 240\ \Omega$
X1.17	REF	0...10 VDC, $R_i = 56\text{ k}\Omega$ 0...20 mADC, $R_i = 500\ \Omega$ 4...20 mADC, $R_i = 500\ \Omega$
X1.16	CRF	+10 V reference voltage $R_{Load} = 3...10\text{ k}\Omega$
X1.18	COM	internal ground connection

Selection of analog input

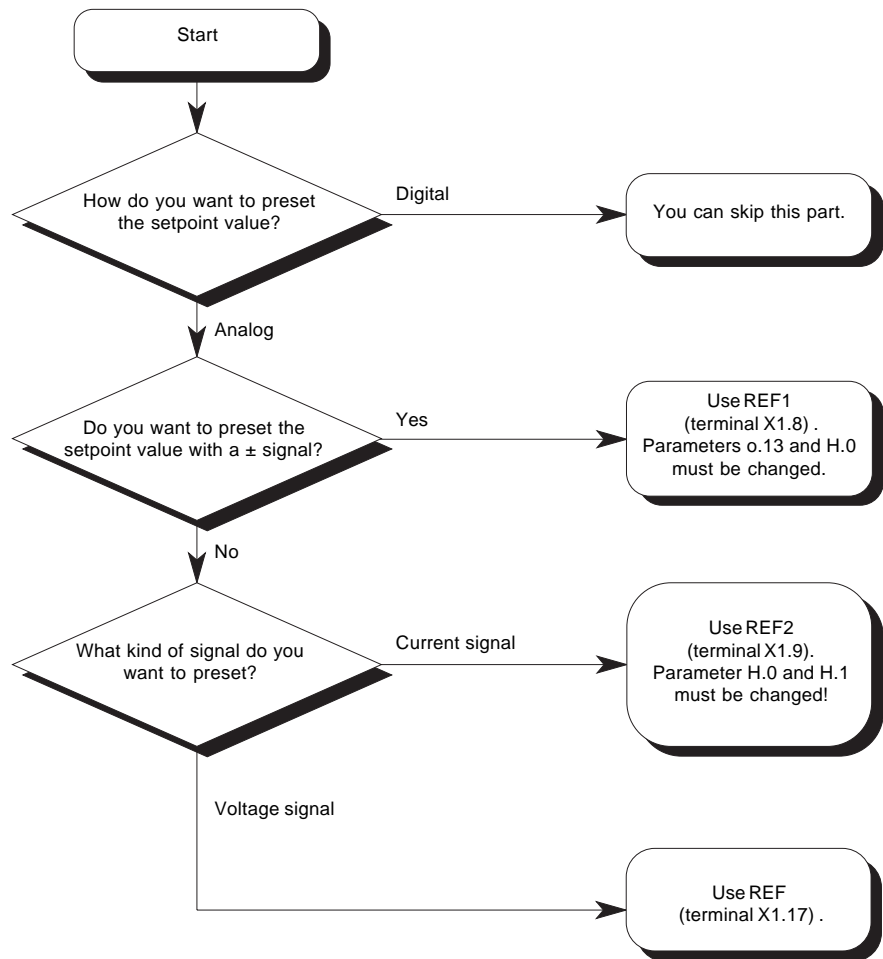

Wiring Suggestions



## Reference input (REF)

X1.17

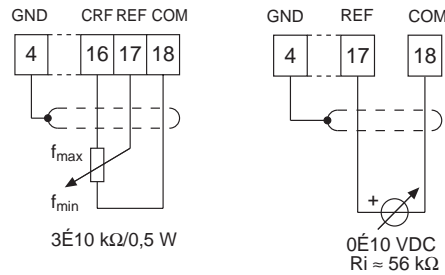

The output CRF (X1.16) makes available a short-circuit proof voltage of +10 VDC ( $R_{Load} = 3...10\text{ k}\Omega$ ).

The analog presetting of the speed at the reference input (X1.17) can be done via three different input signals.

1. 0... 10 VDC,  $R_i \approx 56\text{ k}\Omega$  (standard setting see above)
  2. 0... 20 mADC,  $R_i \approx 500\ \Omega$
  3. 4... 20 mADC,  $R_i \approx 500\ \Omega$
- } selectable with parameter H.00  
(see Special Settings)

## Adding reference input (REF1)

X1.8

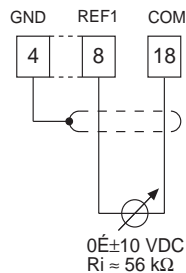

The input REF1 (X1.8) is added sign-correct to the input REF by the hardware. The sum is limited to the specified limits ( $0...10\text{ V} \triangleq f_{min}...f_{max}$ ).

## Wiring example: Setpoint setting fine/coarse

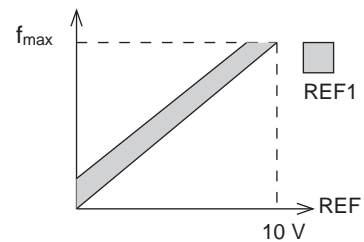
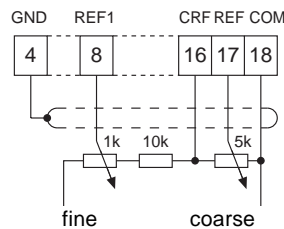

## Setpoint correction with REF1 over the entire frequency range

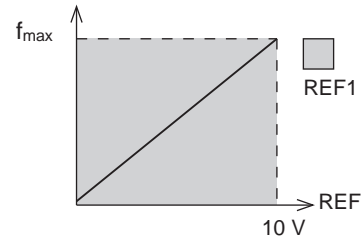
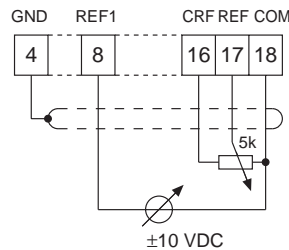

## Reference input 2 (REF2)

X1.9

Through appropriate programming the reference input 2 (X1.9) can be used for adding up or multiplication of the reference input (X1.17) (see parameter H.2). Programmed as setpoint value input it can be triggered with

1. 0... 10 VDC,  $R_i \approx 4\text{ k}\Omega$
  2. 0... 20 mADC,  $R_i \approx 240\ \Omega$
  3. 4... 20 mADC,  $R_i \approx 240\ \Omega$
- } switched on with H.0 and H.1

With its internal resistance of  $240\ \Omega$  the REF2-input is especially suited for setpoint value setting by current signal. For specific information about programming and its effect refer to Special Settings.

## CONNECTION OF ANALOG OUTPUT

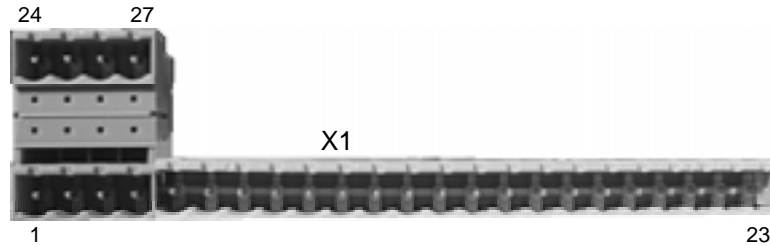

The analog output can be adapted to an extensive degree to various tasks. As standard setting the actual frequency is read out.

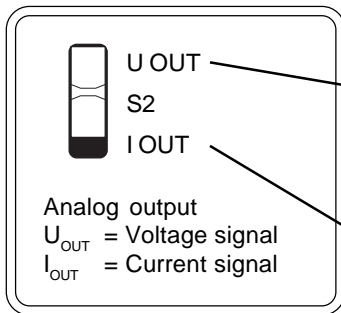

Range	Load Resistor
0...10 V	> 36 k $\Omega$ constant
0... 1 mA	< 6 k $\Omega$ constant
0...11,4 V	in no-load operation
0... 2,1 mA	at short-circuit

Range (regulated)	Load Resistor
0...20 mA	0...300 $\Omega$ constant

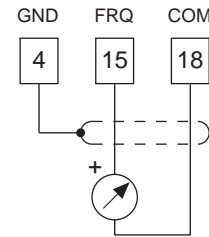

4...20 mA adjustable with parameter H.10 and H.11.

### Standard characteristic

With the standard characteristic the analog output reaches its maximum voltage at 409.58 Hz.

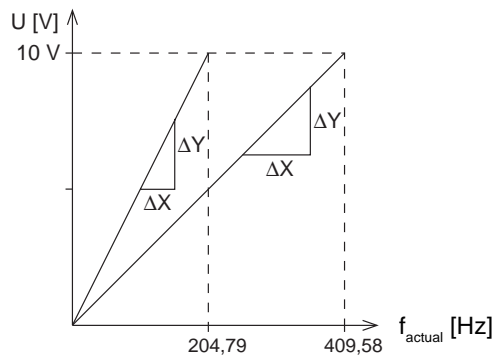

$$H.11 = \frac{\Delta Y}{\Delta X} = 1.00 \left( \hat{=} \frac{10 \text{ V}}{409.58 \text{ Hz}} \right)$$

If, for example, the analog output shall reach its maximum voltage at 204.79 Hz, then the amplification factor H.11 must be set to 2.00.

### Other functions

Among other things the setpoint frequency or the load can be represented at the analog output instead of the actual frequency. Furthermore an offset for X or Y direction can be preset. For more details refer to Special Settings *Analog Output* page E80.

## Starting the Hardware

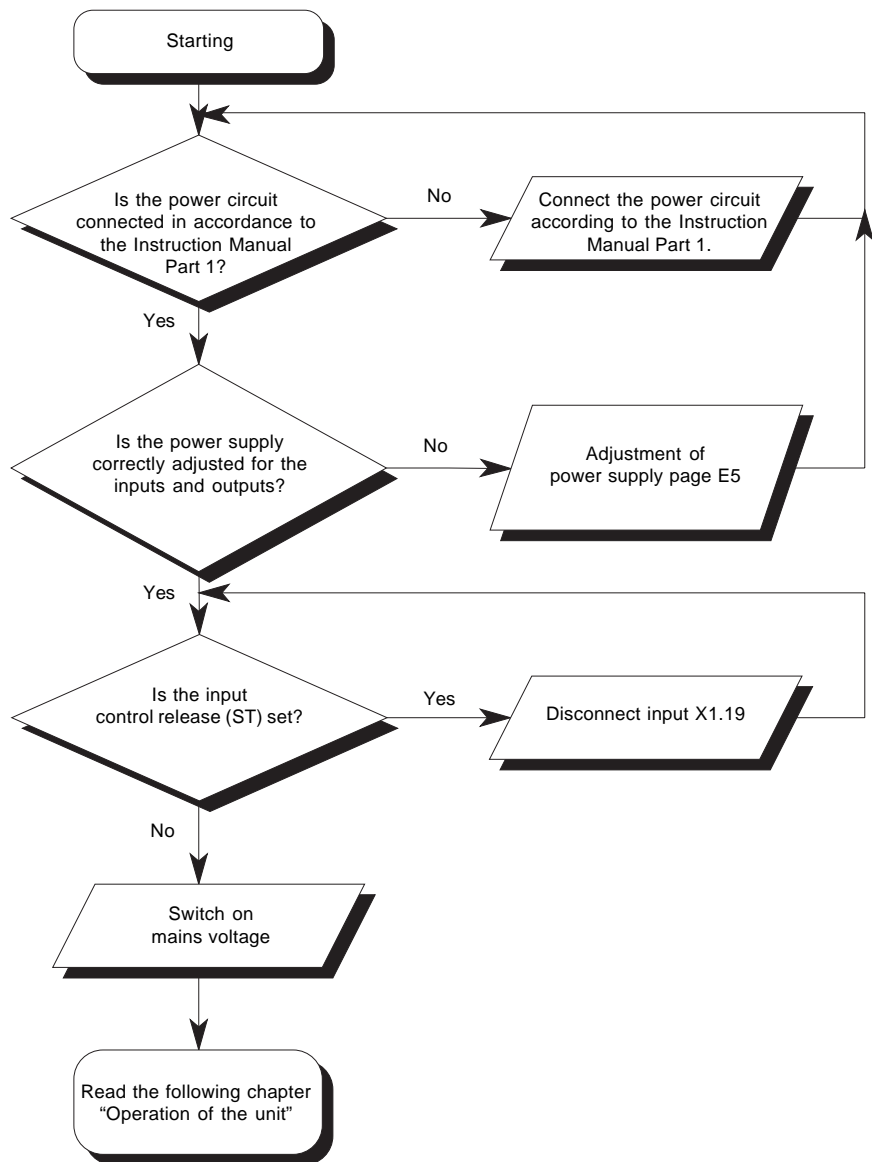

Connection of Control Board  
Page E4 - E14

✓ Operation of the Unit  
Page E15 - E22

Starting  
Page E23 - E30

Parameter  
Page E31 - E68

Special Settings  
Page E69 - E112

Annex  
Page E113 - E122

Index  
Page E123 - E124

## Fundamentals

- FUNCT-key
- UP- and DOWN-key
- ENTER-key
- ENTER-function
- Resetting of error message
- Resetting of peak values

## Recapitulation

### Password

- Password input

### Parameter sets

- not set-programmable parameters
- set-programmable parameter
- on-line/off-line

## Fundamentals

The control board offers two possibilities of access to the software.

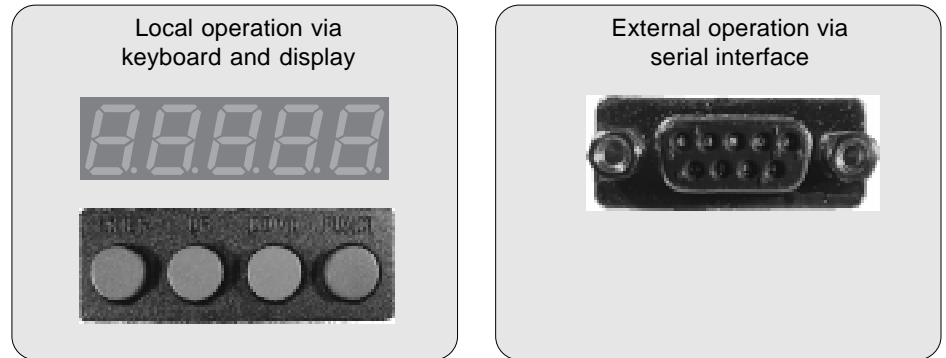

Software describes a program stored in an EPROM to control the inverter. Parameters are in/out interfaces of the program which can either indicate or influence the program run.

## FUNCT-key

A parameter consists of:

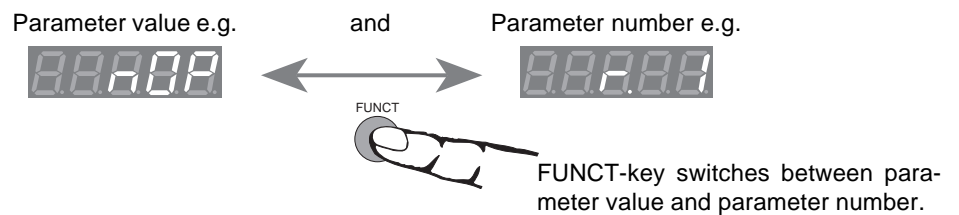

In order to make the operation easier the parameters are divided into different parameter groups. One of these parameter groups contains the (r)un-parameters. It includes all parameters that are essential for the operator of a machine.

## UP- and DOWN-key

You can select a parameter number with UP and DOWN .

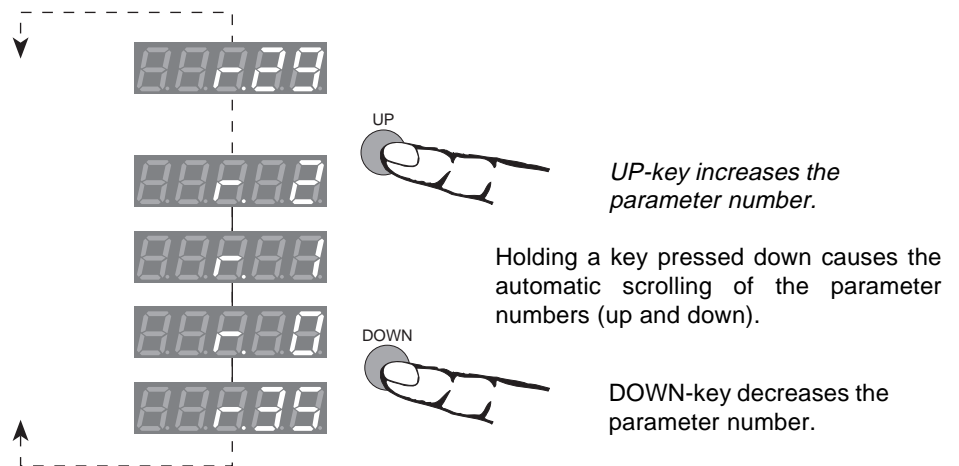

At switch on it is always jumped into the r-parameters. From here another parameter group can be selected or jumped to. For that reason the r-parameters are also referred to as

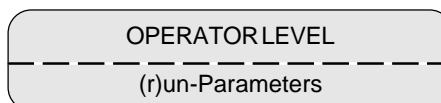



All further parameter groups are usually required only for the configuration of the drive or in the case of malfunction. Therefore these parameter groups are also called

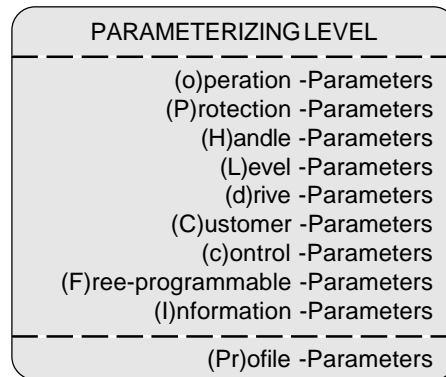

The shifting between operator and parameterizing level is done with the ENTER-key.

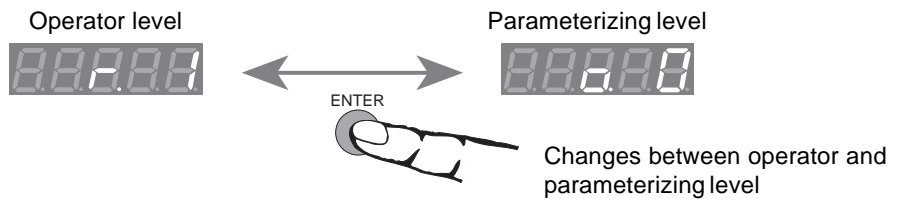

Parameter r.22 called "Select parameter group" is needed to determine the parameter group of the parameterizing level into which you are switching by pressing ENTER.

- Select parameter r.22 with UP or DOWN.
- Shift with FUNCT to the parameter value.
- Select the parameter group in which you want to jump with UP or DOWN.
- Return with FUNCT to the parameter number r.22.

The parameter value of r.22 contains the selectable parameter groups of the parameterizing level.

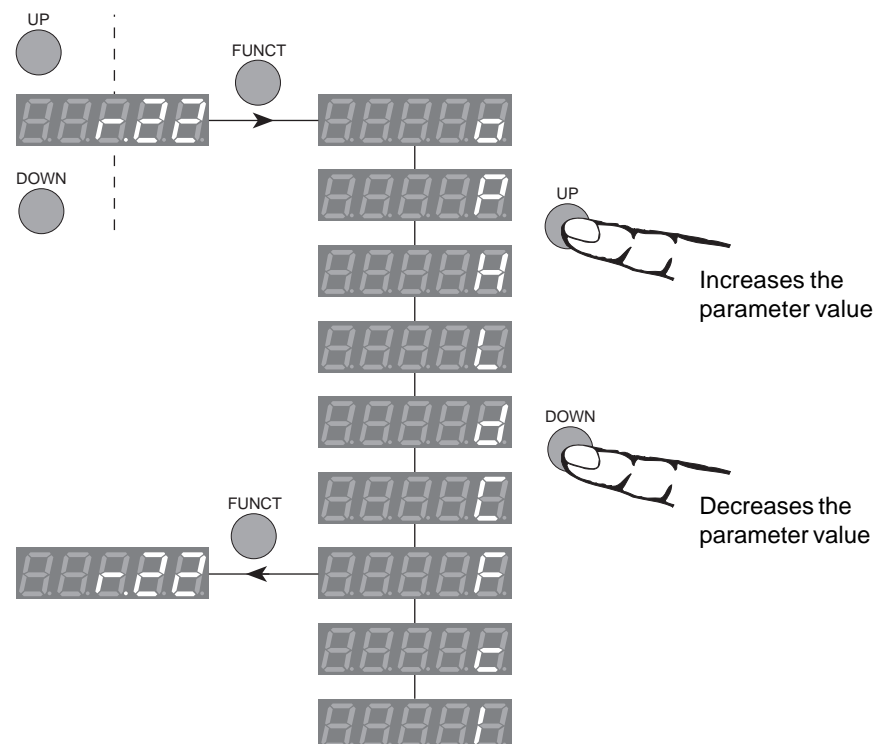

## ENTER-key

Press the ENTER-key while you are in the operator level to switch to the F-parameters.

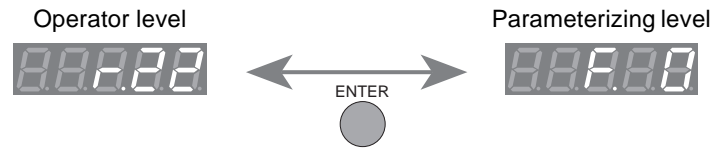

**!** The adjusted value of parameter r.22 remains active until it is changed or until the unit is switched off!

## ENTER-function

In principle changed parameter values are accepted immediately and stored non-volatile.

But for some parameters it is better that the new adjusted value is not accepted immediately. If such a parameter is changed then the display always shows a point behind the last figure.

In order for the adjusted value to be accepted press ENTER. The point disappears, the input is accepted and stored non-volatile.

### Example: Changing of ENTER-Parameters

– Change the value of r.20.

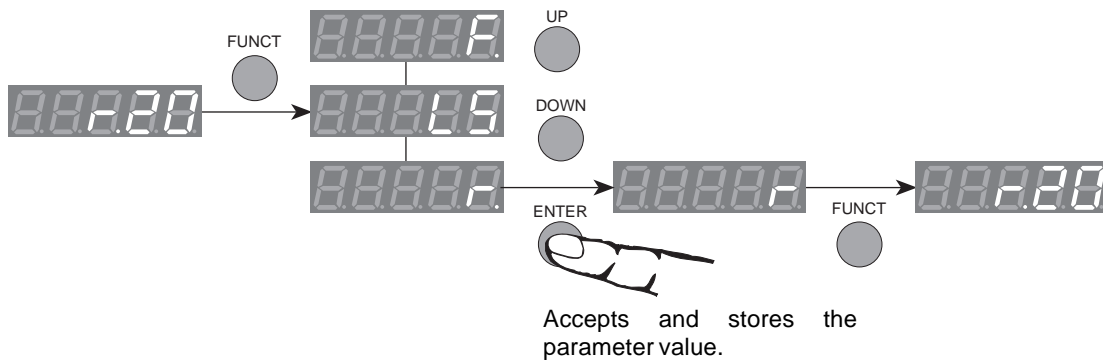

### Example: Changing of NONE-ENTER-Parameters

– Change the value of r.19.

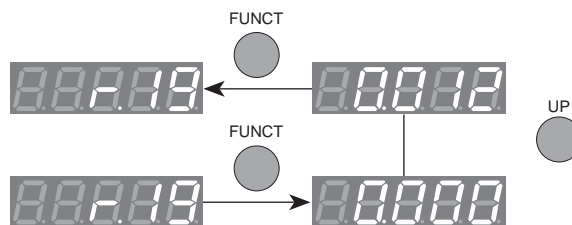

Resetting of error message

The KEB COMBIVERT can be parameterized on-line, i.e. parameters can be changed while the drive runs. If for example an error occurs at the optimization of the drive, the error overwrites the current display indication independent of the parameter number or value.

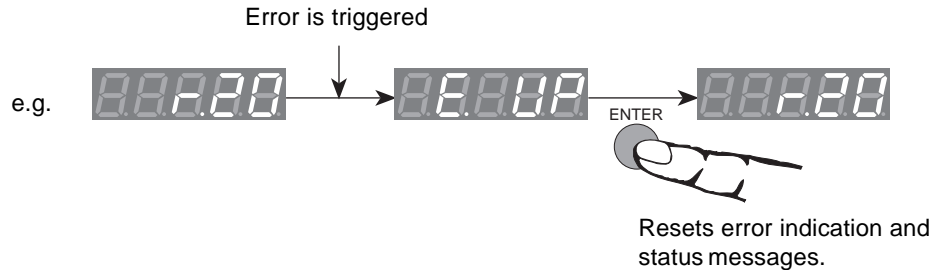

ENTER only resets the error indication. To reset the error itself the error cause must be eliminated first and a reset at terminal X1.20 or a cold start must be carried out.

Resetting of peak values

In order to draw conclusions on the operational performance of the drive there are parameters that indicate the peak values. Peak value means that the highest measured value is stored for the operation time of the inverter. With ENTER the peak value can be reset. Thus it is possible to determine in a simple manner e.g. with parameter r.8 the maximum load at different inverter settings.

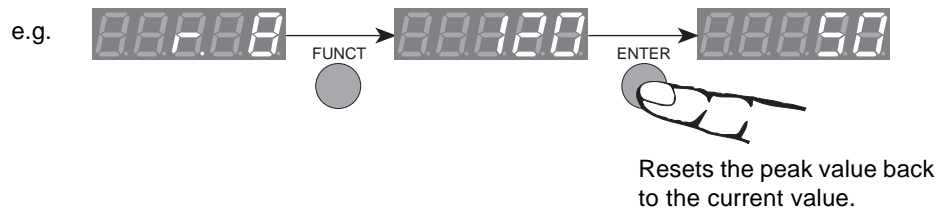

RECAPITULATION

<p>ENTER</p>	<p>UP      DOWN</p>	<p>FUNCT</p>
<ul style="list-style-type: none"> <li>- changes between operator and parameterizing level</li> <li>- accepts and stores ENTER-parameters</li> <li>- resets error indication and status message</li> <li>- resets peak value</li> </ul>	<ul style="list-style-type: none"> <li>- increases/decreases parameter number</li> <li>- increases/decreases parameter value</li> </ul>	<ul style="list-style-type: none"> <li>- changes between parameter number and parameter value.</li> </ul>

## PASSWORD

To protect the inverter against maloperation by unauthorized personnel a password must be entered prior to parameterizing. 3 password levels (e.g. for machine builder, service personnel, final user) were defined in order to meet the safety requirements.

3 attempts are allowed for the correct input of the password. After that the password input is disabled, it can be reactivated only by switching the unit off and on again (display must be dark).

The password is cancelled 30 minutes after the last key actuation and must be entered again for further changes.

The password protection is reactivated by entering 999 .

### Password input

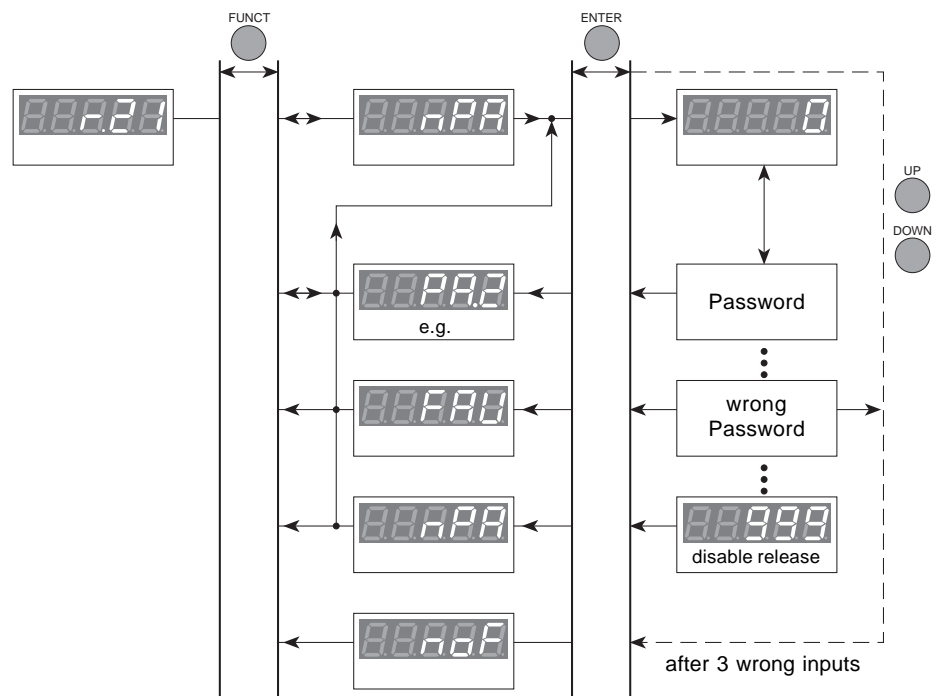

Possible status messages:

nPA	=	no Password entered
PA.1...PA.3	=	Password level 1...3 enabled
FAU	=	wrong Password
noF	=	no further function (after 3 wrong inputs)

- Parameter group locked
- x Parameter group enabled
- <sup>1)</sup> Parameter group can be locked with C.9, normally enabled.
- <sup>2)</sup> Exception: F.3 requires password level PA.3.

Password Structure		Parameter Groups									
Level	Password	c	C	d	L	H	P	o	r	F <sup>2)</sup>	I
nPA	no Password	-	-	-	-	-	-	-	<sup>1)</sup>	x	x
PA.1	Set-up Password	-	-	-	<sup>1)</sup>	<sup>1)</sup>	<sup>1)</sup>	<sup>1)</sup>	<sup>1)</sup>	x	x
PA.2	User Password	-	-	-	x	x	x	x	x	x	x
PA.3	Customer Password	x	x	x	x	x	x	x	x	x	x

The passwords are listed on page E119.

## PARAMETER SETS

The software incorporates 8 parameter sets (0...7) that can be selected over terminal strip, keyboard or bus. Two parameters form the basis for the handling of the parameter sets,

 and  for local operation (keyboard operation),  
 and  for bus operation.

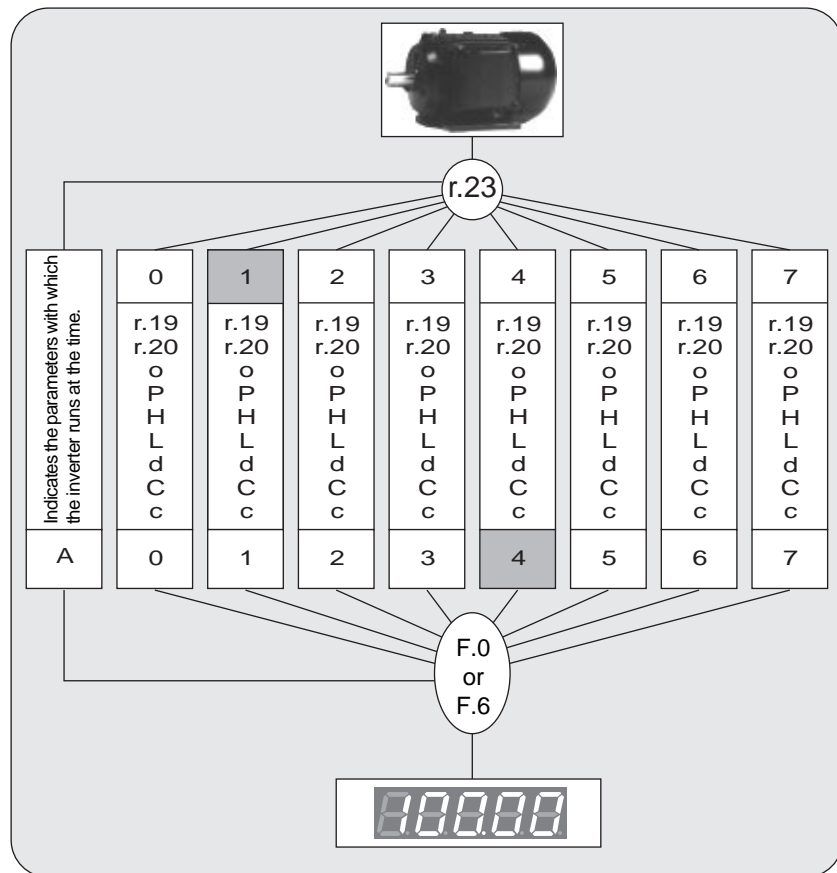

## Principle

**Example:** Inverter runs with set 1 (r.23 = 1); the display shows the parameters of set 4 (F.0 = 4).



– Indication of the parameter set with which the inverter (motor) runs at the time.

– Activation of a parameter set with which the inverter (motor) shall be running. (Only possible when parameter set selection is set to “o.18 = 1 or 2” by keyboard or bus.)

 or   
 (Keyboard operation)      (Bus operation)

– Selection of a parameter set that shall be displayed or parameterized. The standard setting displays set 0.

– Definition that the active set (r.23) is always displayed (F.0 or F.6 = A).



If A is adjusted in F.0 or F.6 the parameters can only be displayed but not changed.

## Not set-programmable parameters

Among the parameter groups there are parameters where differing programming in the sets is not possible. Thus e.g. the differing assignments of the inputs in different sets is being avoided.

The following parameters are not set-programmable, i.e. their value is identical in every parameter set. However, it is possible to change these parameters from every set.

o.18	H.0	C.4	c.10
	H.7	C.5	c.11
P.18	H.12	C.9	c.12
	H.13	C.12	c.13
	H.14	C.13	c.14
	H.15	C.21	c.15
	H.16	C.25	c.16
	H.17	C.29	c.17
		C.30	c.18
		C.31	c.19
		C.32	c.20
		C.33	c.21
		C.34	c.22
			c.23

## Set-programmable parameters

All other parameters of the parameter groups o, P, H, L, d, C, c as well as r.19 and r.20 can be programmed differently in each set.

## On-line/Off-line

All parameters can be programmed on-line and off-line.

*On-line:* The parameter set to be programmed is active ( $r.23 = F.0/F.6$ ) and control release is switched.

*Off-line:* The parameter set is not active ( $r.23 \neq F.0/F.6$ ) or control release is not switched.

## Connection of Control Board

Page E4 - E14

## Operation of the Unit

Page E15 - E22

## ✓ Starting

Page E23 - E30

## Parameters

Page E31 - E68

## Special Settings

Page E69 - E112

## Annex

Page E113 - E122

## Index

Page E123 - E124

## Operation display

## Digital rotation and reference setting

- Reference setting (digital)
- Rotation setting (digital)
- Select parameter set

## Reference limits

- Setting range
- Limit of maximum reference

## Ramp setting

- Setting range
- Calculation

## S-curves

- Setting range
- Mode of functioning

## Boost/Delta-Boost

- Boost
- Delta-Boost
- Delta-Boost/time







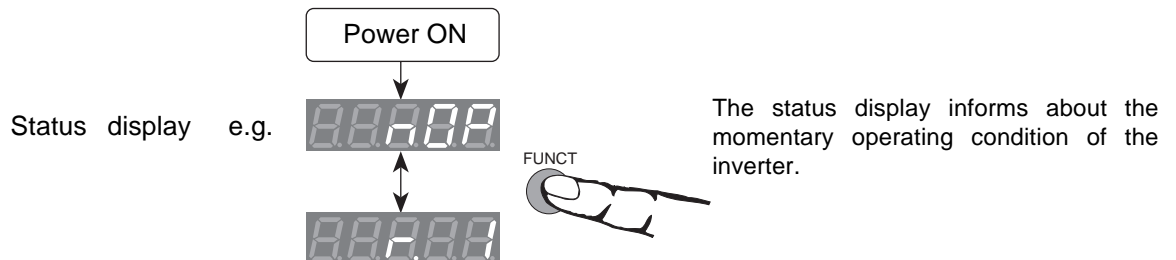











## OPERATION DISPLAY

After switching on the KEB COMBIVERT a parameter value of the operator level appears in the display. For the KEB factory setting it is the parameter value of parameter r.1 (status display).

However, any other r -Parameter can be defined to appear in the operation display (see parameter C.4).



*Possible status displays:*

-  No control release; terminal X1.19 not activated.
-  No rotational direction preset by terminal strip or bus.
-  No rotational direction preset with DRIVECOM-control word.
-  Forward acceleration
-  Forward deceleration
-  Constant run forward
-  Reverse acceleration
-  Reverse deceleration
-  Constant run reverse
-  Speed search active (see P.6 or Special Settings Speed Search).
-  Ramp stop active during acceleration (see P.13 or Special Settings Ramp Stop).
-  Ramp Stop active during deceleration (see P.13 or Special Settings Ramp Stop).
-  Stall function active (see P.0 or Special Settings Stall Function).
-  DC-Brake active
-  DC-Brake; Braking time expired after taking away the rotational direction.
-  Motor de-excitation time elapses; before activating e.g. DC-Brake the motor must be de-excited.
-  Error message (see Annex Error Messages).
-  Power-Off Function active (see Special Settings Power-off).



DIGITAL ROTATION AND REFERENCE SETTING

If the rotation direction and/or the reference value are to be preset by keyboard or bus, which deviates from the KEB factory setting, then parameter o.13 (input source) must be changed as follows:

K = Keyboard/Bus  
T = Terminal strip

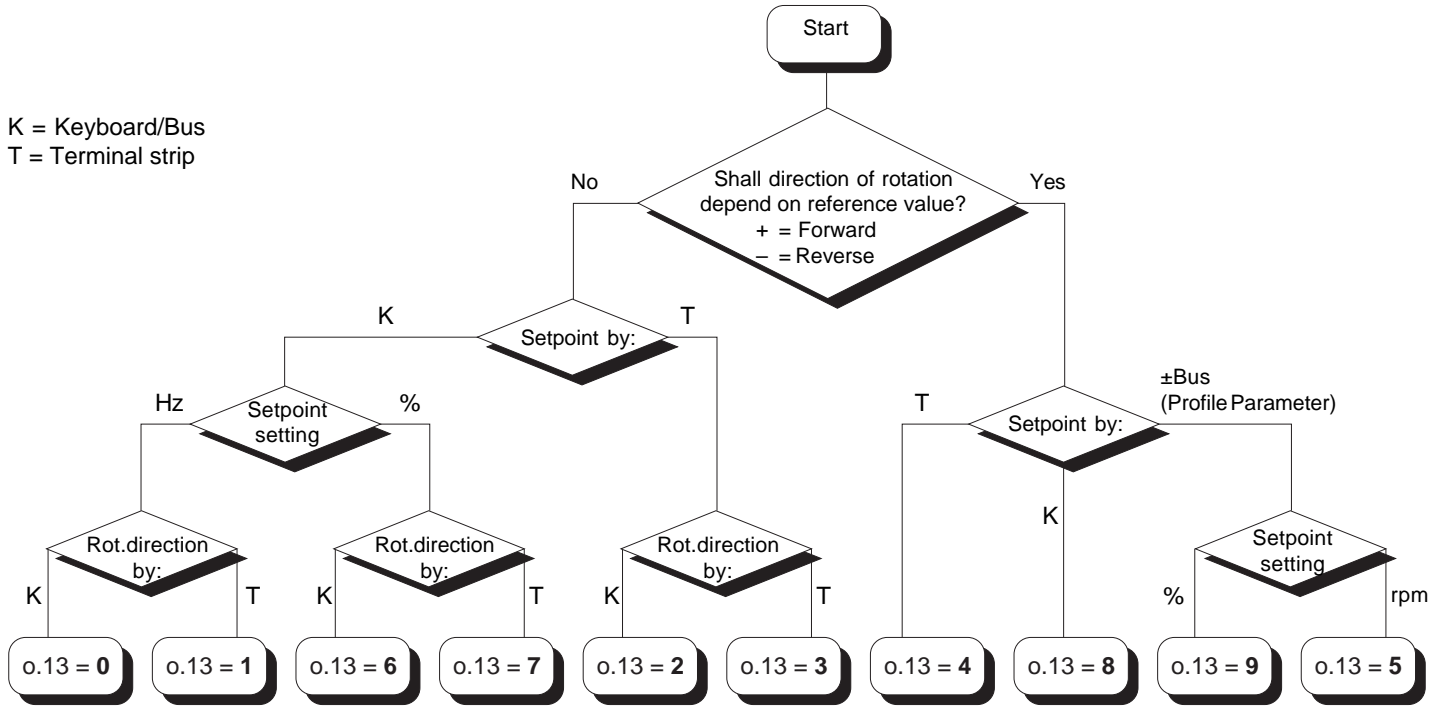

Now adjust the determined value as follows:

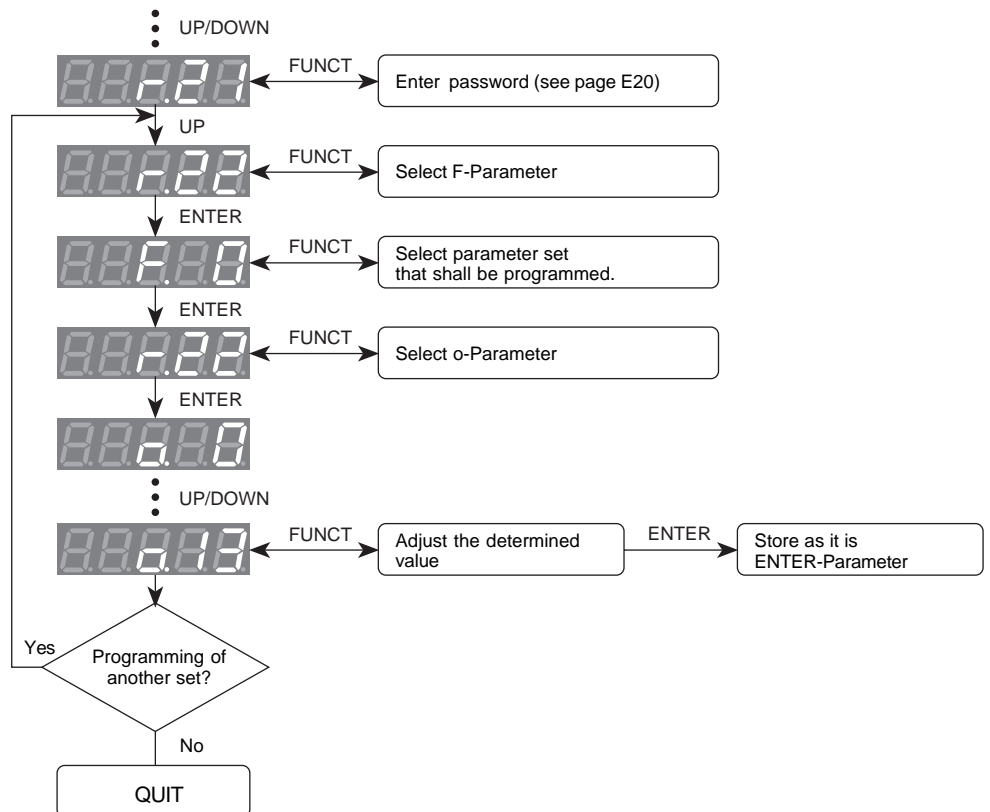

## Reference setting (digital)



With this parameter a digital reference value can be preset. For that program parameter o.13 with "0" or "1" otherwise the input has no effect. The reference value changes steadily according to the input and is stored non-volatile. As standard setting the reference value is preset in Hz, but it can also be adjusted in user definitions (see Special Settings Scaling of Display).

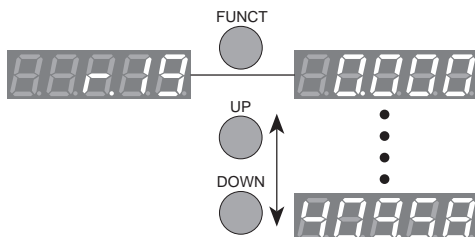

Setting range: 0...409.58 Hz  
Resolution: 0.0125 Hz

## Rotation setting (digital)



This parameter specifies the direction of rotation when o.13 is programmed with "0", "2" or "6" (rotation direction by keyboard/bus). If the value is changed the display shows a point in the last digit which indicates that the value is not yet active. By pressing ENTER the direction of rotation is accepted and the point disappears.

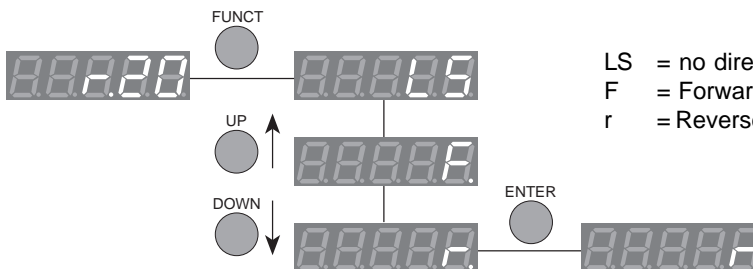

LS = no direction of rotation  
F = Forward  
r = Reverse

## Select parameter set



If parameter o.18 is adjusted to *parameter set selection by keyboard* (o.18 = 1) the parameter sets can be activated with r.23 (keyboard).  
If parameter o.18 is adjusted to *parameter set selection by bus* (o.18 = 2) the parameter sets can be activated with r.23 (bus).



Note !

*Independent of the active set (r.23) all indicated parameters refer to the parameter set adjusted in F.0 (or F.6 for bus operation).*

Exception:

*If F.0 (F.6) is set to A all parameter values refer to the active set that is displayed in r.23. Then they cannot be changed.*

REFERENCE LIMITS

Independent of the mode of reference setting an upper and lower reference limit can be defined for each direction of rotation. As standard setting the limits are preset in frequencies, but with corresponding programming other definitions can be adjusted (see Special Settings *Scaling of Display*).

	Rotation Direction	
	Forward	Reverse
min	Reference minimum A 	Reference minimum B 
max	Reference maximumA 	Reference maximum B 

Setting range

Parameter	Range	Resolution	Standard
o.1/o.3	0...o.2/o.4	0.0125 Hz	0
o.2/o.4	o.1/o.3...409.58 Hz	0.0125 Hz	70 Hz

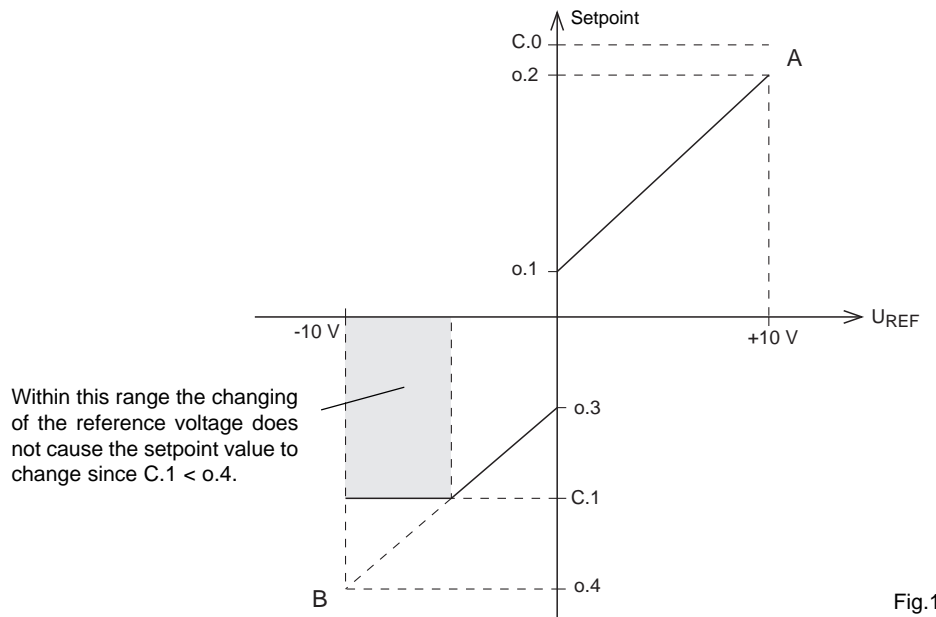

Fig.1

Limit of maximum reference



With the parameters C.0 and C.1 the limits of maximum references are adjusted. Independent of reference minimum/maximum the values can be defined for the entire range. As shown in Fig. 1 o.1...o.4 serve to calculate the analog setpoint value. For example, when adjusting C.1 < o.4 an increase of the reference voltage will have no effect as soon as C.1 is attained. Changing of adjustment see Special Settings Reference Value and Direction of Rotation.

## RAMP SETTING

8 available parameters allow the individual ramp setting. Two parameters each form  $\Delta f/\Delta t$ .

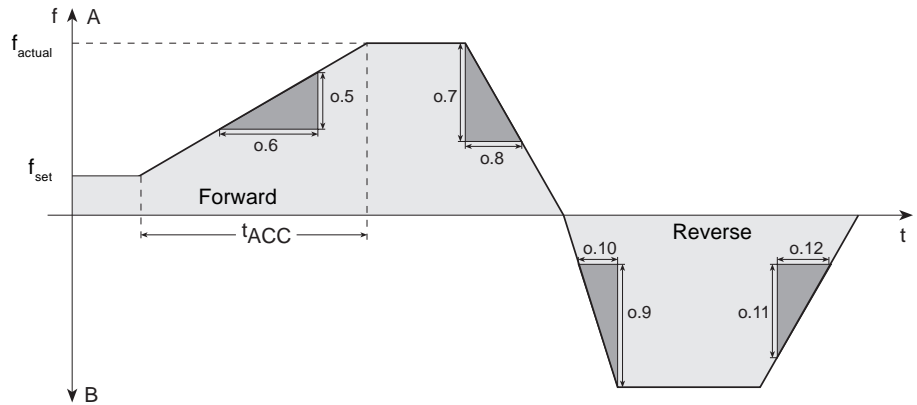

Forward accelerating	o.5	Acceleration speed A
	o.6	Acceleration time A
Forward decelerating	o.7	Deceleration speed A
	o.8	Deceleration time A
Reverse accelerating	o.9	Acceleration speed B
	o.10	Acceleration time B
Reverse decelerating	o.11	Deceleration speed B
	o.12	Deceleration time B

## Setting range

Parameter	Range	Resolution	Standard
o.5/o.7/o.9/o.11 <sup>1)</sup>	2...409.58 Hz	0.0125 Hz	70 Hz
o.6/o.8/o.10/o.12	0.05...999.50 s	0.05 s	10.00 s

<sup>1)</sup> parameter dependent on user-definition see page E97

## Calculation

Forward accelerating    o.5 = 70 Hz    i.e. the inverter accelerates  
                                   o.6 = 10 s        by 70 Hz per 10 s.

A frequency shall be driven from 21 Hz to 70 Hz.

$$t_{ACC} = \frac{f_{set} - f_{actual}}{0.5} \cdot 0.6 = \frac{70 \text{ Hz} - 21 \text{ Hz}}{70 \text{ Hz}} \cdot 10 \text{ s} = 7 \text{ s}$$

## S-CURVES

For some applications it is of advantage when the drive operates jerk-free (e.g. conveyor belt). This function is achieved by balancing the acceleration or deceleration ramps. In principle S-curves are then driven for:

- Setpoint step-changes
- Switching of rotation direction
- Reversing

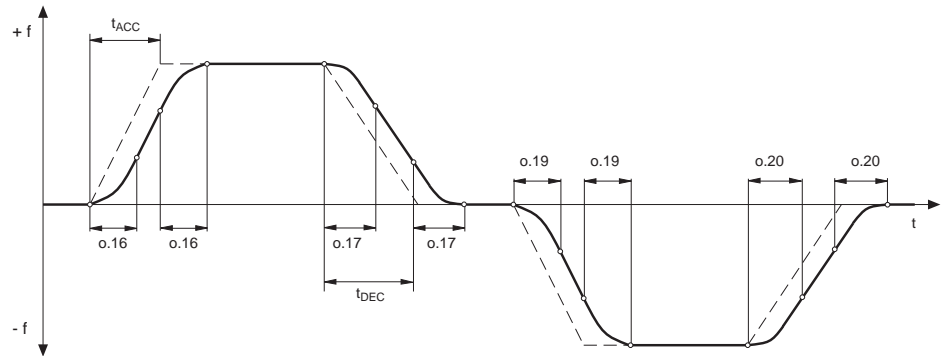

## Setting range

Parameter	Range	Resolution	Standard
o.16/o.17/o.19/o.20	0; 0.05...3.0 (0 = off)	0.05 s	off

## Mode of functioning

Forward accelerating:

At the beginning and the end of the acceleration ramp a parabolic curve is driven with the time of o.16. Thus the adjusted ramp time ( $t_{ACC}$ ) is increased by o.16. This also applies to o.17, o.19 and o.20.



*In order to drive specified ramp times the following conditions must be met*

$$o.16 (o.19) - t_{ACC}$$

$$\text{and } o.17 (o.20) - t_{DEC}$$

## BOOST/DELTA-BOOST



In the lower speed range a large portion of the motor voltage dissipates at the stator winding as with decreasing frequency the reactance of the main inductivity of the motor decreases. To keep the breakaway torque of the motor nearly constant over the entire speed range the voltage drop must be compensated. This compensation is achieved with the boost.

Operating a motor in continuous operation at small speed with too high voltage can lead to the overheating of the motor.

If a high breakaway torque is needed due to high static friction the Delta-Boost should be used as it acts time-limited.

### Boost



Adjustment of voltage rise for lower speed range.

Range	Resolution	Standard
0...25.5 %	0.1 %	2.0 %

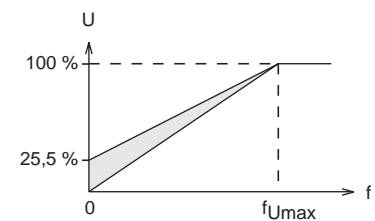

- Optimization:
- Determine inverter load ( $r.7$ ) in no-load operation at corner frequency (for standard motor = 50 Hz).
  - Adjust the boost so that the same load is achieved at small frequencies (ca. 10 Hz).
  - To achieve an optimal adjustment of the boost even at fluctuating load of the motor the function Auto-Boost (see page E94/E95) should be activated.

### Delta-Boost



The Delta-Boost is a time-limited boost that is used to overcome large breakaway torques. Delta-Boost acts adding to the boost (o.0). If the sum exceeds 25.5 % the value for the Delta-Boost will be limited internally.

Range	Resolution	Standard
0...25.5 %	0.1 %	0 %

### Delta-Boost/time



Adjustment of the time in which Delta-Boost is effective.

Range	Resolution	Standard
0.05...25.50 s	0.05s	0.1 s

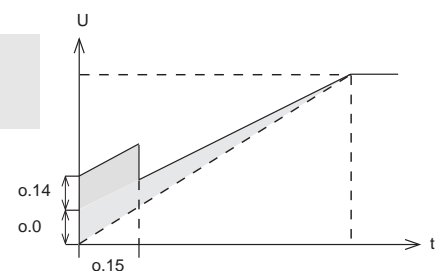

Connection of Control Board  
Page E4 - E14

Operation of the Unit  
Page E15 - E22

Starting  
Page E23 - E30

✓ Parameter  
Page E31 - E68

Special Settings  
Page E69 - E112

Annex  
Page E113 - E122

Index  
Page E123 - E124



## Parameter survey

- r(un) - Parameter
- o(peration) - Parameter
- P(rotection) - Parameter
- H(andle) - Parameter
- L(evel) - Parameter
- d(rive) - Parameter
- C(ustomer) - Parameter
- c(ontrol) - Parameter
- F(ree-programmable) - Parameter
- I(nformation) - Parameter
- Pr(ofile) - Parameter

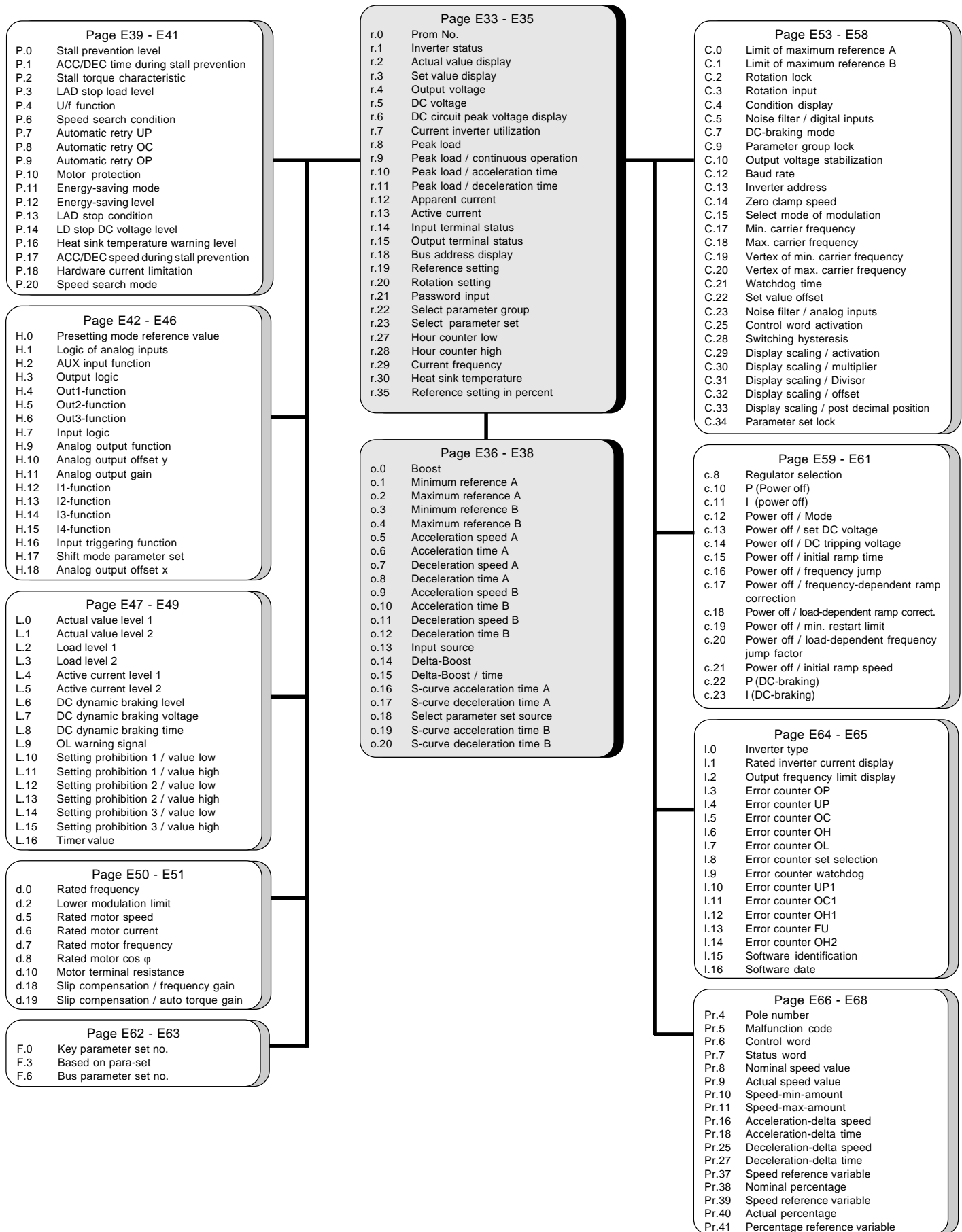



## r-PARAMETERS

indicate the operating conditions and are used to enter setpoint value, direction of rotation and password.

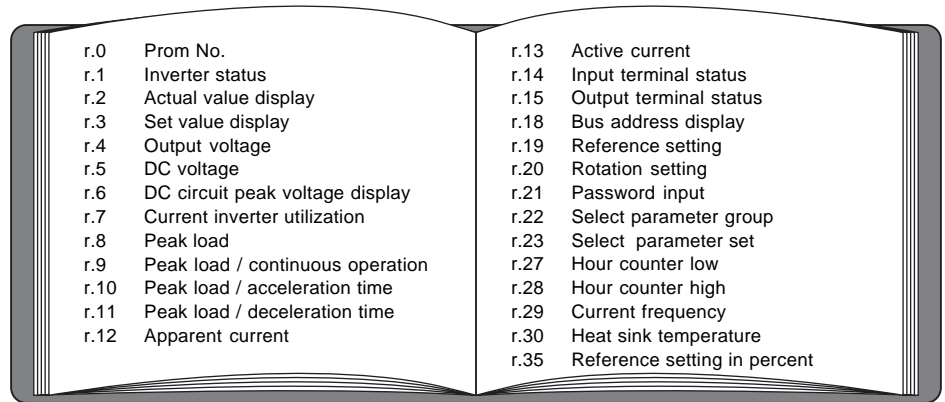

r.0	Prom No.	r.13	Active current
r.1	Inverter status	r.14	Input terminal status
r.2	Actual value display	r.15	Output terminal status
r.3	Set value display	r.18	Bus address display
r.4	Output voltage	r.19	Reference setting
r.5	DC voltage	r.20	Rotation setting
r.6	DC circuit peak voltage display	r.21	Password input
r.7	Current inverter utilization	r.22	Select parameter group
r.8	Peak load	r.23	Select parameter set
r.9	Peak load / continuous operation	r.27	Hour counter low
r.10	Peak load / acceleration time	r.28	Hour counter high
r.11	Peak load / deceleration time	r.29	Current frequency
r.12	Apparent current	r.30	Heat sink temperature
		r.35	Reference setting in percent

Prom No.

□ □ r. 0

Indication of the number of software version.

Inverter Status

□ □ r. 1

Indication of inverter status messages.

Actual value display

□ □ r. 2

Indication of actual output frequency in Hz (dependent on user-definition).

Set value display

□ □ r. 3

Indication of setpoint frequency, which is preset by terminal strip, keyboard or bus (dependent on user-definition).

Output voltage

□ □ r. 4

Indication of current output voltage in volt.

DC voltage

□ □ r. 5

Indication of current intermediate circuit voltage in volt.

DC circuit peak voltage display

□ □ r. 6

Indication of maximum intermediate circuit voltage measured during operation. Press the ENTER key or write on the parameter by bus to reset the value.

Current inverter utilization

□ □ r. 7

Indication of current inverter utilization in percent. The value can be 0...200 %.

Peak load

□ □ r. 8

Indication of maximum load in percent measured during operation. Press the ENTER key or write on the parameter by bus to reset the value.

Peak load / continuous operation

□ □ r. 9

Indication of maximum load in percent measured during constant speed. Press the ENTER key or write on the parameter by bus to reset the value.

Peak load / acceleration time

□ □ r. 10

Indication of maximum load recorded during acceleration. Press the ENTER key or write on the parameter by bus to reset the value.

Peak load / deceleration time

□ □ r. 11

Indication of maximum load in percent recorded during deceleration. Press the ENTER key or write on the parameter by bus to reset the value.

Apparent current

□ □ r. 12

Indication of the actual apparent motor current in ampere.

Active current

□ □ r. 13

Indication of the actual active current in ampere.

Positive values: motoric operation

Negative values: generatoric operation



Depending on the motor being used the actual active current display must be calibrated before using it with d.10 (motor terminal resistance).

Input terminal status

□ □ r. 14

Terminal	Input	Value	Example
X1.5	I1	$2^0 = 1$	-> 1
X1.6	I2	$2^1 = 2$	
X1.7	I3	$2^2 = 4$	
X1.10	F	$2^3 = 8$	-> 8
X1.11	R	$2^4 = 16$	
X1.19	ST	$2^5 = 32$	-> 32
X1.20	RST	$2^6 = 64$	
X1.27	I4	$2^7 = 128$	
Display			= 41

In the example outputs I1, F and ST are triggered.

Output terminal status

□ □ r. 15

Terminal	Output	Value	Example
X1.12/X1.21...23	OUT1	$2^0 = 1$	-> 1
X1.24/X1.1...3	OUT2	$2^1 = 2$	
X1.25	OUT3	$2^2 = 4$	-> 4
Display			= 5

In the example outputs Out1 and Out3 are set.

Bus address display

□ □ r. 18

Indication of bus address defined with parameter C.13. Under this address the inverter can be addressed, for example by COMBIVIS.

## Reference Setting

 (o.13 = 0 or 1)

Setpoint value setting by keyboard (dependent on user-definition).

Range	0...409.58 Hz
Resolution	0.0125 Hz

## Rotation setting

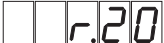
 (o.13 = 0, 2 or 6)

 Setting of rotation direction by keyboard: LS = no direction of rotation  
 F = Forward  
 r = Reverse

## Password input

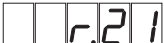

 Enter the password under this parameter before programming.  
 (Password entry see page E20, Passwords see page E119).

 Possible messages:
 

- nPA = no valid password yet
- PA.X = Password level X enabled (X = 1...3)
- FAu = Wrong password input
- noF = Function aborted (after 3 wrong inputs)

## Select parameter group



Defines the parameter group jumped into by pressing ENTER.

## Select parameter set



If parameter o.18 is adjusted to parameter set selection by keyboard (o.18 = 1), the parameter sets can be activated with r.23 (keyboard).

If o.18 • 1 then r.23 serves to display the parameter set activated by terminal strip or bus.

## Hour counter low

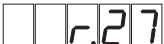

Parameter r.27 and r.28 indicate the operating hours.

r.27 → indicated value in hours

## Hour counter high



r.28 → indicated value • 1000 hours

## Current frequency



Independent of the defined specification this parameter indicates the current output frequency.

## Heat sink temperature



Indication of heat sink temperature in °C. Only inverters of the F1-series display this measured value. Inverters of the 56-series show off.

## Reference setting in percent

 (o.13 = 6, 7 or 8)

An analog setpoint value setting is simulated with r.35. The presetting is done with a percentage in reference to the setpoint value limits defined with o.1, o.2 and o.3, o.4. Is o.13 = 6 or 7 the sign will be ignored. Is o.13 = 8 then the sign determines the direction of rotation.

 0% always correspond to the reference minimum A (o.1).

Range	Resolution	Standard
-100.0 %...100.0 %	0.1 %	0.0 %

## o-PARAMETERS

serve to adapt the frequency inverter to the respective application.

o.0	Boost	o.13	Input source
o.1	Minimum reference A	o.14	Delta-Boost
o.2	Maximum reference A	o.15	Delta-Boost / time
o.3	Minimum reference B	o.16	S-curve acceleration time A
o.4	Maximum reference B	o.17	S-curve deceleration time A
o.5	Acceleration speed A	o.18	Select parameter set source
o.6	Acceleration time A	o.19	S-curve acceleration time B
o.7	Deceleration speed A	o.20	S-curve deceleration time B
o.8	Deceleration time A		
o.9	Acceleration speed B		
o.10	Acceleration time B		
o.11	Deceleration speed B		
o.12	Deceleration time B		

### Boost

□ □ 0. □ 0

Adjustment of the voltage rise in the lower speed range.

Range	Resolution	Standard
0...25.5 %	0.1 %	2.0 %

### Minimum reference A

□ □ 0. □ 1

Minimum setpoint input for rotational direction forward (dependent on user-definition).

Range	Resolution	Standard
0...409.58 Hz (max. to o.2)	0.0125 Hz	0 Hz

### Maximum reference A

□ □ 0. □ 2

Maximum setpoint input for rotational direction forward (dependent on user-definition).

Range	Resolution	Standard
0...409.58 Hz (min. to o.1)	0.0125 Hz	70 Hz

### Minimum reference B

□ □ 0. □ 3

Minimum setpoint input for rotational direction reverse (dependent on user-definition).

Range	Resolution	Standard
0...409.58 Hz (max. to o.4)	0.0125 Hz	0 Hz

### Maximum reference B

□ □ 0. □ 4

Maximum setpoint input for rotational direction reverse (dependent on user-definition).

Range	Resolution	Standard
0...409.58 Hz (min. to o.3)	0.0125 Hz	70 Hz

### Acceleration speed A

□ □ 0. □ 5

Presetting of frequency change for  $\Delta f/\Delta t$  forward acceleration (dependent on user-definition) (Fig. 1).

Range	Resolution	Standard
2...409.58 Hz	0.0125 Hz	70 Hz

### Acceleration time A

□ □ 0. □ 6

Presetting of time change for  $\Delta f/\Delta t$  forward acceleration (Fig. 1).

Range	Resolution	Standard
0.05...999.50 s	0.05 s	10 s

Deceleration speed A

□ □ 0. 7

Like o.5, but for forward deceleration.

Deceleration time A

□ □ 0. 8

Like o.6, but for forward deceleration.

Acceleration speed B

□ □ 0. 9

Like o.5, but for reverse acceleration.

Acceleration time B

□ □ 0. 10

Like o.6, but for reverse acceleration.

Deceleration speed B

□ □ 0. 11

Like o.5, but for reverse deceleration.

Deceleration time B

□ □ 0. 12

Like o.6, but for reverse deceleration.

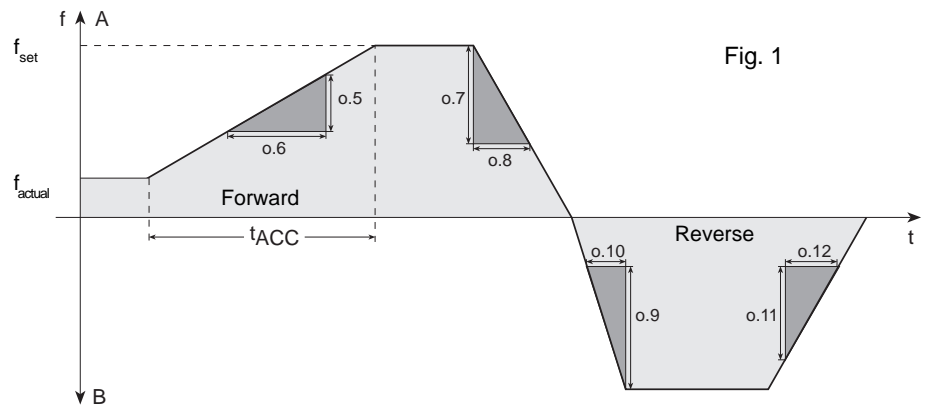

Input source

□ □ 0. 13

This parameter defines, where to query for setpoint value and direction of rotation.

	Setpoint value	Direction of rotation
0	Keyboard/Bus (r.19)	Keyboard/Bus (r.20)
1	Keyboard/Bus (r.19)	Terminal strip
2	Terminal strip	Keyboard/Bus (r.20)
3	Terminal strip	Terminal strip (Standard)
4	Terminal strip +/-	dependent on setpoint value
5	Profile Parameter (Pr.8)	dependent on setpoint value
6	Keyboard/Bus % (r.35)	Keyboard/Bus (r.20)
7	Keyboard/Bus % (r.35)	Terminal strip
8	Keyboard/Bus % (r.35)	dependent on setpoint value
9	Profile Parameter % (r.38)	dependent on setpoint value

Delta-Boost

□□ **o.14**

The Delta-Boost, which is a boost limited in time, is used to overcome large breakaway torques. The effect of the Delta-Boost is added to the Boost (o.0). If the sum exceeds 25.5 %, the value for the Delta-Boost is limited internally.

Range	Resolution	Standard
0...25.5 %	0.1 %	0 %

Delta-Boost / time

□□ **o.15**

Adjustment of the time in which Delta-Boost is effective.

Range	Resolution	Standard
0.05...25.50 s	0.05 s	0.1 s

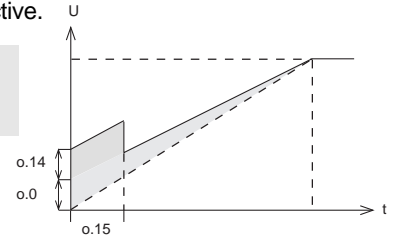

S-curve acceleration time A

□□ **o.16**

With this parameter the balancing of the acceleration ramp forward is adjusted. The balancing provides a smooth transition between the ramp and operation at constant speed and a jerk-free acceleration.

Range	Resolution	Standard
0 (off), 0.05...3 s	0.05 s	0 (off)

S-curve deceleration time A

□□ **o.17**

Like o.16, but for deceleration ramp forward.

Select parameter set source

□□ **o.18**

With this parameter it is defined, how the parameter set selection is done.

Value	Select parameter set source
0	Set selection deactivated
1	Keyboard (set selection by r.23)
2	Bus (set selection by r.23)
3 *	Terminal strip coded without strobe
4	Terminal strip coded with strobe
5	Terminal strip uncoded without strobe
6	Terminal strip uncoded with strobe
	* Factory setting

S-curve acceleration time B

□□ **o.19**

Like o.16, but for acceleration ramp reverse.

S-curve deceleration time B

□□ **o.20**

Like o.16, but for deceleration ramp reverse.

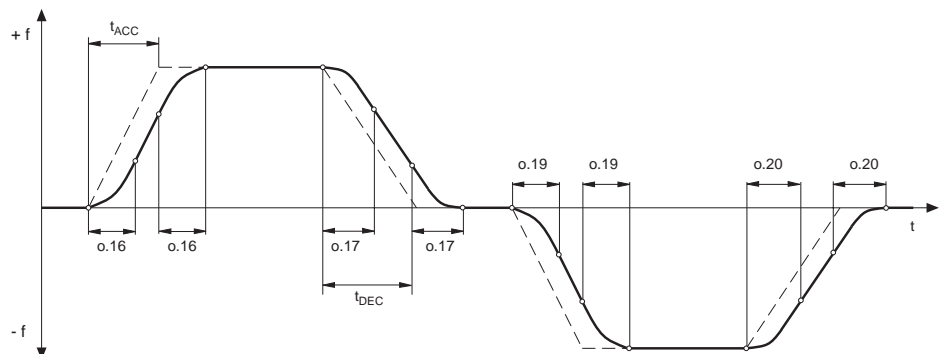

**P (PROTECTION)-PARAMETERS**

protect the inverter against overload and interferences.

P.0	Stall prevention level	P.14	LD stop DC voltage level
P.1	ACC/DEC time during stall prevention	P.16	Heat sink temperature warning level
P.2	Stall torque characteristic	P.17	ACC/DEC speed during stall prevention
P.3	LAD stop load level	P.18	Hardware current limitation
P.4	U/f function	P.20	Speed search mode
P.6	Speed search condition		
P.7	Automatic retry UP		
P.8	Automatic retry OC		
P.9	Automatic retry OP		
P.10	Motor protection		
P.11	Energy-saving mode		
P.12	Energy-saving level		
P.13	LAD stop condition		

Stall prevention level

Stall function becomes active at the set current level. The stall function protects the inverter against switch off by overcurrent during constant speed (see Special Settings Current Limit ).

Range	Resolution	Standard
10...150 %, off	1 %	150 %

ACC/DEC time during stall prevention

The time and P.17 form  $\Delta f/\Delta t$ . When the current limit P.0 is exceeded the frequency is increased/decreased with  $\Delta f/\Delta t$ .

Range	Resolution	Standard
0.05...999.50 s	0.05 s	1 s

Stall torque characteristic

Defines the behaviour of the inverter when the current limit is exceeded. P.2 must be adjusted to the torque/speed characteristic of the machine.

Value	Frequency	up to
0 *	is decreased	min. o.1/o.3
1	is increased	max. o.2/o.4
2	is decreased	min. d.2
3	is increased	max. C.0/C.1
* Standard value		

LAD stop load level

With this parameter the current level is defined at which the ramp stop becomes active (activation → P.13).

Range	Resolution	Standard
10...199 %	1 %	150 %

U/f function

Voltage/frequency behaviour at the start, reversing and after low speed, if d.2 • 0.

- off = Voltage according to V/Hz characteristic (Standard)
- on = Voltage-acceleration at the current limit (smooth start up)

## Speed search condition

□ □ P. 6

Permits the connection of the inverter to a coasting motor.

Value	Speed search
0	Function off (Standard)
1	Triggered through control release
2	Triggered through cold start
4	Triggered through reset
8	Triggered through automatic retry

In case of several conditions the values are to be added up.

## Automatic retry UP

□ □ P. 7

When error UP/UP1 occurs after a short-time power failure, the error is automatically reset if the function is activated. The number of resets can be limited.

Value	Meaning
0	Function deactivated (Standard)
1...10	Number of resets within 10 min
11	Function generally on

## Automatic retry OC

□ □ P. 8

The number of automatic resets within 10 min. after error OC/OC1 is defined with this parameter. The hold-off interval before restart is 15 sec.

Value	Meaning
0	Function off (Standard)
1...5	Number of resets within 10 min

## Automatic retry OP

□ □ P. 9

The number of automatic resets within 10 min. after error OP is defined with this parameter. The hold-off interval is 20 sec.

Value	Meaning
0	Function off (Standard)
1...10	Number of resets within 10 min

## Motor protection

□ □ P. 10

Activation of electronic protective motor relay according to VDE 0660.

Is P.10 = 1 or 2 (only warning) the message can set an output (see H.4/H.5/H.6).

Is P.10 = 3 or 4, error OH2 is indicated and the power modules are disconnected, when the protective function responds. The fault relay picks up.

## Attention!

An unobjectionable function requires the correct setting of the rated motor current (d.6).

Value	Meaning
0	Protective motor relay deactivated (Standard)
1	Protective motor relay activated, with separate ventilation, only warning
2	Protective motor relay activated, without separate ventilation, only warning
3	Protective motor relay activated, with separate ventilation, switch-off
4	Protective motor relay activated, without separate ventilation, switch-off

## Energy-saving mode

□ □ P. 11

With this parameter it is defined, how the energy-saving function is activated.

Value	Meaning
0	deactivated
1	generally on
2	at $f_{actual} = f_{set}$
3	by programmable input (→ H.12...H.15)
4	generally activated for rotational direction forward
5	generally on for rotational direction reverse



Energy-saving level

P.12

Value of output voltage to which decrease/increase takes place at activated function.

Range	Resolution	Standard
30...130 %	1 %	100 %

LAD stop condition

P.13

With this parameter the conditions are defined that activate the ramp-stop function.

- LD(I) Ramp stop for deceleration (current-controlled)
- LD(U<sub>zk</sub>) Ramp stop for deceleration (voltage-controlled)
- LA Ramp stop for acceleration (current-controlled)
- \*) **Standard**

Value	LD (I)	LD (U <sub>zk</sub> )	LA
0	OFF	OFF	OFF
1 *)	OFF	OFF	ON
2	OFF	ON	ON
3	ON	OFF	ON
4	ON	ON	ON
5	OFF	ON	OFF
6	ON	OFF	OFF
7	ON	ON	OFF

LD stop DC voltage level

P.14

The level of the intermediate circuit voltage is defined with this parameter. Ramp stop is activated (→ P.13) when this level is exceeded.

Range	Resolution	Standard
200...800 V	1 V	375 V (200 V class) 720 V (400 V class)

Heat sink temperature warning level

P.16

Defines a temperature value, on reaching this value an output can be set (→ H.4/H.5/H.6). Only units of the F1-series provide this function.

Range	Resolution	Standard
0...100° C	1° C	70° C

ACC/DEC speed during stall prevention

P.17

Frequency change, which forms together with P.1  $\Delta f/\Delta t$ . When the current limit is exceeded the frequency is decreased/increased (depending on standard specification).

Range	Resolution	Standard
2.0...409.58 Hz	0.0125 Hz	70 Hz

Hardware current limitation

P.18

Activation of hardware current limitation.

Range	Standard
off / on	on ( $I_{max} = 200 \% I_N$ )

The hardware current limit prevents OC errors through ramp stop as well as the reduction of output voltage.

Speed search mode

P.20

The parameter P.20 specifies the mode of speed search. Usually the higher the adjusted value the faster works the function. If an error occurs during the speed search reduce the value until a faultless function is guaranteed.

Value	Load	Voltage rise	Frequency decrease
0	Level 80 %	dU/dt = 0.03 %/ms	df/dt = 70 Hz/s (Standard)
1	Level 130 %	dU/dt = 0.03 %/ms	df/dt = 70 Hz/s
2	Level 80 %	dU/dt = 0.12 %/ms	df/dt = 280 Hz/s
3	Level 130 %	dU/dt = 0.12 %/ms	df/dt = 280 Hz/s
4	Level 80 %	dU/dt = 0.24 %/ms	df/dt = 560 Hz/s
5	Level 130 %	dU/dt = 0.24 %/ms	df/dt = 560 Hz/s



## Output logic

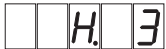

With the output logic the outputs Out1...Out3 can be inverted.

Value	Out3	Out2	Out1
0	–	–	–
1	–	–	x
2	–	x	–
3	–	x	x
4	x	–	–
5	x	–	x
6	x	x	–
7	x	x	x

x = inverted

## Out1-function



Defines the conditions for the switching of relay 1 (terminal X1.21...X1.23) and the transistor output Out1 (terminal X1.12).

(Standard: Fault signal H.4 = 0)

Value	Function
0	Fault/Run signal respond to every error
1	Fault/Run signal doesn't respond to error UP
2	Overload prewarning (also see L.9)
3	Overtemperature prewarning (also see P.16)
4	Utilization > utilization level (L.2/L.3)
5	Actual value < setpoint value
6	Actual value > setpoint value
7	Actual value = setpoint value
8	Actual value < actual value level (L.0/L.1)
9	Actual value < actual value level (L.0/L.1), but not with "Speed Search"
10	Actual value > actual value level (L.0/L.1)
11	Actual value = actual value level (L.0/L.1)
12	Setpoint value < actual value level (L.0/L.1)
13	Setpoint value > actual value level (L.0/L.1)
14	Output becomes active, if time of timer L.16/L.17 has expired
15	Active current > active current level (L.4/L.5)
16	Protective motor relay-prewarning (also see P.10, d.6)
17	Apparent current > utilization level (L.2/L.3) and actual value = setpoint value
18	Output active, when frequency = 0 and no DC-Braking
19	Output active when "Power off" active
20	Actual value > actual value level (L.0/L.1) and actual rotation = set rotation



*Use value "15" only when r.13 has been calibrated with d.10.*

## Out2-function



Defines the conditions for the switching of relay 2 (terminal X1.1...X1.3) and the transistor output Out2 (terminal X1.24).

(Presetting: Frequency-dependent switch H.5 = 7)

Value table see H.4.



*Use value "15" only when r.13 has been calibrated with d.10.*

## Out3-function



Defines the conditions for the switching of transistor output Out3 (terminal X1.25).

(Presetting: Overload prewarning H.6 = 2)

Value table see H.4



*Use value "15" only when r.13 has been calibrated with d.10.*



I1-function

H.12

Terminal X1.5

I2-function

H.13

Terminal X1.6

I3-function

H.14

Terminal X1.7

I4-function

H.15

Terminal X1.27

When inputs I1...I4 are activated they can perform one of the following functions:

Value	Function	Presetting
0	Input without function	H.12 = 1
1	Input serves for parameter set selection	H.13 = 1
2	Reset for all inputs that are edge-triggered and that serve for parameter set selection (return to set 0)	H.14 = 3 H.15 = 5
3	Input activates DC-Braking	
4	Input activates energy-saving function	
5	Input activates ramp stop	
6	Input activates external error	
7	Input serves as strobe signal for all inputs for parameter set selection	

Input triggering function

H.16

Depending on H.16 the inputs I1...I4 can be triggered by static signals or edge-triggered.

Value	I4	I3	I2	I1	Value	I4	I3	I2	I1
0 *	-	-	-	-	8	o	-	-	-
1	-	-	-	o	9	o	-	-	o
2	-	-	o	-	10	o	-	o	-
3	-	-	o	o	11	o	-	o	o
4	-	o	-	-	12	o	o	-	-
5	-	o	-	o	13	o	o	-	o
6	-	o	o	-	14	o	o	o	-
7	-	o	o	o	15	o	o	o	o

\* = Standard  
 - = Input static  
 o = Input edge-triggered



*If an input is programmed as Reset (H.12...H.15), the input shall not be edge-triggered.*

Shift mode parameter set

    H.17

Defines the resetting of edge-triggered inputs.

Value    Meaning

0	Edge-triggered inputs are buffered and are set with the 1st edge and reset with 2nd edge.
1	No input buffer; edge cancels the active set and switches to the selected set (Standard).

Example H.17 = 0

Basic principle:

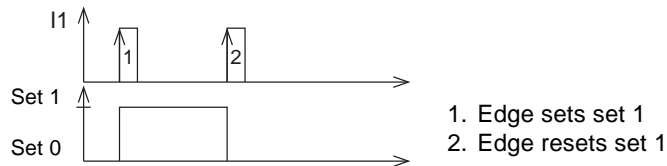

1. Edge sets set 1
2. Edge resets set 1

Principle of input buffer:

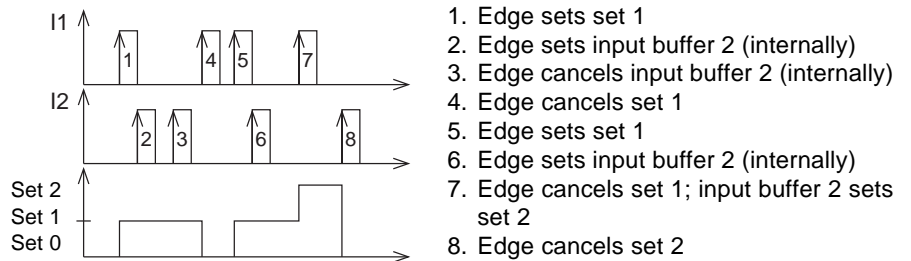

1. Edge sets set 1
2. Edge sets input buffer 2 (internally)
3. Edge cancels input buffer 2 (internally)
4. Edge cancels set 1
5. Edge sets set 1
6. Edge sets input buffer 2 (internally)
7. Edge cancels set 1; input buffer 2 sets set 2
8. Edge cancels set 2

Priority-dependending  
I1 > I2 > I3 > I4

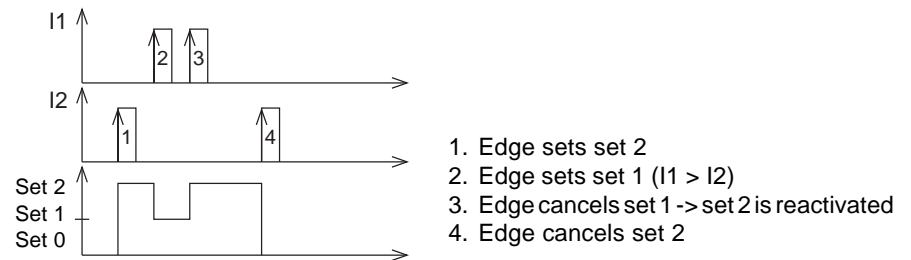

1. Edge sets set 2
2. Edge sets set 1 (I1 > I2)
3. Edge cancels set 1 -> set 2 is reactivated
4. Edge cancels set 2

Example H.17 = 1

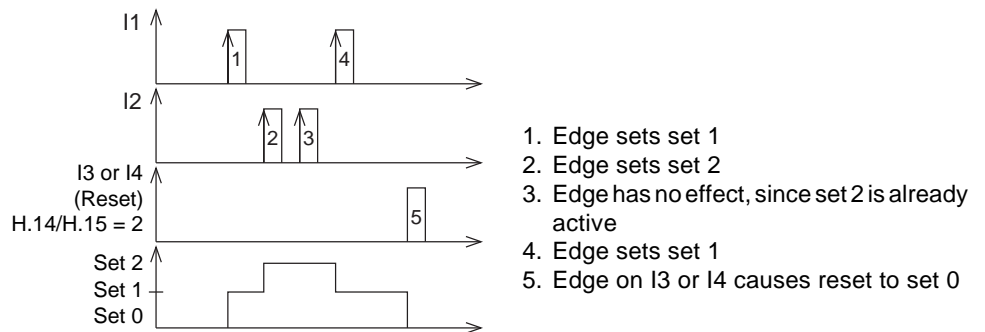

1. Edge sets set 1
2. Edge sets set 2
3. Edge has no effect, since set 2 is already active
4. Edge sets set 1
5. Edge on I3 or I4 causes reset to set 0

The reset-input must be programmed as static input.

Analog output offset x

    H.18

Allows the shifting of the characteristic on the x-axis (also refer to H.9...H.11).

Range	Resolution	Standard
0...100 %	1 %	0 %

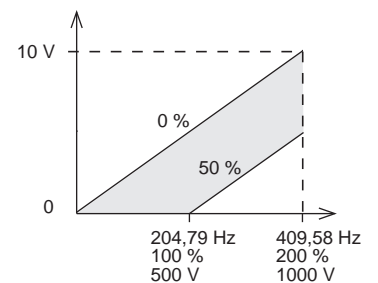

With the L (LEVEL)-PARAMETERS the switching level is defined. These levels are used to switch the outputs, to skip setpoint values and to adjust DC-Braking.

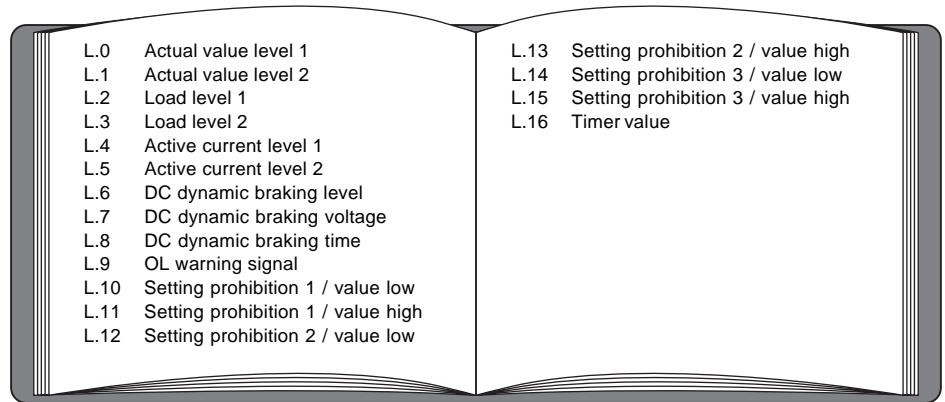

L.0	Actual value level 1	L.13	Setting prohibition 2 / value high
L.1	Actual value level 2	L.14	Setting prohibition 3 / value low
L.2	Load level 1	L.15	Setting prohibition 3 / value high
L.3	Load level 2	L.16	Timer value
L.4	Active current level 1		
L.5	Active current level 2		
L.6	DC dynamic braking level		
L.7	DC dynamic braking voltage		
L.8	DC dynamic braking time		
L.9	OL warning signal		
L.10	Setting prohibition 1 / value low		
L.11	Setting prohibition 1 / value high		
L.12	Setting prohibition 2 / value low		

Actual value level 1

□ □ L . 0

Definition of actual value level that switches output Out1 (terminal X1.21...X1.23 and X1.12) in dependence on H.4 (dependent on user-definition).

Range	Resolution	Standard
0...409.58 Hz	0.0125 Hz	0 Hz

Actual value level 2

□ □ L . 1

Definition of actual value level that switches the outputs Out2 (terminal X1.1...X1.3 and X1.24) and Out3 (terminal X1.25) in dependence on H.5/H.6 (dependent on user-definition).

Range	Resolution	Standard
0...409.58 Hz	0.0125 Hz	4 Hz

Load level 1

□ □ L . 2

Definition of load level that switches output Out1 in dependence on H.4.

Range	Resolution	Standard
0...200 %	1 %	50 %

Load level 2

□ □ L . 3

Definition of load level that switches the outputs Out2/Out3 in dependence on H.5/H.6.

Range	Resolution	Standard
0...200 %	1 %	100 %

Active current level 1

□ □ L . 4

Definition of active current level that switches output Out1 in dependence on H.4.

Range	Resolution	Standard
0...999.9 A	0.1 A	0 A

Active current level 2

□ □ L . 5

Definition of active current level that switches the outputs Out2/Out3 in dependence on H.5/H.6.

Range	Resolution	Standard
0...999.9 A	0.1 A	0 A

DC dynamic braking level

□ □ L . 6

Definition of actual value level that activates DC-Braking in dependence on C.7 (dependent on user-definition).

Range	Resolution	Standard
0...409.58 Hz	0.0125 Hz	0 Hz

DC dynamic braking voltage

□ □ L . 7

Defines the upper voltage limit for the braking current controller (c.22/c.23). The parameter is set to an average value and can be optimized to correspond to the application (see Special Settings *DC-Braking*).

Range	Resolution	Standard
0...25.5 %	0.1 %	10 %

DC dynamic braking time

□ □ L . 8

Defines the duration of DC-Braking. According to the mode (C.7) the time depends on the actual frequency, i.e. the adjusted braking time refers to the maximum reference A (o.2) and is reduced in proportion to the actual frequency. Is maximum reference B (o.4) > maximum reference A (o.2), the braking time may increase in correspondence to the actual frequency.

Range	Resolution	Standard
0...100 s	0.05 s	0.1 s

Example:

$$\begin{aligned}
 \text{Actual braking time} &= \frac{L.8 \cdot f_{\text{actual}}}{0.2} \\
 &= \frac{10 \text{ s} \cdot 35 \text{ Hz}}{70 \text{ Hz}} \\
 &= 5 \text{ s}
 \end{aligned}$$

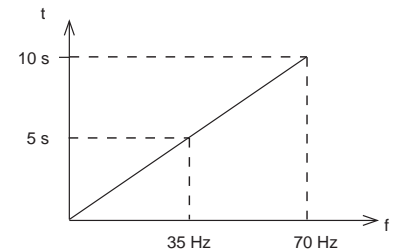

OL warning signal

□ □ L . 9

Can set an output after expiration of the adjusted time (H.4/H.5/H.6 = 2). The value of L.9 refers to the OL-release time (refer to power circuit).

Example: Release time 30 s  
L.9 = 75 %

$$\text{Time, after which a warning is given} = \frac{30 \text{ s} \cdot 75 \%}{100 \%} = 22.5 \text{ s}$$

Range	Resolution	Standard
0...100 %	1 %	66 %



Setting prohibition 1 / value low

L.10

Setting prohibition 1 / value high

L.11

Setting prohibition 2 / value low

L.12

Setting prohibition 2 / value high

L.13

Setting prohibition 3 / value low

L.14

Setting prohibition 3 / value high

L.15

With parameters L.10...L.15 up to 3 frequency ranges can be locked for operation with constant speed where critical resonances can occur in the drive. Two values each exclude one range.

For the sequence of adjustment the following condition must be observed:

L15 • L.14 • L.13 • L.12 • L.11 • L.10

Based on the basic setting (L.10...L.15 = 0), always start with L.15.

Range	Resolution	Standard	Particularity
0...409.58 Hz	0.0125 Hz	0 Hz	dependent on user-definition

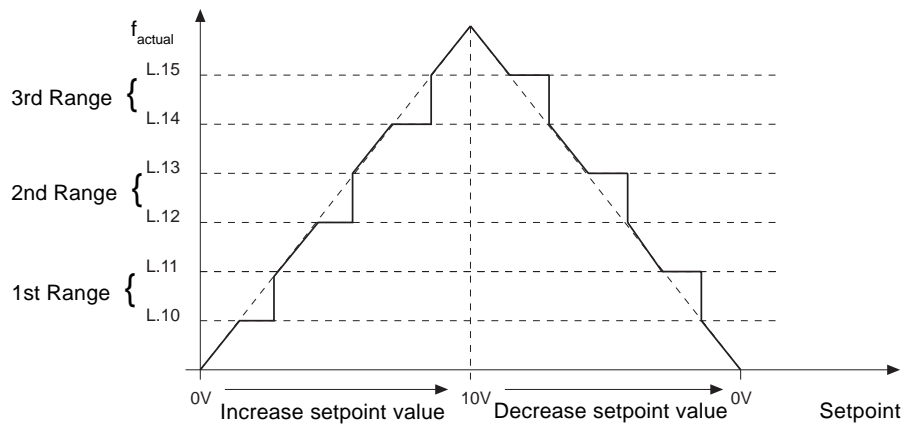

No frequencies are skipped for acceleration and deceleration.

Timer value

L.16

After expiration of the time adjusted here an output can be set (H.4/H.5/H.6 = 14). The timer starts, if a parameter set has been activated in which the timer has been programmed. However, if the inverter is in the state nOP or LS the timer does not start unless these states are left first.

Range	Resolution	Standard
0.00...327.66 s	0.01 s	0 s

Timer Function

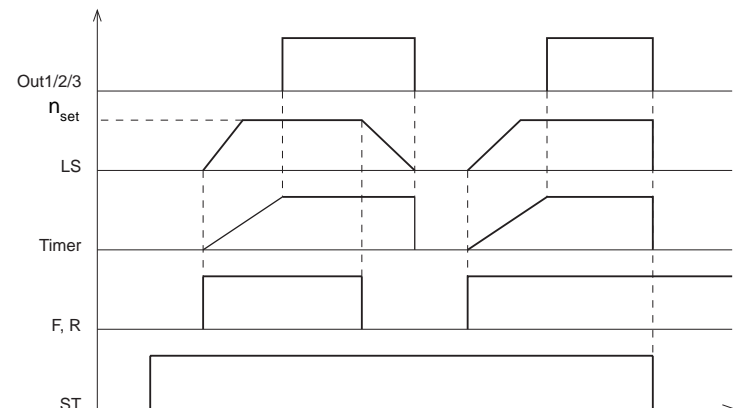

**d (DRIVE)-PARAMETERS**  
define motor-specific data.

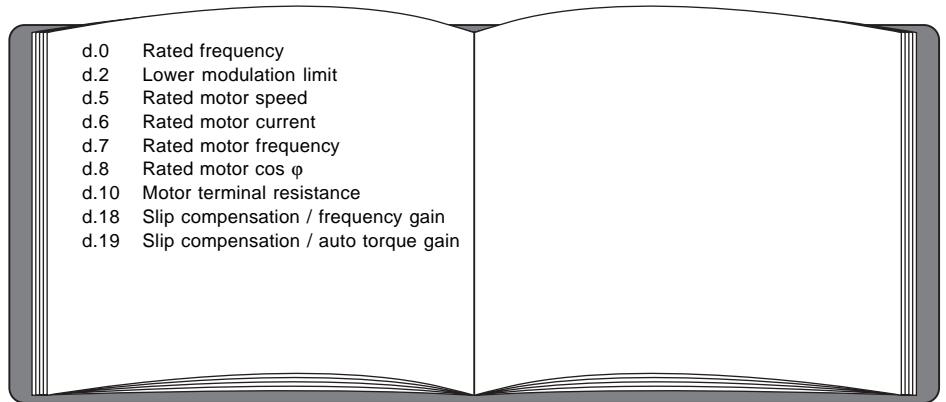

Rated frequency

□ □ d . 0

Definition of the rated frequency  $f_{Umax}$  where the inverter reaches its maximum output voltage.

Range	Resolution	Standard
20.0...409.5 Hz	0.1 Hz	50 Hz

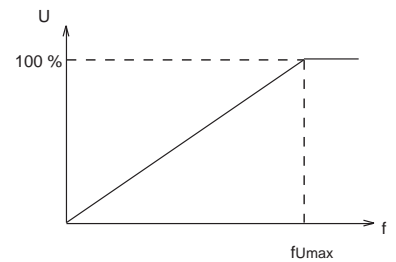

Lower modulation limit

□ □ d . 2

With it the internal frequency is defined that enables the power modules. As a result of this function a motor is never driven with frequencies below the adjusted value (dependent on user-definition).

Exception: DC-Braking can still be activated.

Range	Resolution	Standard
0...409.58 Hz	0.0125 Hz	0 Hz

Output frequency in dependence on d.2

The behaviour of the output voltage is specified with parameter P.4.

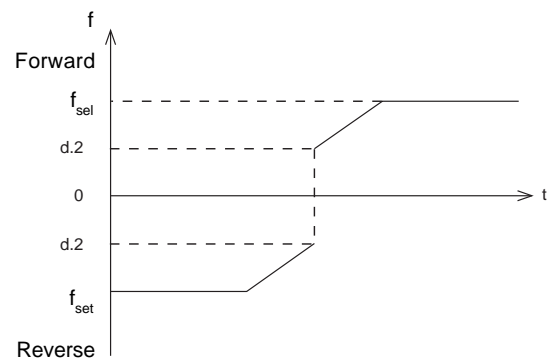

Rated motor speed

□ □ d . 5

Input of rated motor speed in conformity with the name plate of the motor.

Range	Resolution	Standard
100...25000 U/min	1 U/min	1470 U/min

Rated motor current

d.   6

Input of rated motor current in conformity with the name plate of the motor.

Range	Resolution	Standard
0.1...200.0 A	0.1 A	30.0 A

Rated motor frequency

d.   7

Input of rated motor frequency in conformity with the name plate of the motor.

Range	Resolution	Standard
20.0...3000.0 Hz	0.1 Hz	50 Hz

Rated motor cos  $\varphi$

d.   8

Input of cos ( $\varphi$ ) in conformity with the name plate of the motor.

Range	Resolution	Standard
0.50...1.00	0.01	0.86

Motor terminal resistance

d.   10

Input of the ohmic resistance between 2 phases, measured at the beginning of the motor line. The wiring of the motor (Y,  $\Delta$ ) is not taken into account - use suitable measuring equipment!

Range	Resolution	Standard
0...150.00 $\Omega$	0.01 $\Omega$	0.6 $\Omega$



Parameter d.10 can be used to calibrate the active current display r.13.

Slip compensation / frequency gain

d.   18

Specifies the amplification of frequency rise.

Range	Resolution	Standard
0.00...2.55	0.01	1.00

---- without slip compensation  
 \_\_\_ with slip compensation

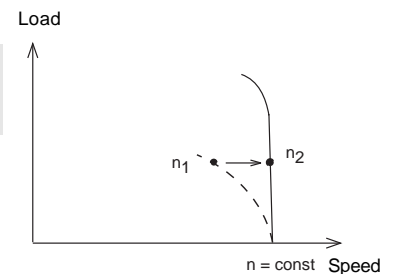

Slip compensation / auto torque gain

d.   19

Specifies the amplification of the voltage rise (Auto-Boost).

Range	Resolution	Standard
0.00...2.55	0.01	1.00

In the C (CUSTOMER)-PARAMETERS drive-specific adjustments are defined by the machine builder, that usually are not to be altered by the customer.

C.0	Limit of maximum reference A	C.18	Max. carrier frequency
C.1	Limit of maximum reference B	C.19	Vertex of min. carrier frequency
C.2	Rotation lock	C.20	Vertex of max. carrier frequency
C.3	Rotation input	C.21	Watchdog time
C.4	Condition display	C.22	Set value offset
C.5	Noise filter / digital inputs	C.23	Noise filter / analog inputs
C.7	DC-braking mode	C.25	Control word activation
C.9	Parameter group lock	C.28	Switching hysteresis
C.10	Output voltage stabilization	C.29	Display scaling / activation
C.12	Baud rate	C.30	Display scaling / multiplier
C.13	Inverter address	C.31	Display scaling / Divisor
C.14	Zero clamp speed	C.32	Display scaling / offset
C.15	Select mode of modulation	C.33	Display scaling / post decimal position
C.17	Min. carrier frequency	C.34	Parameter set lock

Limit of maximum reference A

□ □ C. 0

It defines, independent of maximum reference (o.2), the max. permissible reference limit for rotational direction forward. The inverter cannot output a higher frequency than the frequency adjusted under C.0 for rotational direction forward.

Range	Resolution	Standard	Particularity
0...409.58 Hz	0.0125 Hz	409.58 Hz	dependent on user-definition

Limit of maximum reference B

□ □ C. 1

Like C.0, but for direction of rotation reverse.

If  $(C.0/C.1) < (o.2/o.4)$ , then  $(C.0/C.1)$  define the maximum reference value. However,  $(o.2/o.4)$  continue to serve for the calculation of the reference value.

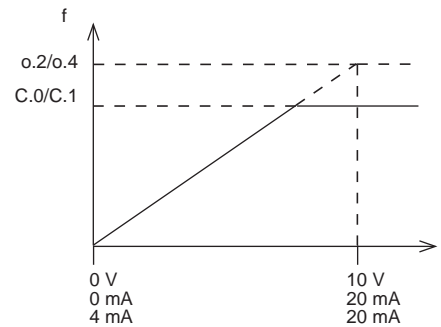

Rotation lock

□ □ C. 2

If a drive shall in no case change its rotational direction, one direction of rotation can be locked to prevent an inadvertent wrong operation. When selecting the locked rotational direction the inverter trips to LS.

Indication	Function	Standard
F r	no direction of rotation locked	Standard
F -	only direction of rotation <i>forward</i> enabled	
- r	only direction of rotation <i>reverse</i> enabled	
- -	no direction of rotation enabled	



With respect to the installation it is imperative to wire the motor terminals U, V, W in the correct sequence. The function doesn't detect the wrong direction of rotation due to mixed up motor lines!

Rotation input

□ □ C. 3

In dependence on C.3 the input terminals X1.10 and X1.11 can be adjusted internally to the following functions.

C.3	Terminal X1.10	Terminal X1.11	
0	Stop / Run	Forward / Reverse	
1	Forward	Reverse	Standard

Condition display

□ □ C. 4

Any chosen r-parameter can be specified, which will then automatically appear in the display at every restart.

Range	Function	Standard
0...35	$\hat{=}$ r.0...r.35	r.1

Noise filter / digital inputs

□ □ C. 5

The noise filter reduces the sensitivity against interferences on the digital control inputs. With this parameter the response time of the inputs is adjusted.

Calculation of response time: ((adjusted value + 1) • 3,5) ms

During the response time a constant input status must exist before a signal is accepted. Constant input status means, that none of the terminals ST, RST, F, R, I1...I4 changes its circuit state.

Range	Resolution	Standard
0...15	1	0

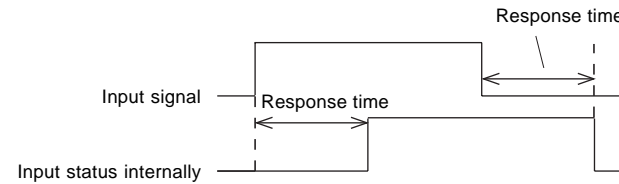

DC-braking mode

□ □ C. 7

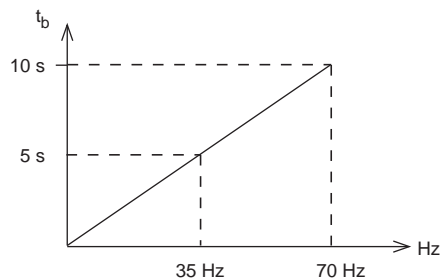

$$t_B = \frac{L.8 \cdot f_{ist}}{0.2}$$

$t_B$ : actual braking time  
 L.8: adjusted braking time  
 0.2: reference minimum A

DC-Braking allows the fast deceleration of the motor. The function can be activated through following conditions:

C.7	Function
0	no DC-braking
1	DC-braking after disabling the rotational direction and when $f = 0$ Hz for the time adjusted with L.8, provided no new rotational direction is preset.
2	DC-braking after disabling rotational direction. Braking time is dependent on the actual frequency.
3	DC-braking as soon as rotational direction changes. Braking time is dependent on the actual frequency.
4	DC-braking after disabling rotational direction and if $f_{actual} < L.6$ . Braking time is dependent on the actual frequency.
5	DC-braking, if $f_{actual} < L.6$ . The braking time is dependent on the actual frequency.
6	DC-braking, if $f_{set} < L.6$ . The braking time is dependent on the actual frequency. Restart after $f_{set} > L.6$ .
7	DC-braking on activating a digital input (I1...I4, see parameters H.12...15). The braking time is dependent on the actual frequency. Restart after input is deactivated
8	DC-braking as long as a digital input is active (I1...I4, see parameters H.12...15).
9	DC-braking for the adjusted time L.8 after enabling the modulation (control release and direction of rotation).

## Parameter group lock

□ □ C. 9

This parameter allows the disabling of parameter groups that are usually accessible with the set-up password. Consequently, the user password or the customer password must be entered in order to carry out adjustments. This gives the user the possibility to protect the parameters that are especially critical for the application.

Range	Resolution	Standard
0...31	1	0
Parameter group to be disabled	Value	Example
r-Parameters *)	$2^0 = 1$	
o-Parameters	$2^1 = 2$	-> 2
P-Parameters	$2^2 = 4$	-> 4
H-Parameters	$2^3 = 8$	
L-Parameters	$2^4 = 16$	-> 16
		C9. = 22

\*) Exception:  
r.6, r.8...r.11, r.21,  
r.22

In the example all o-, P- and L-Parameters have been disabled for the set-up password.

## Output voltage stabilization

□ □ C. 10

This parameter allows the adjustment of a regulated output voltage in reference to the corner frequency d.0. As a result voltage fluctuations at the input and in the intermediate circuit have little impact on the output voltage (U/f characteristic). Among other things, the function may permit an adaption of the output voltage to special motors. In the following example the output voltage is stabilized to 230 V.

Range	Resolution	Standard
150...649 V, oFF	1 V	oFF

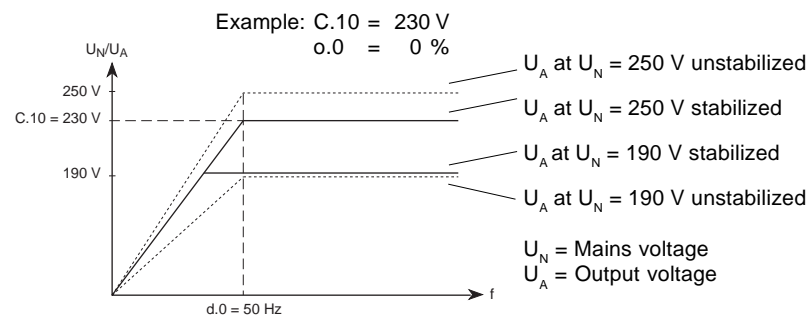

## Baud rate

□ □ C. 12

Definition of the baud rate for the serial interface of the control board.

Setting range	Value	Standard
0	1200 Baud	
1	2400 Baud	
2	4800 Baud	
3	9600 Baud	Standard

## Inverter address

□ □ C. 13

Definition of the address, under which the inverter is addressed during bus operation.

Range	Resolution	Standard
0...239	1	1

Zero clamp speed

C.14

A zero point hysteresis of the analog setpoint inputs is adjusted with this parameter. Voltage fluctuations and hum voltages around the zero point do not cause the drifting of the motor.

Range	Resolution	Standard
0...31	1	0

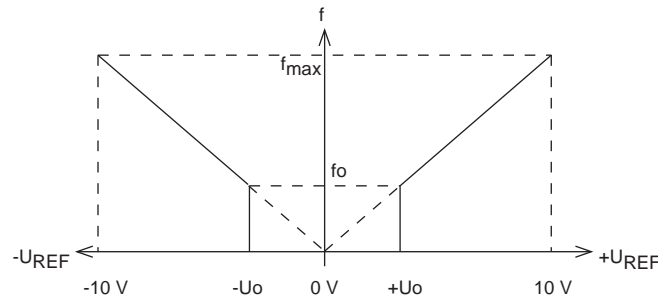

$$U_0 = C.14 \cdot 10 \text{ mV}$$

Select mode of modulation

C.15

The adjustment of the modulation procedure depends on the application. The modulation procedure can be changed on-line.

Advantages and disadvantages of the various procedures:

C.15	$f < f_{Umax}$						$f \cdot f_{Umax}$					
	U	M	S	L	T <sub>M</sub>	T <sub>U</sub>	U	M	S	L	T <sub>M</sub>	T <sub>U</sub>
0/1	+	+	+	+	+	-	•	•	•	•	•	•
2/3	•	•	•	•	•	•	•	•	•	•	•	•

C.15 = 0 or 1    2-switch modulation  
 C.15 = 2 or 3    3-switch modulation

- Standard
- + Increased
- Decreased

- U = Output voltage
- M = Torque
- S = Crest factor
- L = Noise development
- T<sub>M</sub> = Motor heating
- T<sub>U</sub> = Inverter heating

Min. carrier frequency

C.17

Definition of the lower limit of the carrier frequency, with which the power modules are clocked.

Range	Resolution	Standard
0.367 kHz...C.18	1 Hz	0.830 kHz

Max. carrier frequency

C.18

Definition of the upper limit of the carrier frequency.

Range	Resolution	Standard
C.17...2 kHz/16 kHz*	1 Hz	0.830 kHz

\* dependent on power circuit

Vertex of min. carrier frequency

C.19

Definition of the lower vertex of the output frequency. The minimum carrier frequency will be clocked from this point (dependent on user-definition).

Range	Resolution	Standard
0...C.20	0.0125 Hz	0 Hz

Vertex of max. carrier frequency

Definition of the upper vertex of the output frequency. The maximum carrier frequency will be clocked from this point (dependent on user-definition).

Range	Resolution	Standard
C.19...409.58 Hz	0.0125 Hz	0 Hz

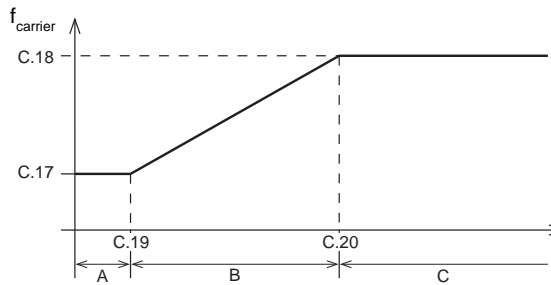

f: Actual value (r.2)  
 $f_{carrier}$ : Carrier frequency of power modules

C.17 Carrier frequency/ Minimum

C.18 Carrier frequency/ Maximum

C.19 Vertex/min. carrier frequency

C.20 Vertex/max. carrier frequency

Range A, continuous modulation with carrier frequency adjusted in C.17.

Range B, stepless increase of carrier frequency with output frequency.

Range C, continuous modulation with carrier frequency adjusted in C.18.

Watchdog time

Adjustment of the surveillance time for the bus. If no transmission takes place within the defined time (e.g. in case of master or bus error), the inverter trips to malfunction (error message E.bUS).

Range	Resolution	Standard
OFF, 0.05...9.95 s	0.05 s	OFF

Set value offset

Allows the shifting of the setpoint value/frequency characteristic in both directions (dependent on user-definition).

Range	Resolution	Standard
-100.0...+100.0 Hz	0.0125 Hz	0 Hz

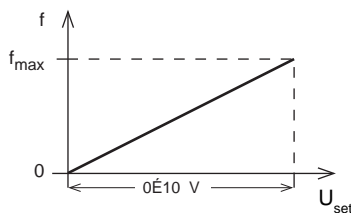

no setpoint offset C.22 = 0

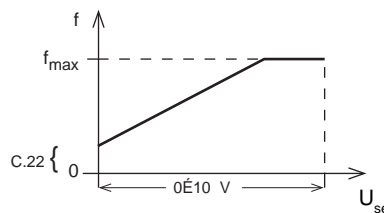

pos. setpoint offset C.22 > 0  
 and direction of rotation = forward  
 or  
 neg. setpoint offset C.22 < 0  
 and direction of rotation = reverse

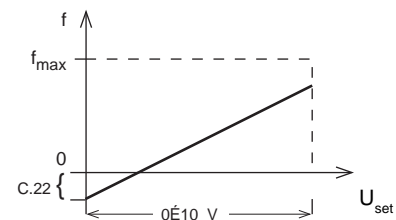

neg. setpoint offset C.22 < 0  
 and direction of rotation = forward  
 or  
 pos. setpoint offset C.22 > 0  
 and direction of rotation = reverse



The direction of rotation can change solely in dependence on the setpoint value. If necessary activate rotation lock in C.2.



Noise filter / analog inputs

To suppress interferences at the analog outputs a noise filter can be activated with C.23.

Value	Function
0	2 <sup>0</sup> = 1 Sampling intervals
1	2 <sup>1</sup> = 2 Sampling intervals
2	2 <sup>2</sup> = 4 Sampling intervals
3	2 <sup>3</sup> = 8 Sampling intervals    Standard
4	2 <sup>4</sup> = 16 Sampling intervals
5	2 <sup>5</sup> = 32 Sampling intervals

An average value is formed with the adjusted sampling intervals.  
Standard: 8 Sampling intervals • 3,5 ms = 28 ms

Control word activation

This parameter switches the inverter into the DRIVECOM mode. In the DRIVECOM mode the inverter reacts to a control word (Pr.6), which is preset via the bus profile parameters. For reasons of safety the control release must also be bridged with hardware.

Range: OFF, ON  
Standard: OFF



For activated control word the status displays (r.1)

Switching hysteresis

Defines how much the frequency may change, before a frequency-dependent output or the status display change over (e.g. from constant operation to deceleration) (dependent on user-definition).

Range	Resolution	Standard
0...100.0 Hz	0.0125 Hz	0.5 Hz

Display scaling / activation

Changes the inverter display from the standard indication of frequency to user-defined quantities. All parameters that are characterized as dependent on user-definition are changed.

Value	Function	Standard
OFF	Standard indication in frequencies	Standard
ON	User-definable indication (C.30...C.33)	

For activated function the parameters to be adjusted are calculated according to following formula:

$$\text{desired display value at frequency } f = (f \cdot 80 + C.32) \cdot \frac{C.30}{C.31}$$

Example: 1500 min<sup>-1</sup> shall be displayed at 50 Hz    C.30 = 3, C.31 = 8, C.32 = 0



If the scaling definition for the display exceeds the display range, following overflow indications appear:

Range exceeded for rotational direction forward.  
  Range exceeded for rotational direction reverse.

Display scaling / multiplier

□□ C.30

Serves for the multiplication of the non-normalized value.

Range	Resolution	Standard
-9999...9999	1	1500

Display scaling / divisor

□□ C.31

Serves for the division of the non-normalized value.

Range	Resolution	Standard
1...9999	1	4000

Display scaling / offset

□□ C.32

C.32 can put an offset on the non-normalized value.

Range	Resolution	Standard
-9999...9999	1	0

Display scaling / post decimal position

□□ C.33

In conformity with the required accuracy up to four post decimal positions can be indicated.

Range	Resolution	Standard
0...4	1	1

For programming examples refer to Special Settings Scaling of Display.

Parameter set lock

□□ C.34

This parameter allows the disabling of one or several parameter sets. The selection of a disabled parameter set via keyboard, terminal strip or bus triggers a set selection error (ES.x).

The disabling of parameter sets is binary-coded.

Parameter set	Value	Example
0	$2^0 = 1$	-> 1
1	$2^1 = 2$	
2	$2^2 = 4$	
3	$2^3 = 8$	-> 8
4	$2^4 = 16$	
5	$2^5 = 32$	-> 32
6	$2^6 = 64$	
7	$2^7 = 128$	
	Display=	41

To disable several parameter sets simultaneously enter the sum of their values. In the example the sets 0, 3 and 5 are disabled.

c (CONTROL)-PARAMETERS are for the adjustment of the regulator and for the Power-off function.

c.8	Regulator selection	c.20	Power off / load-dependent frequency jump factor
c.10	P (Power off)	c.21	Power off / initial ramp speed
c.11	I (power off)	c.22	P (DC-braking)
c.12	Power off / Mode	c.23	I (DC-braking)
c.13	Power off / set DC voltage		
c.14	Power off / DC tripping voltage		
c.15	Power off / initial ramp time		
c.16	Power off / frequency jump		
c.17	Power off / frequency-dependent ramp correction		
c.18	Power off / load-dependent ramp correction		
c.19	Power off / min. restart limit		

Regulator selection



Serves to activate the Auto-Boost (= magnetizing current control) as well as the slip compensation.

Value	Function	Standard
0	Regulator off	Standard
1	Auto-Boost on	
2	Auto-Boost and slip compensation on	
3	Auto-Boost and slip compensation on	

Refer to Special Settings for description of function and adjustment of Power-off function

P (Power off)



Proportional factor, it serves to regulate the intermediate circuit voltage to the level adjusted in c.13 at power-off function.

Range	Resolution	Standard
0...255	1	0

I (Power off)



Integral factor, it serves to regulate the intermediate circuit voltage to the level adjusted in c.13 at power-off function.

Range	Resolution	Standard
0...255	1	0

Power off / mode



Specifies the mode for the power-off function.

Value	Function	Standard
0	No power-off function	Standard
1	Setting mode	
2	Standard operation	



To utilize the power-off function for units including size 22 of the F-series observe the switch position in the power circuit! As of size 23 the power-off function is no longer supported.

Units of the 56-series require an alteration of the wiring for the error detection (special version).

Power off / set DC voltage

c.   13

Defines the value of the intermediate circuit voltage to be regulated to at power off.

Range	Resolution	Standard
100...150 %	1 %	100 %

Power off / DC tripping voltage

c.   14

When falling below the adjusted value of the intermediate circuit voltage the power-off function starts.

Range	Resolution	Standard
50...100 %	1 %	80 %

Power off / initial ramp time

c.   15

Together with c.21 it defines the  $\Delta f/\Delta t$  for the initial ramp time at power off.

Range	Resolution	Standard
0.05...999.5 s	0.05 s	41 s

Power off / frequency jump

c.   16

Defines the size of the frequency jump that is given out at the beginning of the power-off function (dependent on user-definition).

Range	Resolution	Standard
0.000...25.000 Hz	0.0125 Hz	2.000 Hz

Power off / frequency-dependent ramp correction

c.   17

Defines the degree of frequency-dependency of the initial ramp (only for c.12 = 2).

Value	Function
0	Ramp corresponds to the ramp adjusted under c.15 and c.21 in the setting mode (c.12 = 1).
1...4095	For smaller frequencies the ramp time becomes shorter in proportion to it (up to factor 4).

Power off / load-dependent ramp correction

c.   18

Defines the degree of load-dependency of the initial ramp (only for c.12 = 2).

Value	Function
0	Ramp corresponds to the ramp adjusted under c.15 and c.21 in the setting mode (c.12 = 1).
1...4095	For larger loads the ramp time becomes shorter (up to factor 4).

Power off / min. restart limit

c.   19

If the frequency drops below the adjusted value at activated power-off function, the drive will not run up after voltage recovery (Condition: voltage is still supplied to the control; display is not dark). Above the value the drive accelerates with the adjusted acceleration time to the setpoint value (dependent on user-definition).

Range	Resolution	Standard
0...409.58 Hz	0.0125 Hz	0 Hz

Power off / load-dependent  
frequency jump factor

c.20

To ensure that the motor, with increasing load, safely reaches regenerative operation, a load-dependent frequency-jump factor can be specified (only for c.12 = 2).

Range	Resolution	Standard
0...4095	1	0

Power off / initial ramp speed

c.21

Together with c.15 it defines the  $\Delta f/\Delta t$  for the initial ramp (dependent on user-definition).

Range	Resolution	Standard
1.25...409.58 Hz	0.0125 Hz	70 Hz

P (DC-braking)

c.22

Proportional factor of braking current regulator.

Range	Resolution	Standard
0...255	1	12

I (DC-braking)

c.23

Integral factor of braking current regulator.

Range	Resolution	Standard
0...255	1	6



The P-component and I-component of the braking current regulator are adjusted for operation with standard motors. For special motors (e.g. MF-motors) or when problems arise (e.g. OC error) during DC-braking, an adaption of the regulator parameters may be required.

## F (FREE PROGRAMMABLE)-PARAMETERS

serve to program and to copy parameter sets.

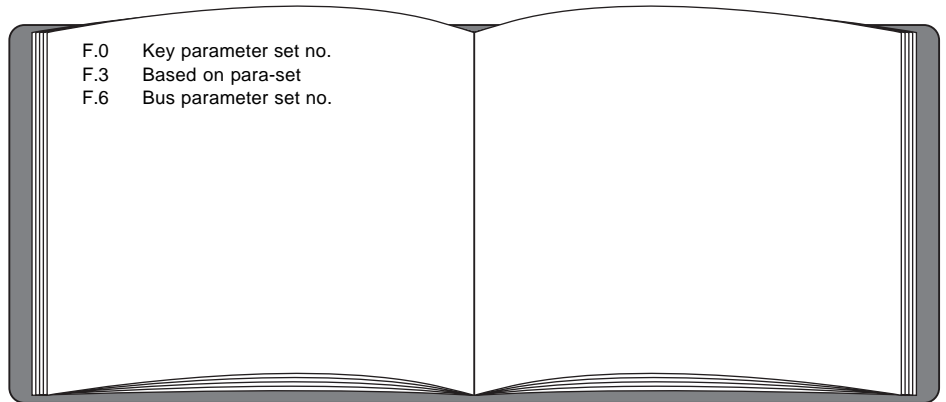

The control board includes 8 parameter sets (sets 0...7). All parameters of a selected parameter set can be changed. To prevent inadvertent wrong operation, certain parameters affect all sets, regardless in which set the alteration was performed (e.g. occupancy of digital inputs). These parameters are described as Global Parameters.

### Listing of all global parameters

r.0	r.18	o.18	C.3	c.10	F.0	I.0
r.1	r.21		C.4	c.11	F.3	I.1
r.2	r.22	P.18	C.5	c.12	F.6	I.2
r.3	r.23		C.9	c.13		I.3
r.4	r.27	H.0	C.12	c.14		I.4
r.5	r.28	H.7	C.13	c.15		I.5
r.6	r.29	H.12	C.14	c.16		I.6
r.7	r.30	H.13	C.21	c.17		I.7
r.8		H.14	C.23	c.18		I.8
r.9		H.15	C.25	c.19		I.9
r.10		H.16	C.29	c.20		I.10
r.11		H.17	C.30	c.21		I.11
r.12			C.31	c.22		I.12
r.13			C.32	c.23		I.13
r.14			C.33			I.14
r.15			C.34			I.15
						I.16

Key parameter set no.



Selection of a parameter set, that shall be programmed by keyboard. All parameters show the value of the parameter set adjusted here, even if at the same time another parameter set is active.

If F.0 is set to A, the values of the active parameter set are indicated but they cannot be changed.

Range	A, 0...7
Standard	0



The parameter adjusted last is stored and loaded after a restart.

Based on para-set

□ □ F. 3



Minimum password level 3 required! (refer to page E20)

This parameter serves to copy parameter sets. The source set is adjusted that shall be copied to the destination set.

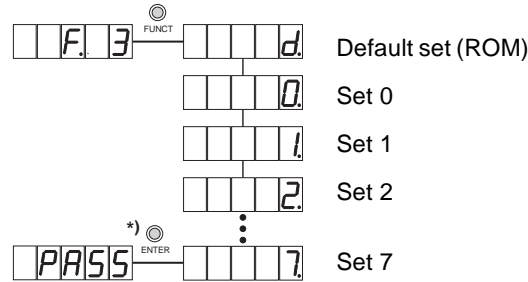

\*) With ENTER the indicated parameter set (source) is copied to the set (destination) adjusted under F.0. After completed duplication the display indicates PASS (also see F.6). In case of wrong input the message nco (not copied) is indicated.

The default set is stored internally in the ROM. This set allows the reinitialization of all sets, inclusive the standard set (set 0). This also results in the overwriting of the standard setting ex factory.

For copying the default set to the sets 1..7 the global parameters are not overwritten.



To copy the default set the control release must be open

Bus parameter set no.

□ □ F. 6

This parameter is visible and can be written on only by bus. Analog to parameter F.0 the set that shall be modified by bus is selected here.

## I (INFORMATION)-PARAMETERS

specify the frequency inverter and indicate errors.

I.0	Inverter type	I.13	Error counter FU
I.1	Rated inverter current display	I.14	Error counter OH2
I.2	Output frequency limit display	I.15	Software identification
I.3	Error counter OP	I.16	Software date
I.4	Error counter UP		
I.5	Error counter OC		
I.6	Error counter OH		
I.7	Error counter OL		
I.8	Error counter set selection		
I.9	Error counter watchdog		
I.10	Error counter UP1		
I.11	Error counter OC1		
I.12	Error counter OH1		

Inverter type

□ □ I . 0

Describes the series and voltage class of the inverter.

Display	Unit	Display	Unit
□ □ F I . 2	F1, 200 V class	□ □ 56 d . 4	56, 400 V class
□ □ F I . 4	F1, 400 V class	□ S P E C I	Special version
□ □ 56 d . 2	56, 200 V class	□ n o I d	no identification

Rated inverter current display

□ □ I . 1

Indication of rated inverter current in ampere.

Output frequency limit display

□ □ I . 2

Indication of maximum permissible output frequency in Hz.

Error counter OP

□ □ I . 3

Indication of total number of OP errors.

Error counter UP

□ □ I . 4

Indication of total number of UP errors.

Error counter OC

□ □ I . 5

Indication of total number of OC errors.

Error counter OH

□ □ I . 6

Indication of total number of OH errors.



Error counter OL



Indication of total number of OL errors.

Error counter set selection



Indication of total number of set selection errors.

Error counter watchdog



Indication of total number of watchdog errors.

Error counter UP1



Indication of total number of UP1 errors.

Error counter OC1



Indication of total number of OC1 errors.

Error counter OH1



Indication of total number of OH1 errors.

Error counter FU



Indication of total number of FU errors.

Error counter OH2



Indication of total number of OH2 errors.

Software identification



This parameter identifies the software used on the control. The displayed value allows the correct configuration of the operator interface KEB COMBIVIS.

Display	Configuration
8	F0 / F1 / 56D / 56D V1.2 (up to COMBIVIS version 3.1)
25	F1 / 56D / 58D V1.2 (starting with COMBIVIS version 3.2)

In the system configurator of COMBIVIS the configuration corresponding to the display must be adjusted; this adjustment takes place automatically when calling COMBIVIS and with connected inverter.

Software date



Displays the date of the installed software.

Example:

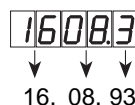
  
 16. 08. 93

## Pr (PROFIL)-PARAMETERS

correspond to the entsprechen der DRIVECOM specification. They are intended exclusively for bus operation and are not visible on the display. The Profile Parameters can be changed without entering the password.

Pr.4 Pole number	Pr.39 Speed reference variable
Pr.5 Malfunction code	Pr.40 Actual percentage
Pr.6 Control word	Pr.41 Percentage reference variable
Pr.7 Status word	
Pr.8 Nominal speed value	
Pr.9 Actual speed value	
Pr.10 Speed-min-amount	
Pr.11 Speed-max-amount	
Pr.16 Acceleration-delta speed	
Pr.18 Acceleration-delta time	
Pr.25 Deceleration-delta speed	
Pr.27 Deceleration-delta time	
Pr.37 Speed reference variable	
Pr.38 Nominal percentage	

DRIVECOM is a user group of leading manufacturers in the drive engineering. Based on InterBus-S a uniform communication profile was specified. For a detailed description refer to the DRIVECOM specifications.

Pole number

Pr. 4

The pole number of the motor can be read.

Value range	Resolution	Status
0...12	2	Read-only parameter

Malfunction code

Pr. 5

Indicates the error code in case of malfunction. The code is listed in Annex Communication Parameter under r.1.

Value range	Resolution	Status
0...65535	1	Read-only parameter

Control word

Pr. 6

The control word serves to control the state of the inverter by bus. For the inverter to react to the control word, it must be activated with parameter C.25 (C.25 = on).

Value range	Resolution	Standard	Range
0...65535	1	0	0...65535

Status word

Pr. 7

With the status word the condition of the inverter is read out.

Value range	Resolution	Status
0...65535	1	Read-only parameter

Nominal-speed value

Pr. 8

Presetting of desired speed in U/min. The direction of rotation is determined by the sign.

Value range	Resolution	Speed range
-32768...32767	1	-32768...32767 U/min

Actual-speed value

Pr. 9

Output of the current speed. The direction of rotation is determined by the sign.

Value range	Resolution	Status
-32768...32767	1	Read-only parameter

Speed-min amount

Pr.10

Presetting of minimum speed for both rotational directions.

Value range	Resolution	Standard	Speed range
0...32767	1	0 U/min	0...Pr.11

Speed-max amount

Pr.11

Presetting of the maximum speed for both rotational directions.

Value range	Resolution	Standard	Speed range
0...32767	1	2100 U/min	Pr.10...32767 U/min

Acceleration-delta speed

Pr.16

Presetting of speed change, which serves together with Pr.18 for the calculation of the acceleration ramp.

Value range	Resolution	Standard	Speed range
0...32767	1	2100 U/min	0...32767 U/min

Acceleration-delta time

Pr.18

Presetting of the time used for the calculation of the acceleration ramp.

Value range	Resolution	Standard	Speed range
0...999	1	10 s	0...999 s

Deceleration-delta speed

Pr.25

Like Pr.16, but for the calculation of the deceleration ramp.

Deceleration-delta time

Pr.27

Like Pr.18, but for the calculation of the deceleration ramp.

Speed reference variable

Pr.37

Speed at the output of the ramp generator.

Value range	Resolution	Status
-32768...32767	1 U/min	Read-only parameter



The parameters Pr.10...Pr.27 are set-dependent. An alteration of the parameters Pr.10...Pr.27 results in a change of the parameters o.1...o.12!

When changing the o-parameters o.1...o.12, the values for the rotational direction forward are included in the Pr-parameters!

Nominal percentage

Pr.38

Setpoint value setting in percent in reference to Pr.39.

Value range	Resolution	Standard	Range
-32768...32767	1	0 %	-200 %...200 %

16383  $\triangleq$  100 % = Pr.39

The setpoint value is calculated according to following formula:

$$\text{Setpoint value} = \frac{\text{Reference value (Pr.39)} \cdot \text{Percentage (Pr.38)}}{100 \%}$$

Speed reference variable

Pr.39

Determination of the speed value that applies to Pr.38 as 100 % value.

Value range	Resolution	Standard	Range
0...32767	1	2100 U/min	0...32767 U/min

Actual percentage

Pr.40

Actual value in percent in reference to Pr.38.

Value range	Resolution	Range	Status
-32768...32767	1	-200 %...200 %	Read-Only-Parameter

16383  $\triangleq$  100 % = Pr.39

Percentage reference variable

Pr.41

Actual value in percent at the output of the ramp generator in reference to Pr.39.

Value range	Resolution	Range	Status
-32768...32767	1	-200 %...200 %	Read-Only-Parameter

16383  $\triangleq$  100 % = Pr.39

<p><b>Connection of Control Board</b> Page E4 - E14</p> <p><b>Operation of the Unit</b> Page E15 - E22</p> <p><b>Starting</b> Page E23 - E30</p> <p><b>Parameter</b> Page E31 - E68</p> <p><b>✓ Special Settings</b> Page E69 - E112</p> <p><b>Annex</b> Page E113 - E122</p> <p><b>Index</b> Page E123 - E124</p>
------------------------------------------------------------------------------------------------------------------------------------------------------------------------------------------------------------------------------------------------------------------------------------------------------------------------------------------------



Reference value and direction of rotation	E70-E75
Ramp setting	E76-E77
Digital outputs	E78-E79
Analog output	E80-E81
Programmable inputs	E82-E84
DC-Braking	E85-E86
Ramp stop	E87
Current limit	E88-E89
Speed search and automatic retry	E90-E91
Motor protective function	E92
Energy-saving function	E93
Autoboost and slip compensation	E94-E95
Modulation	E96
Scaling of display	E97-E98
Power-off function	E99-E101
Programming of parameter sets	E102
Bus operation	E103-E105
Communication parameters	E106-E111
Control word and status word	E112

The function-specific parameterizing is intended for the user who is accustomed with the fundamental handling and operation of the unit. It shows all the possibilities to utilize fully the functional extent of the KEB COMBIVERT.

## REFERENCE VALUE AND DIRECTION OF ROTATION

The presetting of reference value and direction of rotation can be influenced in its behaviour in various ways.

Block diagramm

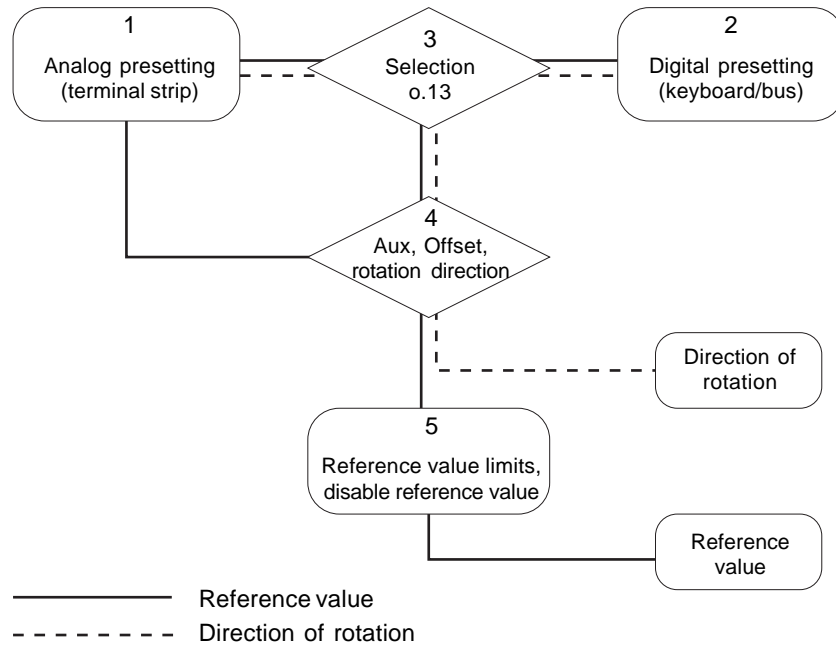

- Block 1: Includes all parameters for the presetting of analog reference value and direction of rotation.
- Block 2: Includes all parameters for the presetting of digital reference value and direction of rotation.
- Block 3: Parameter o.13 which defines whether the presetting shall be done analog and/or digital.
- Block 4: Describes the effect of the analog AUX-input on the reference value and the direction of rotation.
- Block 5: Includes all parameters that restrict the reference value to a certain range of effectiveness.

Block 1:  
Analog presetting of reference value  
and direction of rotation

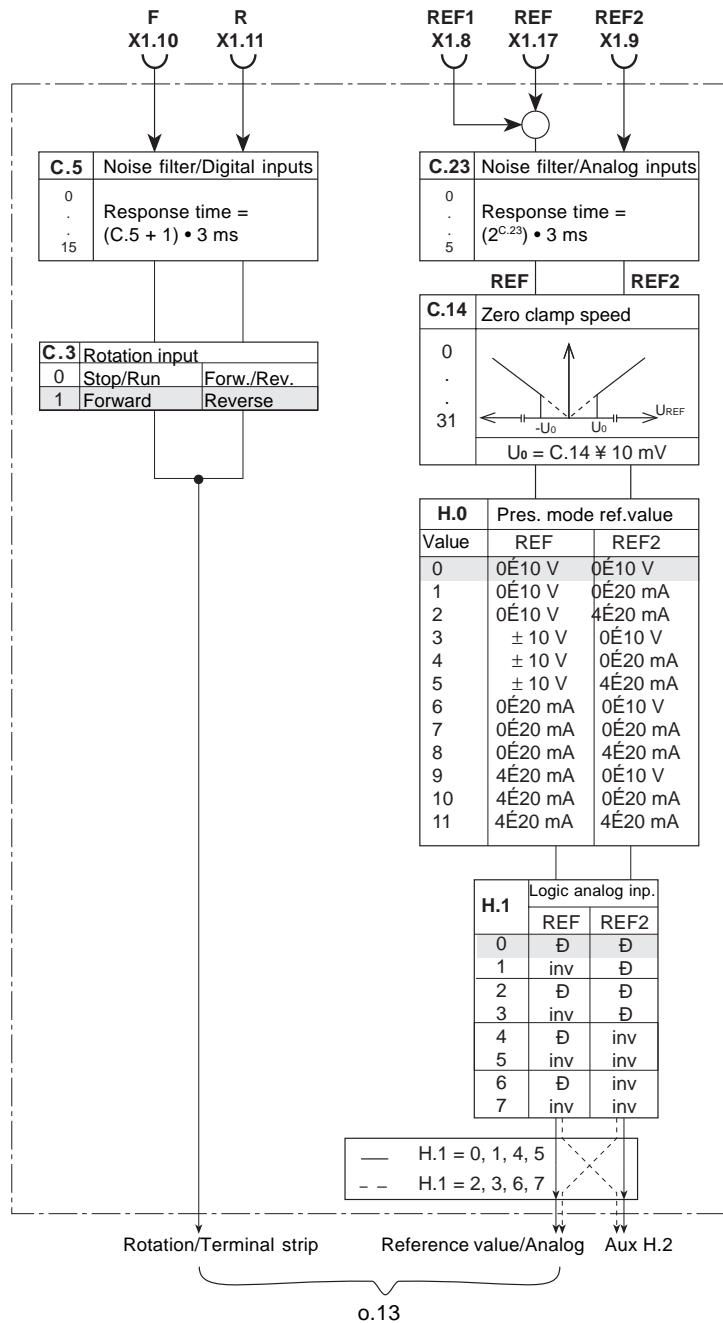

**Functional description**

**Direction of rotation:** The direction of rotation is defined with terminals X1.10 and X1.11. The input signals of the digital inputs (F, R, ST, RST, I1...I4) must apply for the entire duration of the response time (C.5) before an input is considered as set. With C.3 the function of the terminals is specified.



For ±10V signal (H.3 = 3...5) adjust o.13 = 4.

**Reference value:** The terminals X1.8 and X1.17 are added up sign-correct by the hardware and then transferred together with REF2 to the noise filter C.23. Here an average value is formed with the response time.

With C.14 the ripple voltages around the zero point can be blanked out. Especially with ±10 V presetting a safe standstill of the motor can be adjusted.

H.0 is adjusted to the used analog signals. With H.1 the analog signals can be inverted (10V ∅ 0V Δ f<sub>min</sub> ∅ f<sub>max</sub>). In addition to it, it is specified whether REF or REF2 are internally processed as reference value input or AUX input.

## Block 2: Digital presetting of reference value and direction of rotation

Digital presetting by keyboard or bus

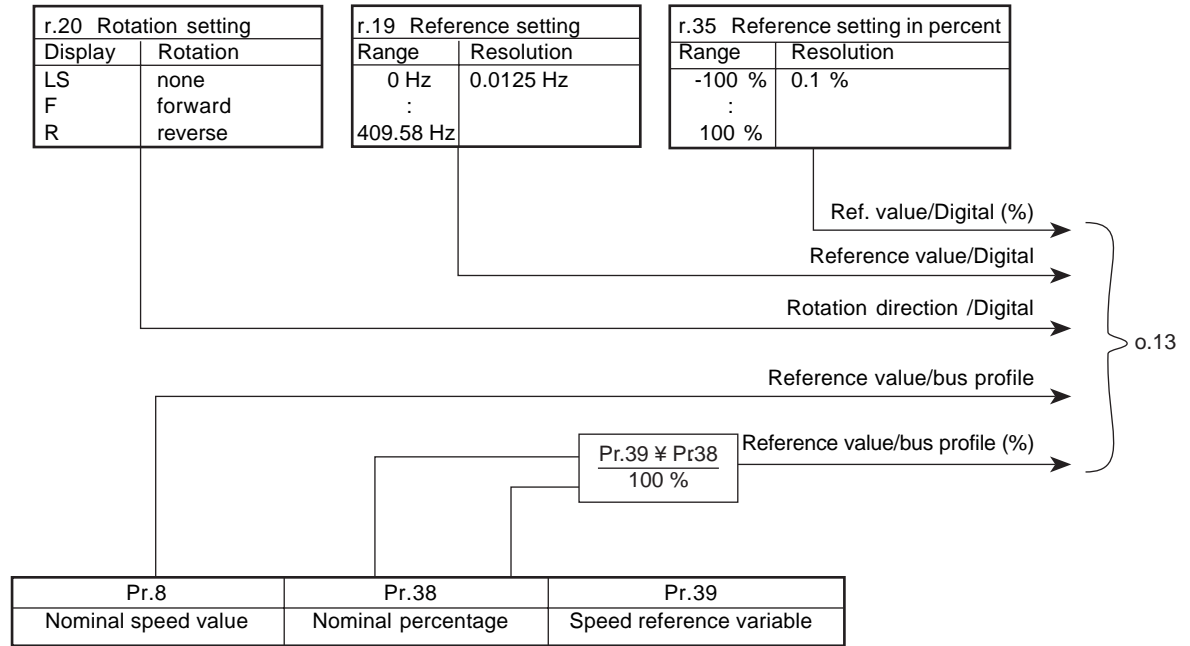

Presetting by bus profile parameters only for DRICEVOM user group!

### Functional description

**Direction of rotation:** The presetting of the direction of rotation is done with parameter r.20 (keyboard or bus) or sign-dependent from the reference value.

**Reference value:** The digital reference value can be preset either user-defined with r.19 (standard setting in Hz) or in percentage with r.35 (100 % = maximum reference value).

For DRIVECOM users the reference setting is done with Pr.8 in speeds or in percentage with Pr.38. The value that Pr.38 refers to must first be specified with Pr.39.



Block 3: Selection

The selection of reference value and direction of rotation (digital, analog or bus protocol) is done with parameter o.13. It switches through one of the possible presetting signals for reference value and direction of rotation from block 1 and block 2 for further processing. Parameter o.13 can be adjusted differently in the parameter sets.

o.13 Art der Sollwert-/Drehrichtungsvorgabe		
Value	Reference value	Rotation direction
0	Digital (r.19)	Digital (r.20)
1	Digital (r.19)	Terminal strip
2	Terminal strip	Digital (r.20)
3	Terminal strip	Terminal strip
4	±Terminal strip	Dependent on ref. value
5	±Profile parameter	Dependent on ref. value
6	Digital in % (r.35)	Digital (r.20)
7	Digital in % (r.35)	Terminal strip
8	Digital in % (r.35)	Dependent on ref. value
9	Profile parameter in % (Pr.38)	Dependent on ref. value

Block 4: AUX, Offset, rotation lock

AUX describes a 2nd reference value input which is formed either by REF + REF1 or REF2 (see block 1). With AUX the reference value can be influenced according to H.2. With the appropriate programming and the adjustment of a negative AUX-value or reference value offset it is possible to change the direction of rotation independent of the preset rotation direction by terminal strip or bus. With C.2 an unwanted rotation direction can be locked.

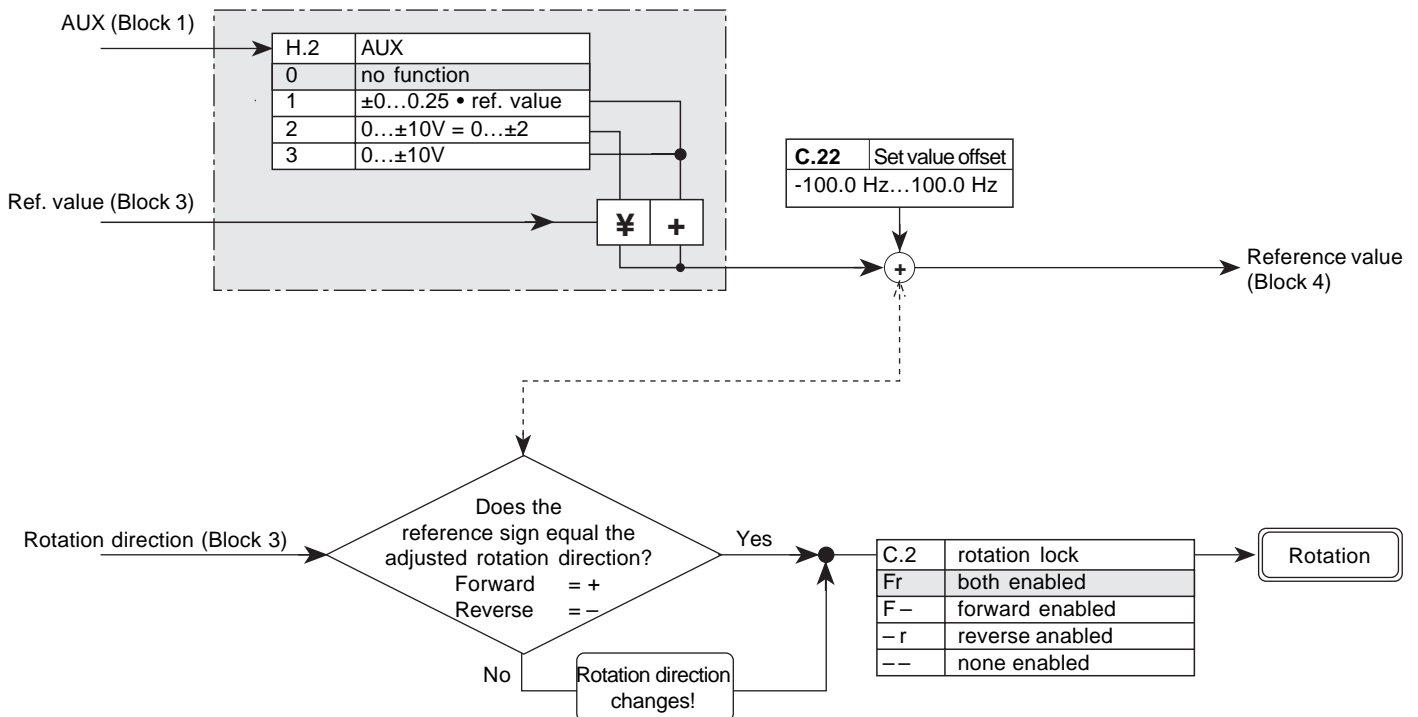

## Block 5: Reference limits, Disabling reference value

Independent of each other a reference minimum and a reference maximum (o.1...o.4) can be adjusted for each direction of rotation. With C.0 and C.1 maximum reference limits can be specified. Independent of reference minimum/maximum the values can be defined for the entire range.

As shown below o.1...o.4 serve for the calculation of the analog reference value (e.g. 0...10V = o.1...o.2). For example, adjustment of C.0 < o.2, as a result an increase of the reference voltage is without effect once C.0 is reached.

If in certain frequency ranges resonances occur at the drive unit, they can be blanked out by means of the parameters L.10...L.15 (max. 3 ranges).



With respect to the sequence of adjustment the following condition must be observed!

L.15 • L.14 • L.13 • L.12 • L.11 • L.10

Working with the factory setting (L.10...L.15) always start with L.15! Especially for download lists (COMBIVIS) this order must be observed!

If the inverter is in the acceleration or deceleration ramp the frequencies are not blanked out. Consequently no frequency jumps take place.

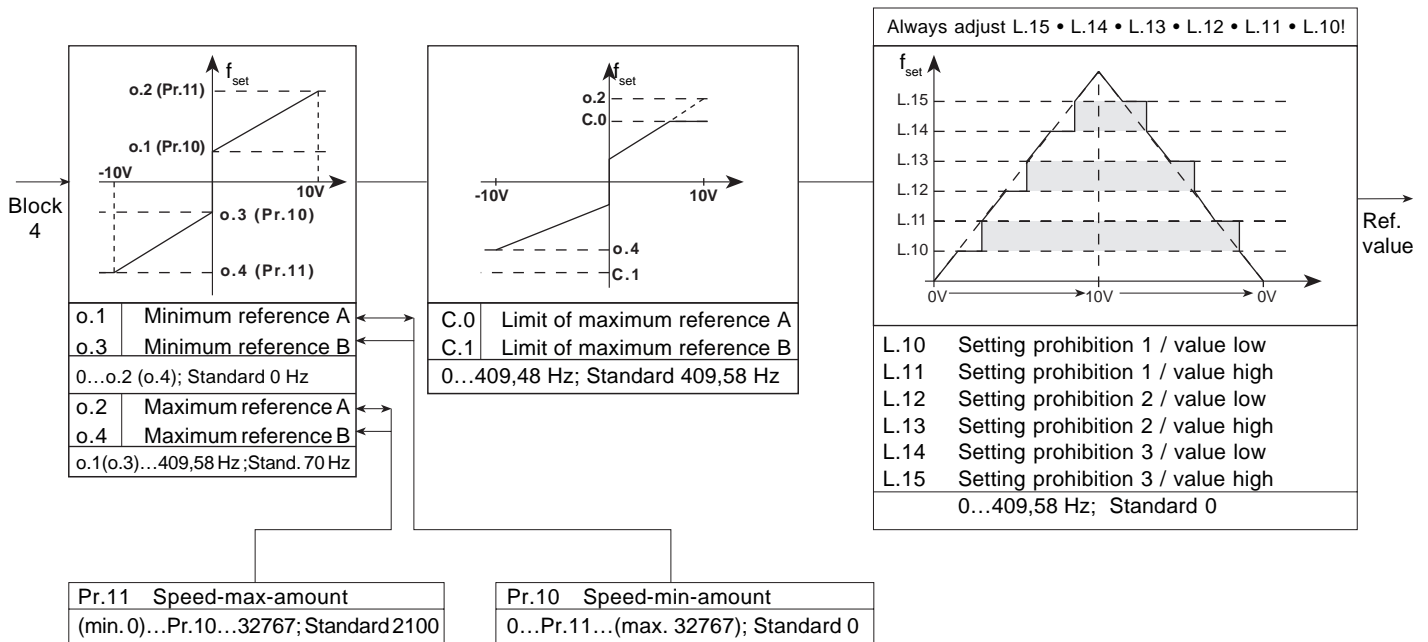

Changing the Profile Parameter Pr.10 or Pr.11 also causes a change of parameters o.1, o.3 or o.2, o.4. However, in the reverse case only the alteration of o.1 or o.2 causes a change of the Profile Parameter Pr.10 or Pr.11.

## Used Parameter

Parameter	Address	Value range	Correcting range	Resolution	Factory setting	Standard	Flags	Remarks
r.19	0213h	0...32767	0...409,58	0,0125 Hz	0 Hz	0 Hz	P, L0	depends on user-definit.
r.20	0214h	0...2	LS, F, R	1	LS	LS	P, E, L0	—
r.35	0223h	-1000...1000	-100,0...100,0	0,1 %	0 %	0 %	P, L0	—
o.1	0301h	0...32767	0...o.2(max.409,58)	0,0125 Hz	0 Hz	0 Hz	P, L3	depends on user-definit.
o.2	0302h	0...32767	0(o.1)...409,58	0,0125 Hz	70 Hz	70 Hz	P, L3	depends on user-definit.
o.3	0303h	0...32767	0...o.4(max.409,58)	0,0125 Hz	0 Hz	0 Hz	P, L3	depends on user-definit.
o.4	0304h	0...32767	0(o.3)...409,58	0,0125 Hz	70 Hz	70 Hz	P, L3	depends on user-definit.
o.13	030Ch	0...9	0...9	1	3	3	P, E, L3	—
H.0	0B00h	0...11	0...11	1	0	0	E, L3	—
H.1	0B01h	0...7	0...7	1	0	0	P, E, L3	—
H.2	0B02h	0...3	0...3	1	0	0	P, E, L3	—
L.10	0D0Ah	0...32767	0...L.11(max.409,58)	0,0125 Hz	0 Hz	0 Hz	P, L3	depends on user-definit.
L.11	0D0Bh	0...32767	0(L.10)...L.12(max.409,58)	0,0125 Hz	0 Hz	0 Hz	P, L3	depends on user-definit.
L.12	0B0Ch	0...32767	0(L.11)...L.13(max.409,58)	0,0125 Hz	0 Hz	0 Hz	P, L3	depends on user-definit.
L.13	0B0Dh	0...32767	0(L.12)...L.14(max.409,58)	0,0125 Hz	0 Hz	0 Hz	P, L3	depends on user-definit.
L.14	0B0Eh	0...32767	0(L.13)...L.15(max.409,58)	0,0125 Hz	0 Hz	0 Hz	P, L3	depends on user-definit.
L.15	0B0Fh	0...32767	0(L.15)...409,58	0,0125 Hz	0 Hz	0 Hz	P, L3	depends on user-definit.
C.0	0700h	0...32767	0...409,58	0,0125 Hz	409,58 Hz	409,58 Hz	P, L3	depends on user-definit.
C.1	0701h	0...32767	0...409,58	0,0125 Hz	409,58 Hz	409,58 Hz	P, L3	depends on user-definit.
C.2	0702h	0...3	F r, F -, - r, --	1	F r	F r	P, E, L3	—
C.3	0703h	0...1	0...1	1	1	1	P, L3	—
C.5	0705h	0...15	0...15	1	0	0	L3	—
C.14	070Eh	0...31	0...31	1	0	0	P, L3	—
C.22	0716h	-8000...8000	-100.0...100.0	0,0125 Hz	0 Hz	0 Hz	P, L3	depends on user-definit.
C.23	0717h	0...5	0...5	1	3	3	L3	—
Pr.8	0108h	-32768...32767	-32768...32767	1 rpm	0	0	L0	—
Pr.10	010Ah	0...32767	0...Pr.11(max.32767)	1 rpm	0 rpm	0 rpm	P, L0	—
Pr.11	010Bh	0...32767	0(Pr.10)...32767	1 rpm	2100 rpm	2100 rpm	P, L0	—
Pr.38	0126h	-32768...32767	-32768...32767	1	0 %	0 %	L0	$\hat{=}$ -200 %...200 %
Pr.39	0127h	0...32767	0...32767	1 rpm	0 rpm	0 rpm	P L0	—

(P = programmable Parameter L0 = no Password L3 = Customer Password R = Read-only-Parameter E = Enter Parameter)

## RAMP SETTING

The following parameters define the acceleration and deceleration ramps. For drives where a jerk-free operation is of advantage a straightening of the ramps (S-curves) can be adjusted. Changing the Profile Parameters causes the change of the o-Parameters belonging to it. However, in the reverse case only the o-Parameters o.5...o.8 change the Profile Parameters (see arrows).

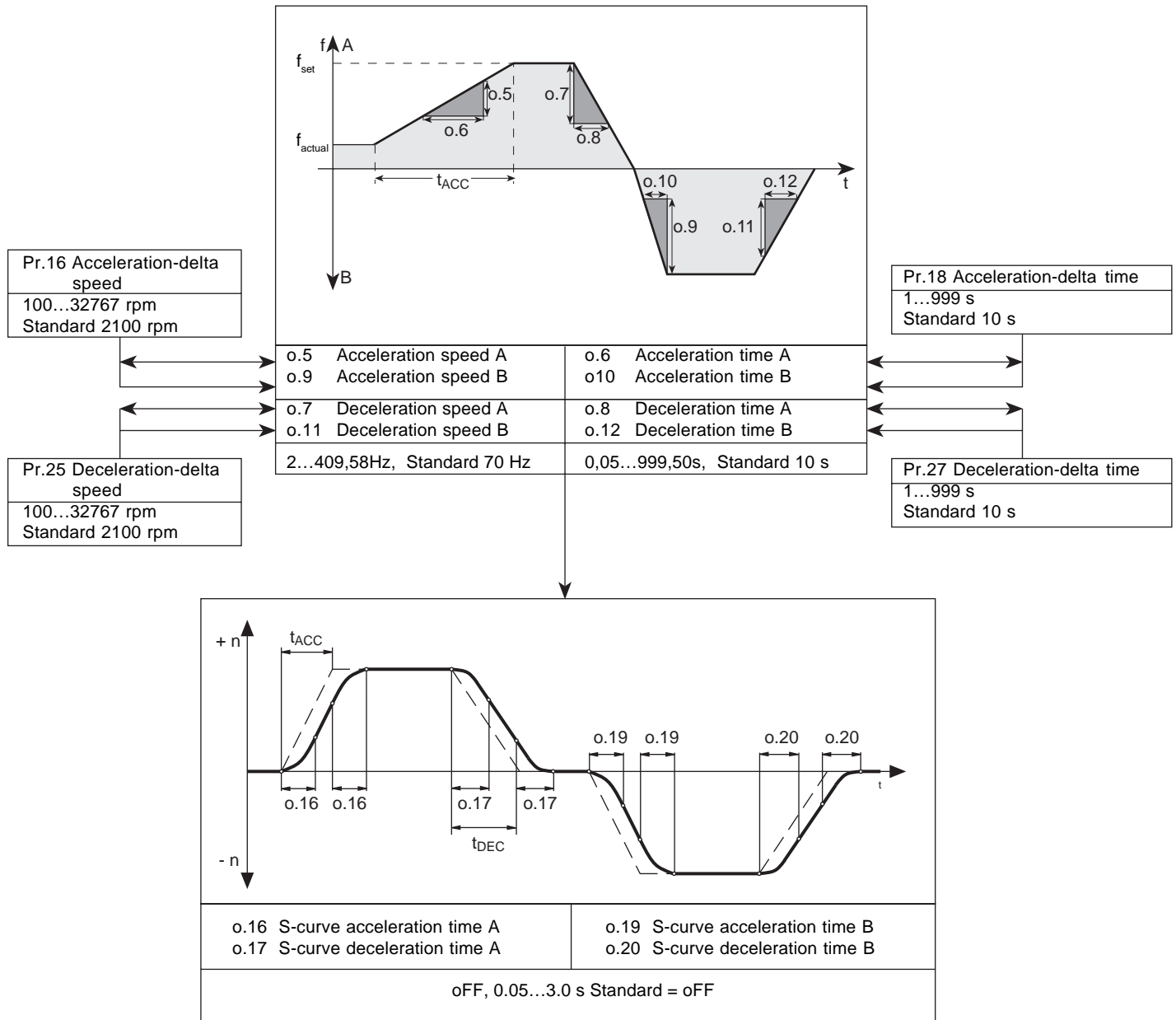

Setting example:

A drive shall accelerate within 2 seconds from 5 Hz to 50 Hz whereby a straightening shall be driven for 2 seconds.

- o.5 = 50 Hz - 5 Hz = 45 Hz
- o.6 = 5 s - 2 s = 3 s
- o.16 = 2 s

## Used Parameter

Parameter	Address	Value range	Correcting range	Resolution	Factory setting	Standard	Flags	Remarks
o.5	0305h	100...32767	2...409.58	0,0125 Hz	70 Hz	70 Hz	P, L3	depends on user-definit.
o.6	0306h	1...19990	0.05...999.5	0,05 s	10 s	10 s	P, L3	—
o.7	0307h	1...19990	0.05...999.5	0,05 s	10 s	10 s	P, L3	—
o.8	0308h	1...19990	0.05...999.5	0,05 s	10 s	10 s	P, L3	—
o.9	0309h	1...19990	0.05...999.5	0,05 s	10 s	10 s	P, L3	—
o.10	030Ah	1...19990	0.05...999.5	0,05 s	10 s	10 s	P, L3	—
o.11	030Bh	1...19990	0.05...999.5	0,05 s	10 s	10 s	P, L3	—
o.12	030Ch	1...19990	0.05...999.5	0,05 s	10 s	10 s	P, L3	—
o.16	0310h	0...60	oFF, 0.05...3.0	0,05 s	oFF	oFF	P, L3	—
o.17	0311h	0...60	oFF, 0.05...3.0	0,05 s	oFF	oFF	P, L3	—
o.19	0313h	0...60	oFF, 0.05...3.0	0,05 s	oFF	oFF	P.L3	—
o.20	314h	0...60	oFF, 0.05...3.0	0,05 s	oFF	oFF	P, L3	—
Pr.16	0110h	100...32767	100...32767	1 rpm	2100 rpm	2100 rpm	P, L0	—
Pr.18	0112h	1...999	1...999	1 s	10 s	10 s	P, L0	—
Pr.25	0119h	100...32767	100...32767	1 rpm	2100 rpm	2100 rpm	P, L0	—
Pr.27	011Bh	1...999	1...999	1 s	10 s	10 s	P, L0	—

(P = programmable Parameter L0 = no Password L3 = Customer Password R = Read-only-Parameter E = Enter Parameter)

## DIGITAL OUTPUTS

### Summary

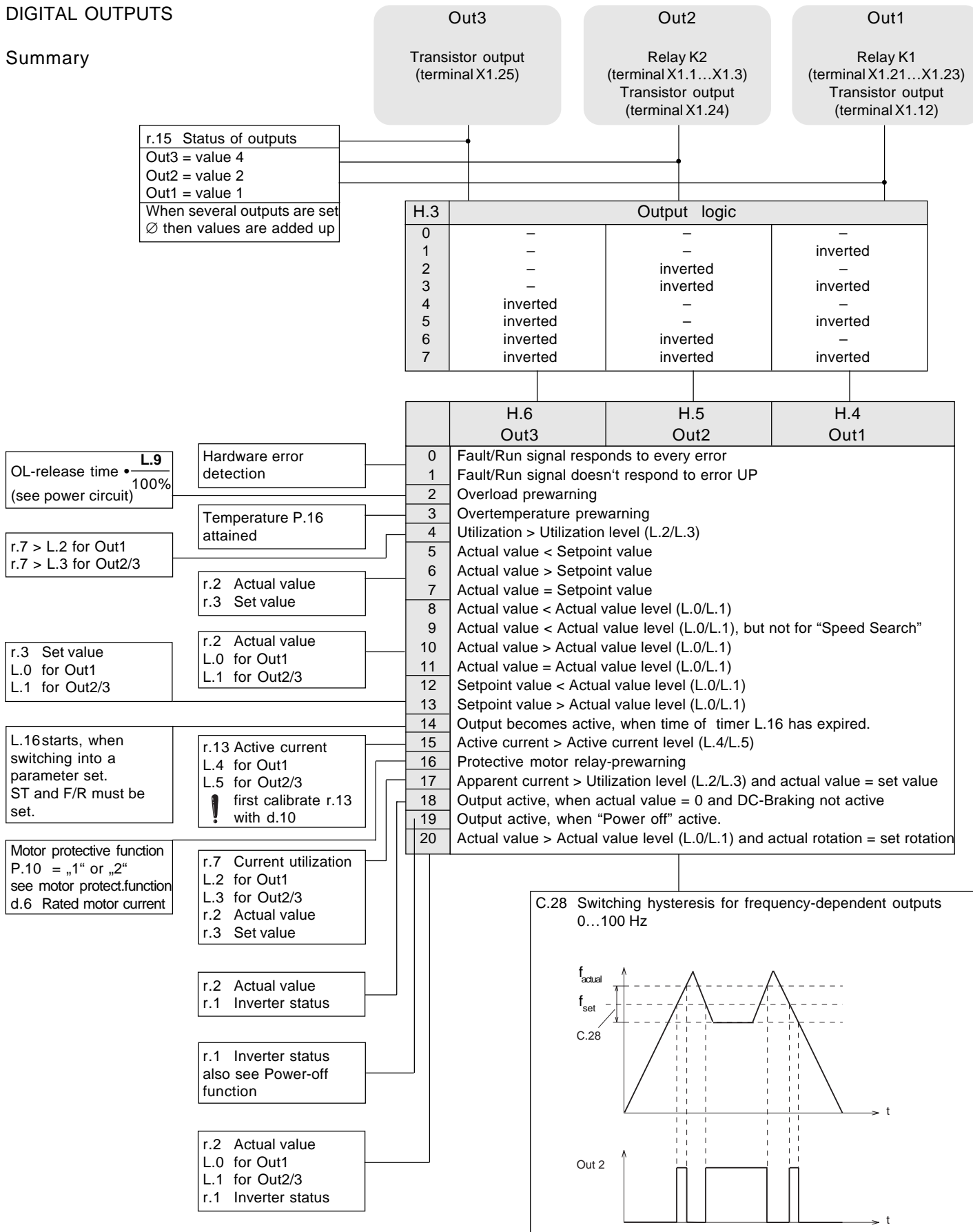

## Functional description

- The switching conditions for Out1...Out3 are specified with H.4, H.5 and H.6.
- The level or values belonging to it specify the point of switching.
- C.28 specifies for all frequency-dependent switching conditions a hysteresis above or below the switching point. It is effective on reaching the switching point.
- The outputs can be inverted with H.3.
- r.15 indicates which outputs are actuated. An inverted output is indicated as actuated output, if the switching condition are not met.

## Used Parameters

Parameter	Address	Value range	Correcting range	Resolution	Factory setting	Standard	Flags	Remarks
r.2	0202h	0...32767	0...409,58	0,0125 Hz	—	—	R, L0	depends on user-definit.
r.3	0203h	0...32767	0...409,58	0,0125 Hz	—	—	R, L0	depends on user-definit.
r.7	0207h	0...200	0...200	1 %	—	—	R, L0	—
r.12	020Ch	0...9999	0...999,9	0,1 A	—	—	R, L0	—
r.13	020Dh	0...9999	0...999,9	0,1 A	—	—	R, L0	—
r.15	020Fh	0...7	0...7	1	—	—	R, L0	—
P.10	040Ah	0...4	0...4	1	0	0	P, L3	—
P.16	0410h	0...100	0...100	1 °C	70 °C	70 °C	P, L3	—
H.3	0B03h	0...7	0...7	1	0	0	P, E, L3	—
H.4	0B04h	0...20	0...20	1	0	0	P, E, L3	—
H.5	0B05h	0...20	0...20	1	7	0	P, E, L3	—
H.6	0B06h	0...20	0...20	1	2	0	P, E, L3	—
L.0	0D00h	0...32767	0...409,58	0,0125 Hz	0 Hz	0 Hz	P, L3	depends on user-definit.
L.1	0D01h	0...32767	0...409,58	0,0125 Hz	4,0 Hz	4,0 Hz	P, L3	depends on user-definit.
L.2	0D02h	0...200	0...200	1 %	50 %	50 %	P, L3	—
L.3	0D03h	0...200	0...200	1 %	100 %	100 %	P, L3	—
L.4	0D04h	0...9999	0...999,9	0,1 A	0 A	0 A	P, L3	—
L.5	0D05h	0...9999	0...999,9	0,1 A	0 A	0 A	P, L3	—
L.9	0D09h	0...100	0...100	1 %	66 %	100 %	P, L3	—
L.16	0D10h	0...32766	0...327,66	0,01 s	0 s	0 s	P, L3	—
C.28	071Ch	0...8000	0...100,0	0,0125 Hz	0,5 Hz	0,5 Hz	P, L3	depends on user-definit.

(P = programmable Parameter L0 = no Password L3 = Customer Password R = Read-only-Parameter E = Enter Parameter)

## ANALOG OUTPUT

### Functional description

- Depending on switch S2 a voltage or current can be put out at terminal X1.15.
- The characteristic can be shifted in x-direction with H.18.
- The characteristic can be shifted in y-direction with H.10.
- H.11 defines the rise (gain) of the characteristic.
- Negative gains are also possible.
- H.9 defines which signal is switched to the analog output.

Analogue output  
(terminal X1.15)  
0...10 V or 0...20 mA  
switchable with S2

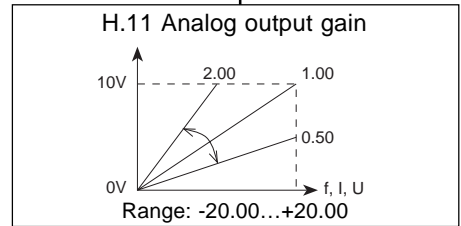
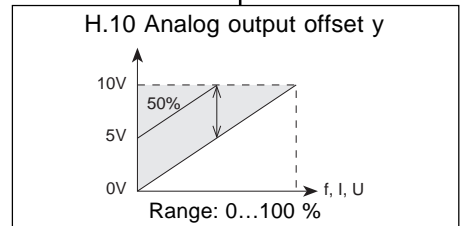
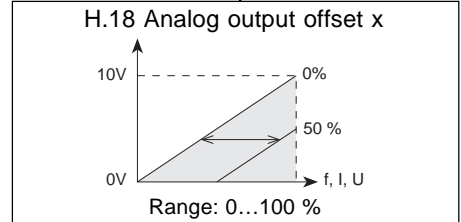

H.9 Analogue output function	
r.2	0 Actual value
r.7	1 Utilization
r.3	2 Setpoint value
r.4	3 Output voltage
r.5	4 Intermediate circuit voltage
r.13	5 Active current

### Used Parameters

Parameter	Address	Value range	Correcting range	Resolution	Factory setting	Standard	Flags	Remarks
r.2	0202h	0...32767	0...409,58	0,0125 Hz	—	—	R, L0	depends on user-definit.
r.3	0203h	0...32767	0...409,58	0,0125 Hz	—	—	R, L0	depends on user-definit.
r.4	0204h	0...999	0...999	1 V	—	—	R, L0	—
r.5	0205h	200...999	200...999	1 V	-	—	R, L0	—
r.7	0207h	0...200	0...200	1 %	—	—	R, L0	—
r.13	020Dh	0...9999	0...999,9	0,1 A	—	—	R, L0	—
H.9	0B09h	0...5	0...5	1	0	0	P, E, L3	—
H.10	0B0Ah	0...100	0...100	1 %	0 %	0 %	P, L3	—
H.11	0B0Bh	-2000...2000	-20,00...20,00	0,01	1,00	1,00	P, L3	—
H.18	0B12h	0...100	0...100	1 %	0 %	0 %	P, L3	—

P = programmable Parameter L0 = no Password L3 = Customer Password R = Read-only-Parameter E = Enter Parameter



## Adjustment

You can enter your own characteristic in the following diagram. Please proceed as follows:

- Define a characteristic point (A), standard (0.0).
- Define a characteristic point (B) through which your characteristic curve shall run.
- Draw a straight line through both points up to the range limits (see example characteristic).
- Adjust H.10 and H.18 to point A. (In the example H.10 = 20 %, H.18 = 30 %)
- Adjust the output signal to point B.
- Adjust the analog signal  $U_{out}$  ( $I_{out}$ ) with H.11 to the voltage (current) belonging to point B.
- Recheck the adjustment in point A, if necessary, readjust.

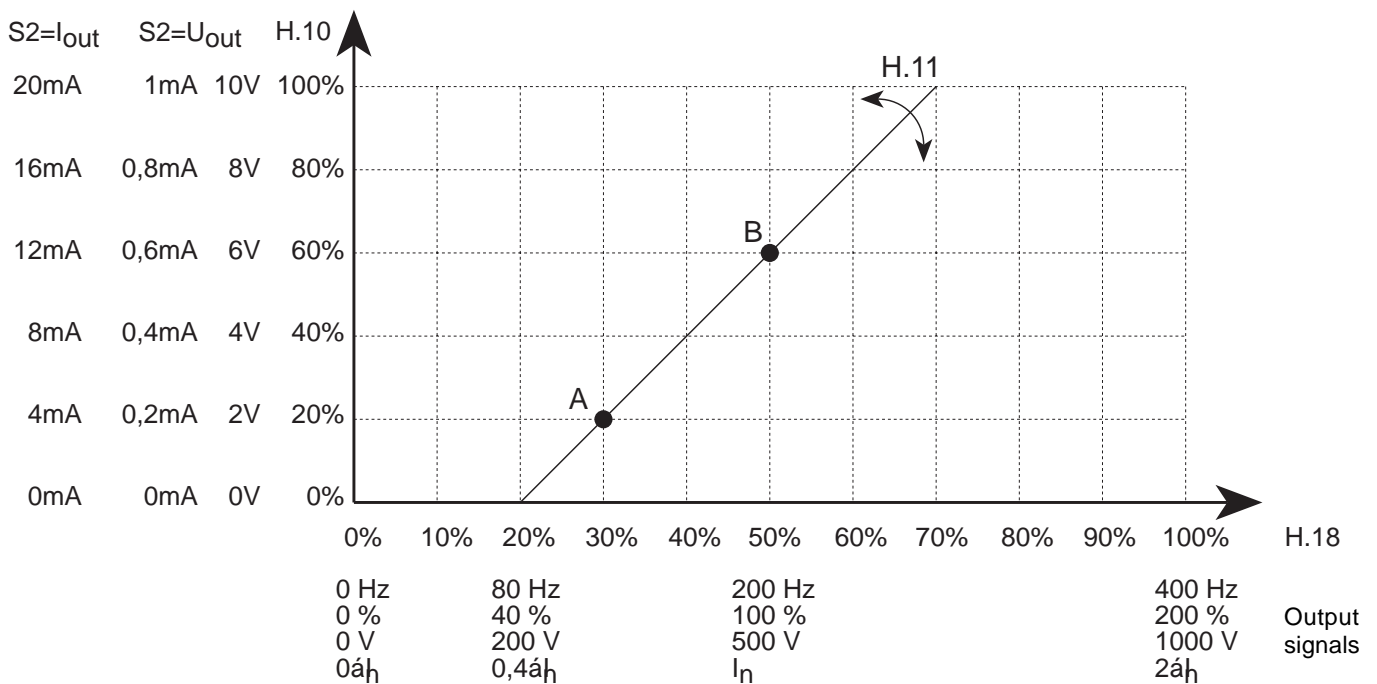

To simplify matters the frequency values have been rounded off.

A few setting examples:

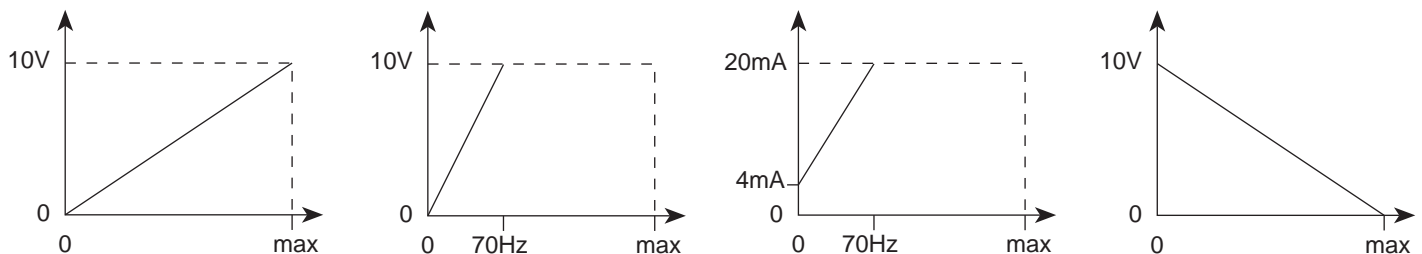

### Standard

H.10 = 0 %  
H.11 = 1  
H.18 = 0 %

H.10 = 0 %  
H.11 = 5,7  
H.18 = 0 %

H.10 = 20 %  
H.11 = 4,6  
H.18 = 0 %

H.10 = 100 %  
H.11 = -1  
H.18 = 0 %

# Special Settings

## PROGRAMMABLE INPUTS

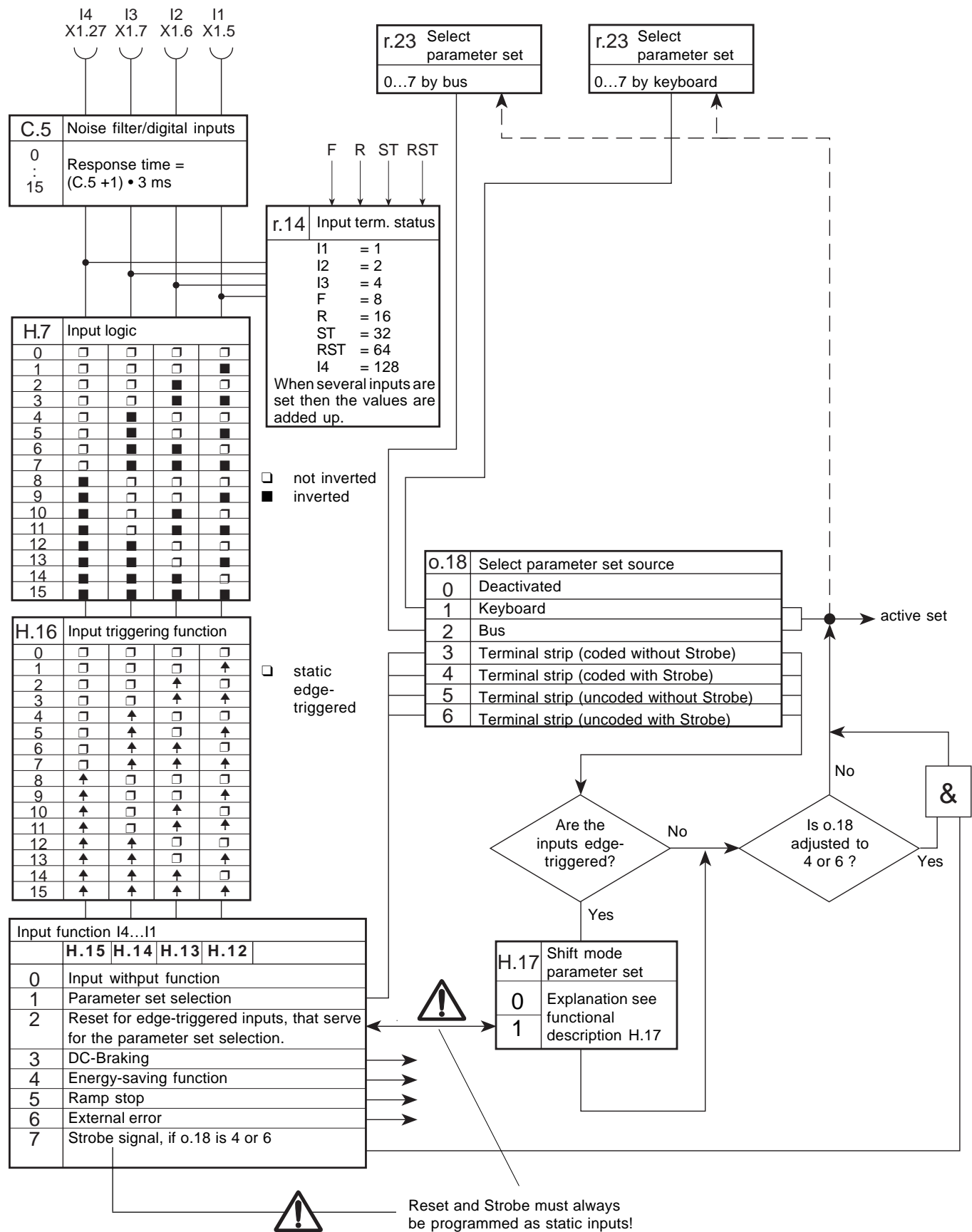

Functional description

After the hardware-type input wiring (NPN/PNP activation) the inputs I1...I4 as well as F, R, ST and RST run through

- the noise filter C.5. For a signal to be accepted none of the inputs may change its status during the response time.
- r.14 indicates the sum of the set inputs.
- The inputs can be inverted with H.7. For example, if H.16 is set to edge-triggered inputs, it is possible to trigger to the falling edge instead to the rising edge.
- With H.12, H.13, H.14 and H.15 the respective function of the input belonging to it is defined. The necessary occupancy for parameter set selection is affected by o.18 and H.17. Please observe Table 1.
- o.18 specifies the source, how the parameter set selection shall be carried out.  
 Coded means, the used inputs are binary-coded in ascending order.  
 With 4 inputs  $I1 = 2^0 = 1$  or with 2 inputs  $I1 = 2^0 = 1$   
 $I2 = 2^1 = 2$  (e.g. I1 and I3)  $I3 = 2^1 = 2$   
 $I3 = 2^2 = 4$   
 $I4 = 2^3 = 8$   
 Uncoded means, the used inputs activate in ascending order a parameter set, e.g.  
 $I1 = \text{Set 1}$  or  $I1 = \text{Set 1}$   
 $I2 = \text{Set 2}$   $I3 = \text{Set 2}$   
 $I3 = \text{Set 3}$   
 $I4 = \text{Set 4}$   
 If several uncoded inputs are activated simultaneously, the low-order input has always priority.  
 Strobe means, the parameter sets are not activated until the strobe signal is applied. It is mainly used for the activation of edge-triggered inputs.
- H.17 specifies the mode of parameter set shifting for edge-triggered inputs (see page E46).  
 $H.17 = 0$  1. edge sets input  
 2. edge sets input back  
 $H.17 = 1$  1. edge sets input  
 Resetting with another input  
 Set 0 with reset
- r.23 always indicates the active set.

Table 1

Occupancy for edge-triggered inputs			
o.18	H.17	possible inputs	possible parameter sets
3	0	3/1 free	0...7
3	1	3/1 Reset	0...7
4	0	3/1 Strobe	0...7
4	1	2/1 Reset/1 Strobe	0...7
5	0	4	0...4
5	1	3/ 1Reset	0...3
6	0	3/1 Strobe	0...3
6	1	2/1 Reset/1 Strobe	0...2

Table 2

Occupancy for static inputs		
o.18	possible inputs	possible parameter sets
3	3/1 free	0...7
4	3/1 Strobe	0...7
5	4	0...4
6	3/1 Strobe	0...3

## Special Settings

### Used Parameters

Parameter	Address	Value range	Correcting range	Resolution	Factory setting	Standard	Flags	Remarks
r.14	020EH	0...255	0...255	1	—	—	R, L0	—
r.23	0217H	0...F.03	0...7	1	0	0	E, L0	depends on o.18
o.18	0312H	0...6	0...6	1	3	0	E, L3	—
H.7	0B07H	0...15	0...15	1	0	0	E, L3	—
H.12	0B0CH	0...7	0...7	1	1	0	E, L3	—
H.13	0B0DH	0...7	0...7	1	1	0	E, L3	—
H.14	0B0EH	0...7	0...7	1	3	0	E, L3	—
H.15	0B0FH	0...7	0...7	1	5	0	E, L3	—
H.16	0B10H	0...15	0...15	1	0	0	E, L3	—
H.17	0B11H	0...1	0...1	1	1	1	L3	—
C.5	0705H	0...15	0...15	1	0	0	L3	—

P = programmable Parameter    L0 = no Password    L3 = Customer Password    R = Read-only-Parameter    E = Enter Parameter

## DC-BRAKING

With DC-braking the motor is not decelerated over a ramp. The fast braking is done with a dc-voltage, that is applied to the motor winding.

Between activation and triggering of the DC-braking a time constant called Base-Block-Time (bbL) of 150...1500 ms (dependent on the motor size) is required. It serves for the protection of the power modules the motor de-excitation time.

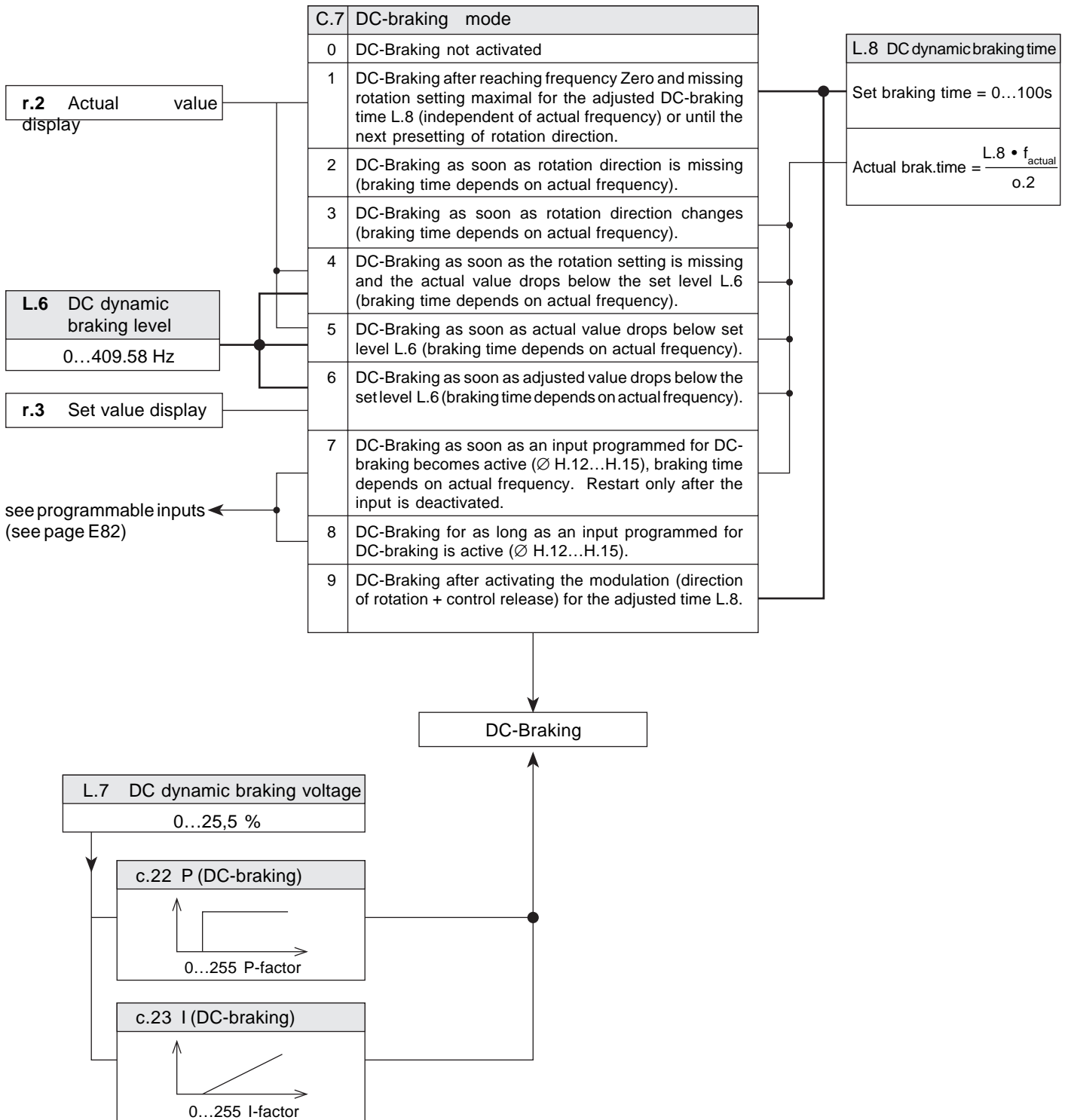

## Adjustment and optimization of DC-Braking

Ex factory the DC-braking is preset for standard three-phase asynchronous motors. If special motors (e.g. medium-frequency motors) are connected or if problems occur during DC-braking (e.g. OC error) an adjustment should be carried out. The adjustment of the control parameters c.22 and c.23 require an oscilloscope.

### Preparation

- Switch off the frequency inverter.
- Connect the oscilloscope to the analog output (terminal X1.15, X1.18).
- Switch on the unit again.
- Adjust:
  - Parameter H.9 to "1" (load at the analog output)
  - Parameter C.7 to "7", (DC-Braking on activation of a programmed input)
  - L.7 = 25,5%, L.8 = 10s With max. 25,5 % voltage for 10 s.
  - Parameter H.15 to "3" (I4 triggers DC-Braking)
- Now drive with maximum centrifugal mass to the maximum reference value of your application.
- Trigger DC-Braking with I4 and watch the oscilloscope.

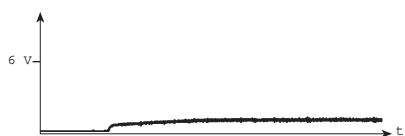

Control parameters c.22 and c.23 are limited with L.7. Consequently the output voltage is low.  
 ∅ Adjust L.7 to maximum value.



Control parameters c.22 and c.23 are adjusted too low. As a result only moderate response of DC-Braking.



P-component too large.  
 ∅ Reduce c.22.

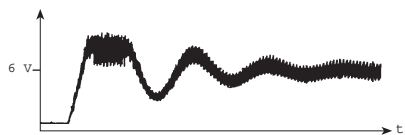

I-component too large.  
 ∅ Reduce c.23.



Correctly adjusted DC-Braking. Quick response but no overshooting.  
 Finally adjust the braking time with L.8 so that the motor comes safely to a standstill.

### Used Parameters

Parameter	Address	Value range	Correcting range	Resolution	Factory setting	Standard	Flags	Remarks
r.2	0202h	0...32767	0...409.58	0,0125 Hz	—	—	R, L0	depends on user-definit.
r.3	0203h	0...32767	0...409.58	0,0125 Hz	—	—	R, L0	depends on user-definit.
L.6	0D06h	0...32767	0...409.58	0,0125 Hz	0	0	P, L3	depends on user-definit.
L.7	0D07h	0...255	0...255	0,1 %	25,5 %	10 %	P, L3	—
L.8	0D08h	0...2000	0...100	0,05 s	10 s	0,1 s	P, L3	—
C.7	070h	0...9	0...9	1	7	0	P, E, L3	—
c.22	0916h	0...255	0...255	1	12	12	L3	—
c.23	0917h	0...255	0...255	1	6	6	L3	—

P = programmable Parameter    L0 = no Password    L3 = Customer Password    R = Read-only-Parameter    E = Enter Parameter

## RAMP STOP (LAD-STOP)

Ramp stop can be activated through three conditions:

- a) the LA-Stop function (acceleration)
- b) the LD-Stop function (deceleration)
- c) programmable inputs (refer to programmable inputs, see page E82))

### a) LA-Stop

This function protects the inverter against switch off caused by overcurrent during the acceleration phase. The current level is adjustable with P.3 in the range of 10...199 %. The protective function can be disabled with P.13.

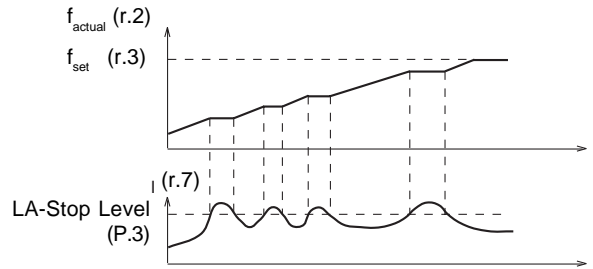

### b) LD-Stop

During deceleration energy is refed into the inverter which causes a rise of the intermediate circuit voltage.

If too much energy is refed the inverter can trip to error OP or OC. If the LD-Stop function has been activated with P.13, then the DEC ramp is regulated according to the adjusted intermediate circuit voltage (P.14) or the intermediate circuit current (P.3) in such a manner that errors are largely avoided.

## Summary

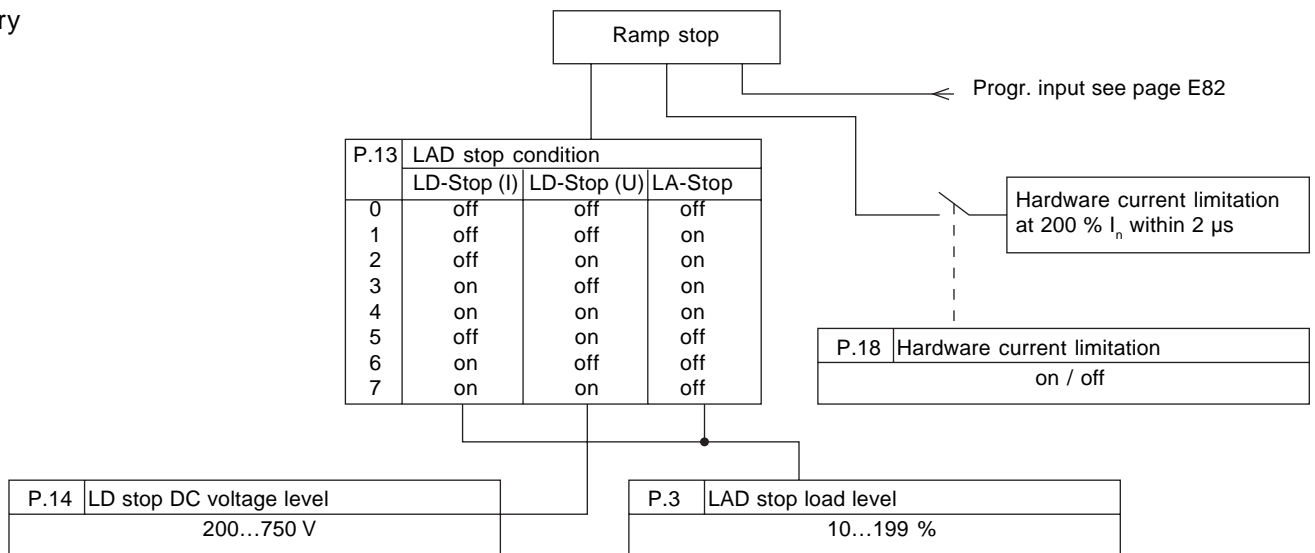

## Used Parameters

Parameter	Address	Value range	Correcting range	Resolution	Factory setting	Standard	Flags	Remarks
P.3	0403h	10...199	10...199	1 %	120 %	120 %	P, L3	—
P.13	040Dh	0...7	0...7	1	1	1	P, L3	—
P.14	040Eh	200...800	200...800	1 V	375V (720V)	375V (720V)	P, L3	200V-Class (400V-Class)
P.18	0412h	0...1	off...on	1	on	on	L3	—

P = programmable Parameter L0 = no Password L3 = Customer Password R = Read-only-Parameter E = Enter Parameter

# Special Settings

## CURRENT LIMIT (STALL-FUNCTION)

The Stall-function protects the frequency inverter against failures due to overcurrent at constant output frequency ( $f_{actual} = f_{set}$ ). It is activated with P.0 and adjustable in the range of 10...150 % of the rated inverter current.

If P.0 is adjusted to "oFF" the function is disabled. On attaining the adjusted load limit the frequency is increased/decreased with  $\Delta f/\Delta t$ , adjusted in P.1 and P.17, until falling below the load limit. The process is dependent on the stall-characteristic (P.2). The frequency remains at this value or is increased/decreased if the load falls below the adjusted stall limit.

### Summary

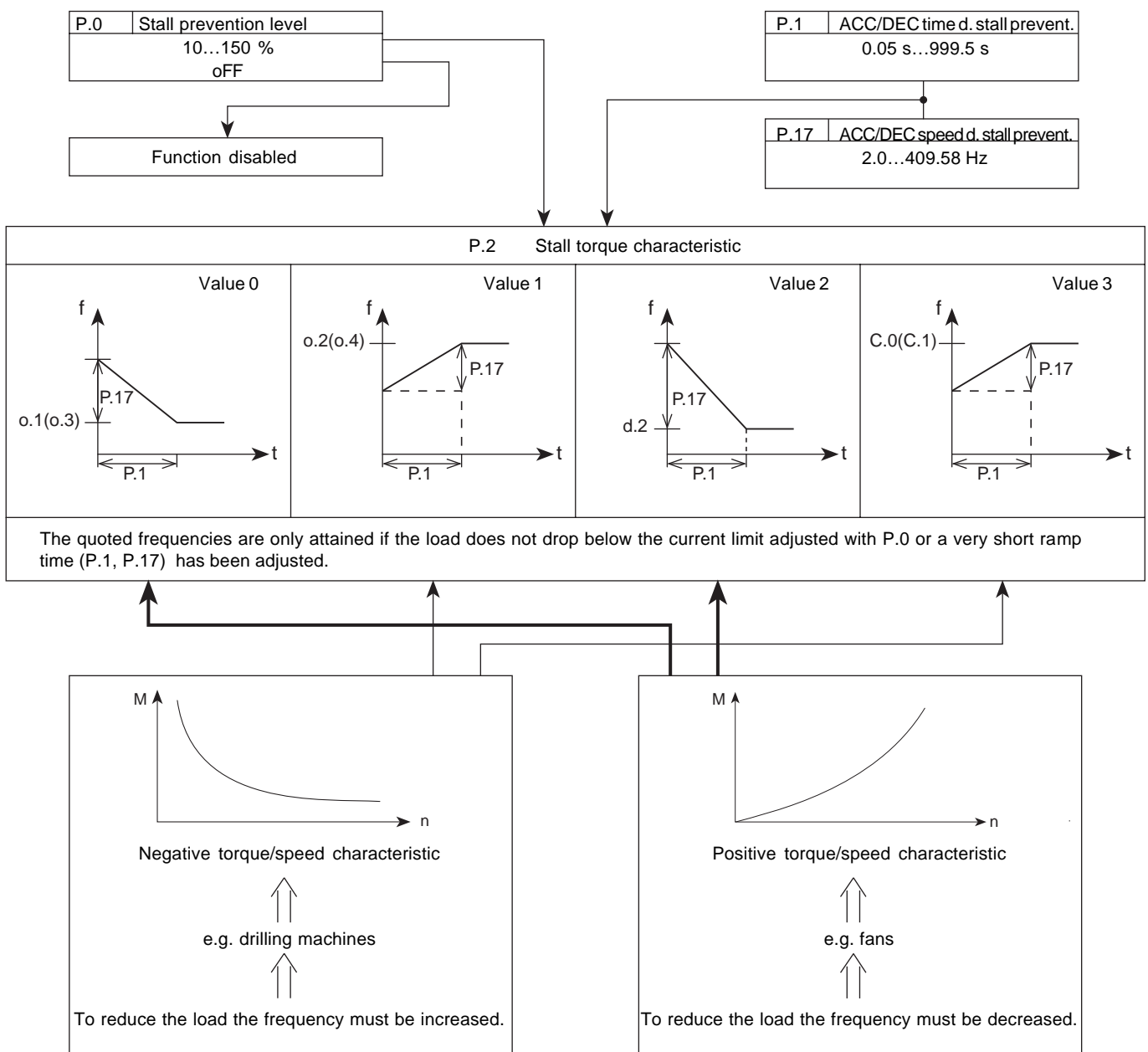



Example with positive torque/speed characteristic

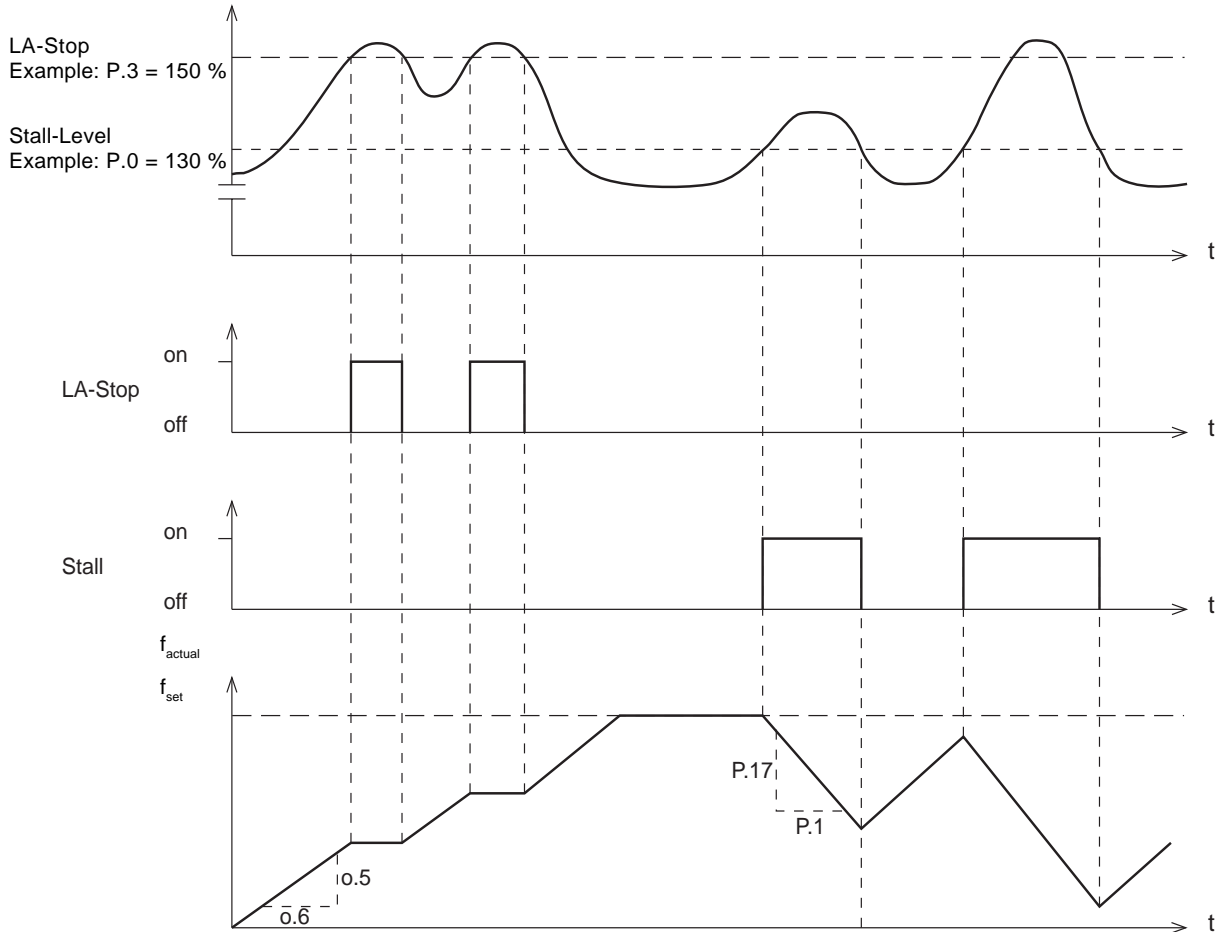

## Used Parameters

Parameter	Address	Value range	Correcting range	Resolution	Factory setting	Standard	Flags	Remarks
o.1	0301h	0...32767	0...o.2	0,0125 Hz	0 Hz	0 Hz	P, L3	depends on user-definit.
o.2	0302h	0...32767	o.1...409.58	0,0125 Hz	70 Hz	70 Hz	P, L3	depends on user-definit.
o.3	0303h	0...32767	0...o.4	0,0125 Hz	0 Hz	0 Hz	P, L3	depends on user-definit.
o.4	0304h	0...32767	o.3...409.58	0,0125 Hz	70 Hz	70 Hz	P, L3	depends on user-definit.
P.0	0400h	10...151	10...150, off	1 %	150 %	150 %	P, L3	—
P.1	0401h	1...19990	0.05...999.50	0,05 s	1 s	1 s	P, L3	—
P.2	0402h	0...3	0...3	1	0	0	P, E, L3	—
P.17	0411h	160...32767	2.0...409.58	0,0125 Hz	70 Hz	70 Hz	P, L3	depends on user-definit.
d.2	0502h	0...4080	0...51.0	0,0125 Hz	0 Hz	0 Hz	P, L3	depends on user-definit.
C.0	0700h	0...32767	0...409.58	0,0125 Hz	409,58 Hz	409,58 Hz	P, L3	depends on user-definit.
C.1	0701h	0...32767	0...409.58	0,0125 Hz	409,58 Hz	409,58 Hz	P, L3	depends on user-definit.

P = programmable Parameter L0 = no Password L3 = Customer Password R = Read-only-Parameter E = Enter Parameter

### SPEED SEARCH AND AUTOMATIC RETRY

Automatic retry can take place on three different conditions:

- a) If after a short-time power failure the UP error shall be automatically reset the automatic retry UP must be enabled. With Parameter P.7 the number of automatic retries after UP error can be limited from 1...10 within 10 minutes. P.7 = 11 means that an unlimited number of resetting UP errors is possible.



If the supply voltage returns after the display indication goes out (depending on the load after ca. 2-5 s), the inverter starts with a cold start. Provide protective measures for the machine personnel!

- b) In case of OC errors the number (max. 5) of automatic retries within 10 minutes can be specified in P.8. For the protection of the power modules a hold-off interval of 15 s elapses after each OC error.
- c) In case of OP error the number (max. 10) of automatic retries within 10 minutes can be specified in P.9. For the protection of the power modules a hold-off interval of 15 s elapses after each OP error.

If the maximum number of errors within 10 minutes is exceeded, the only way to reset the error is with Reset (terminal X1.20) or cold start.

Speed search is activated by the conditions adjusted in P.6. The search takes place with the mode adjusted in P.20! The higher the adjusted value in P.20, the faster works the function.

At activated speed search the inverter searches for the actual motor speed, adapts its output frequency and accelerates with the adjusted ramp to the setpoint value. In case speed search is not activated the inverter immediately drives its adjusted acceleration ramp (ACC). The different rotating field frequencies of the coasting motor and the inverter may cause errors.

Observe following instructions for an unobjectionable function!

Conditions for the start of speed search (t1):

actual setpoint value	• old setpoint value	(safe)
actual setpoint value	• actual motor speed	(safe)
actual setpoint value	< actual motor speed	(critical)
actual rotation direction	= old rotation direction	(safe)
actual rotation direction	• old rotation direction	(critical)

## Summary

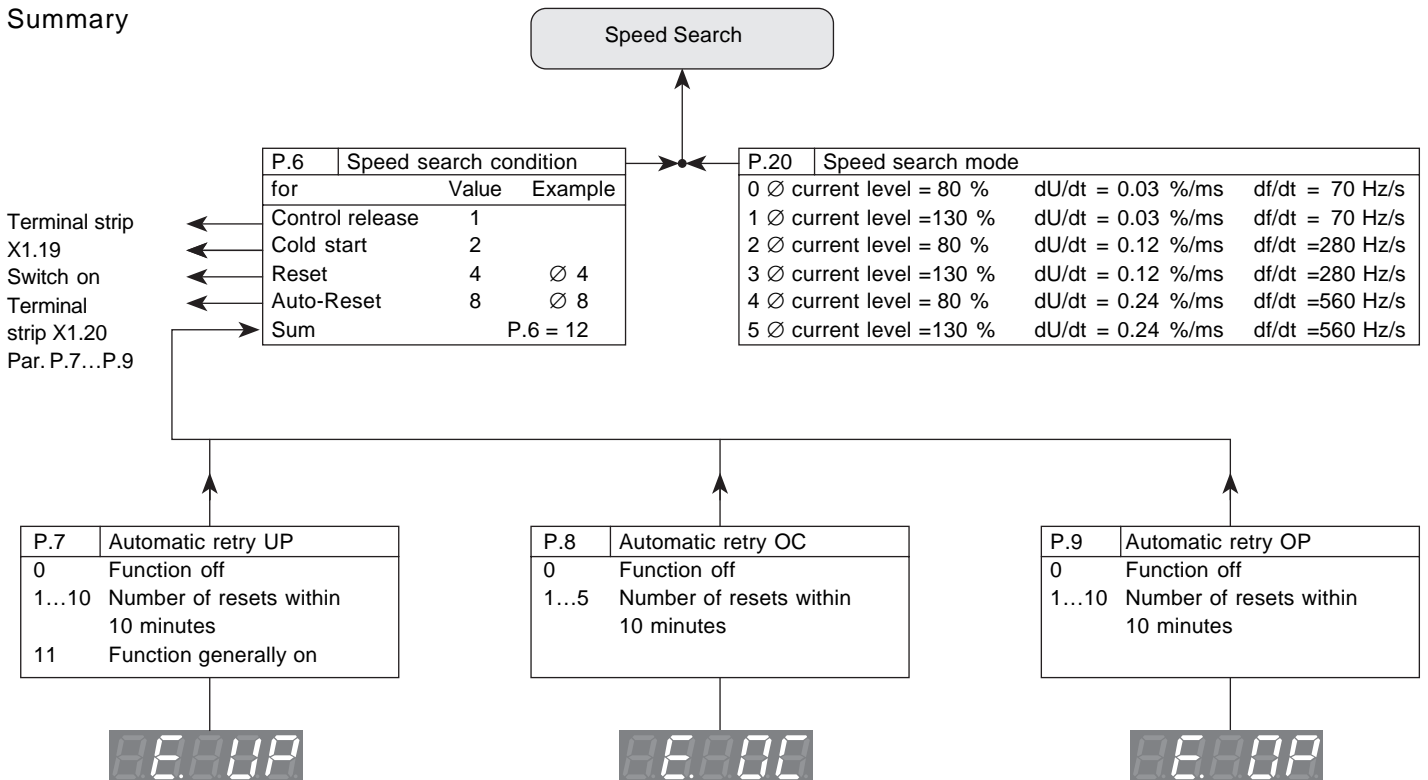

## Used Parameters

Parameter	Address	Value range	Correcting range	Resolution	Factory setting	Standard	Flags	Remarks
P.6	0406h	0...15	0...15	1	0	0	P, L3	—
P.7	0407h	0...11	0...11	1	0	0	P, L3	0 = off, 11 = generally on
P.8	0408h	0...5	0...5	1	0	0	P, L3	0 = off
P.9	0409h	0...10	0...10	1	0	0	P, L3	0 = off
P.20	0414h	0...5	0...5	1	0	0	P, L3	—

P = programmable Parameter    L0 = no Password    L3 = Customer Password    R = Read-only-Parameter    E = Enter Parameter

# Special Settings

## Motor protective function

The motor protective function protects the connected motor against thermal destruction caused by too high currents. The function corresponds in most points to mechanic motor protective components. In addition to it the influence of the motor speed on the cooling of the motor is taken into consideration. The motor load is calculated from the measured apparent current (r.12) and the rated motor current (d.6).

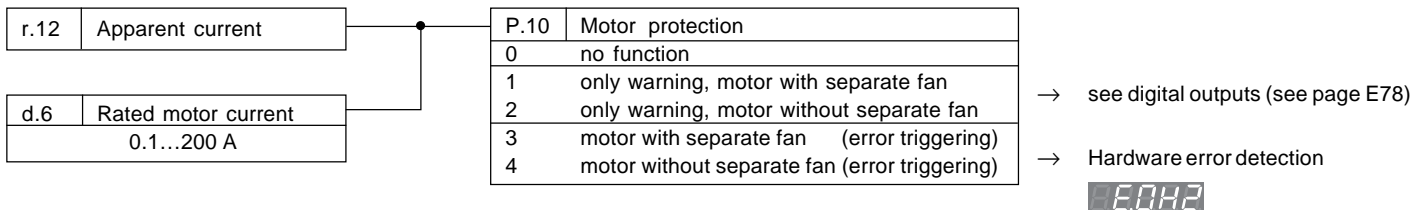

For forced-ventilated motors or at rated frequency of a self-ventilated motor the following release times (VDE 0660, Part 104) apply:

- 1,2 •  $I_n$  → 2 hours
- 1,5 •  $I_n$  → 2 minutes
- 2 •  $I_n$  → 1 minute
- 8 •  $I_n$  → 5 seconds

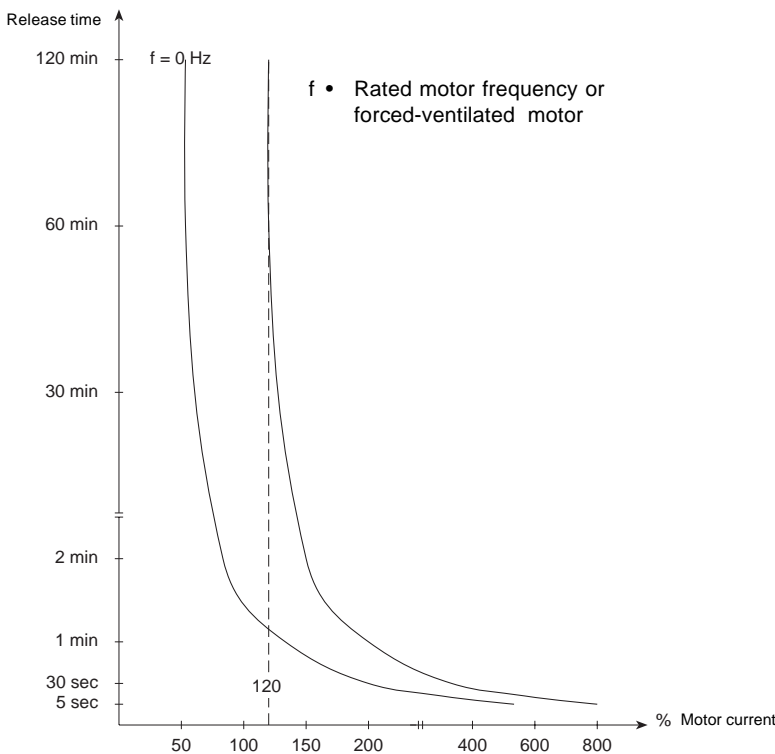

The release times reduces itself for self-ventilated motors with the frequency of the motor (see diagram).

The motor protective function acts integrating, i.e. times with overload on the motor are added, times with underload are subtracted.

After the motor protective function has been triggered the new release time is reduced to one quarter of the quoted values, provided that the motor has not been operated for an appropriate time with underload.

## Used Parameters

Parameter	Address	Value range	Correcting range	Resolution	Factory setting	Standard	Flags	Remarks
r.12	020Ch	0...9999	0...999	0,1 A	—	—	P, L0	—
P.10	040Ah	0...4	0...4	1	0	0	P, L1	—
d.6	0506h	1...2000	0,1...200 A	0,1 A	30 A	30 A	P, L1	—

P = programmable Parameter    L0 = no Password    L3 = Customer Password    R = Read-only-Parameter    E = Enter Parameter

## ENERGY-SAVING FUNCTION

The energy saving function permits a reduction or increase of the actual output voltage. In conformity with the conditions defined in P.11 the voltage according to the V/Hz characteristic is changed in percent by P.12.

Even at a value of > 100 % the maximum output voltage cannot be higher than the input voltage. For example, the function is used for cyclic operating load/no-load applications. During the no-load phase the speed is maintained, but by reducing the voltage energy is saved.

## Summary

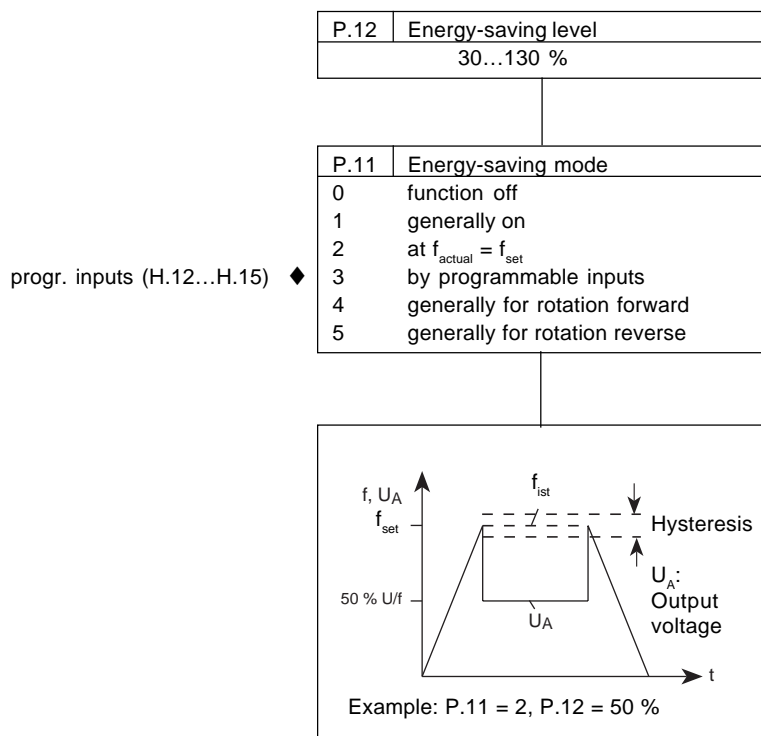

## Used Parameters

Parameter	Address	Value range	Correcting range	Resolution	Factory setting	Standard	Flags	Remarks
P.11	040Bh	0...5	0...5	1	0	0	P, E, L3	—
P.12	040Ch	30...130	30...130	1 %	100 %	100 %	P, L3	—

P = programmable Parameter    L0 = no Password    L3 = Customer Password    R = Read-only-Parameter    E = Enter Parameter

## AUTOBOOST AND SLIP COMPENSATION

In case of high load torques the autoboot causes an automatic I•R compensation by increasing the output voltage; the magnetizing current remains constant.

The slip compensation equalizes the load fluctuations caused by changing speed.

The combination of the two functions contributes to the improvement of the performance (constant speed, high breakdown torque) over the entire speed range.

### Adjustment of motor data

1. Take the following data from the name plate of your motor.

Typ depends on manufacturer		
Phasen 3 ~		IP54
$\Delta$ 220/380V	V	6,4 / 3,7 A
1,5	kW	S 1
2,0	PS	cos $\varphi$ 0,80
1410	1/min	50 Hz

d.6	Rated motor current	0,1...200,0 A	Standard 30,0 A
d.8	Rated motor cos $\varphi$	0,05...1,00	Standard 0,83
d.7	Rated motor frequency	20,0...3000,0 Hz	Standard 50 Hz
d.5	Rated motor speed	100...25000 rpm	Standard 1460 rpm

2. Independent to the motor wiring (Y,  $\Delta$ ), the motor resistance is being measured at a warm motor between 2 phases of the motor supply line. In this manner the ohmic line impedance is recorded at the same time (important for long supply lines!).

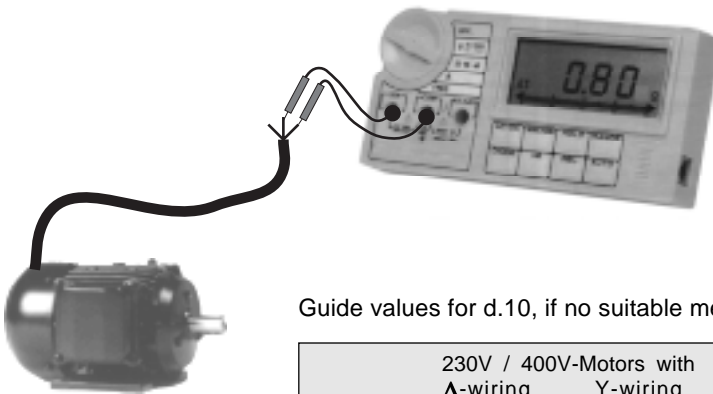

d.10	Motor terminal resistance	0,0...150 $\Omega$	Standard 0,60 $\Omega$
measured with m-ohmmeter between 2 phases at the motor line.			

Guide values for d.10, if no suitable measuring devices are available:

$P_R$ /kW	230V / 400V-Motors with		230V / 400V-Motors with Y-wiring	
	$\Delta$ -wiring	Y-wiring	400V / 690V-Motors with $\Delta$ -wiring	
	R/ $\Omega$ (d.10)	R/ $\Omega$ (d.10)	$P_R$ /kW	R/ $\Omega$ (d.10)
0,37	14,0	42,0	5,5	2,2
0,55	12,0	36,0	7,5	1,5
0,75	9,0	27,0	11,0	0,9
1,1	5,5	16,5	15,0	0,6
1,5	3,5	10,5	18,5	0,45
2,2	2,5	7,5	22,0	0,36
3,0	1,5	4,5	30,0	0,24
4,0	1,1	3,3	45,0	0,15
			55,0	0,12
			75,0	0,09

### Adjustment of regulator

3. Adjust d.18 (frequency gain) and d.19 (voltage gain) to the value "1.00", which usually provides sufficient compensation for standard motors.

4. Activate autoboot or slip compensation (incl. auto boost) with c.8.

c.8	Regulator selection	
	Slip compens.	Autoboot
0	off	off
1	off	on
2	on	on
3	on	on

d.18	Slip compensation/ frequency gain
0.00...2.55	Standard 1.00

d.19	Slip compensation/ auto torque gain
0.00...2.55	Standard 1.00

## Optimization of regulator

5. Measure the speed of the unloaded machine. Put load on the machine and measure the speed again. If necessary, adjust the parameters d.18 and d.19 to the desired speed/torque performance.
6. Take the load off the machine. Check, whether voltage and frequency return to unloaded condition.

- a) No frequency increase, speed decreases => no regulator activated or it is adjusted too low.
- b) Frequency is being increased, speed decreases => voltage increase is too low or none at all.
- c) No frequency increase, speed decreases => frequency increase is too low or none at all.
- d) Speed is maintained after a short adjustment phase => optimal setting.

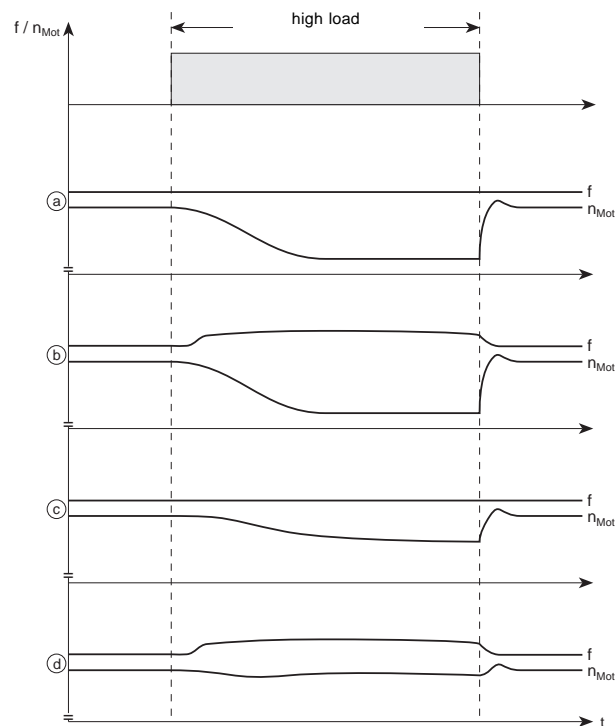

## Used Parameters

Parameter	Address	Value range	Correcting range	Resolution	Factory setting	Standard	Flags	Remarks
d.5	0505h	100...25000	0...25000	1 rpm	1470 rpm	1470 rpm	P, L3	—
d.6	0506h	1...2000	0.1...200.0	0.1 A	30.0 A	30.0 A	P, L3	—
d.7	0507h	2500...30000	20.0...3000	0.1 Hz	50 Hz	50 Hz	P, L3	—
d.8	0508h	50...100	0.50...1.00	0.01	0.86	0.86	P, L3	—
d.10	050Ah	0...15000	0...150.00	0.01 ý	0.60 ý	0.60 ý	P, L3	—
d.18	0512h	0...255	0...2.55	0.01	1.00	1.00	P, L3	—
d.19	0513h	0...255	0...2.55	0.01	1.00	1.00	P, L3	—
c.8	0908h	0...3	0...3	1	0	0	P, L3	—

P = programmable Parameter L0 = no Password L3 = Customer Password R = Read-only-Parameter E = Enter Parameter

## MODULATION

The modulation procedure as well as the carrier frequency of the power modules can be adapted to the requirements of the application.

### Modulation procedure

The D-control board permits the selection of 2 or 3-switch modulation. Ex factory the 3-switch modulation is adjusted. When changing to 2-switch modulation the following advantages respectively disadvantages in the range up to the corner frequency are to be considered:

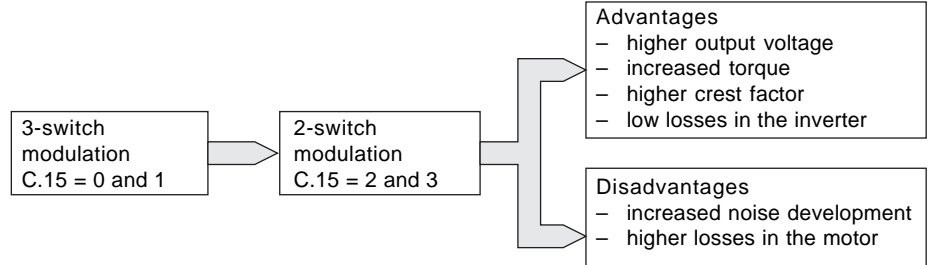

Regardless of whether 2 or 3-switch modulation is selected, an overmodulation occurs at the max. output voltage. This leads to an even higher output voltage and torque. The frequency at which overmodulation takes place depends on the adjusted U/f-characteristic and in particular on the output voltage stabilisation (C.10). The higher the adjustment of C.10, the earlier overmodulation occurs.



An improper adjustment of C.10 leads to overcurrent (OC) errors in the lower speed range or thermal overload of the motor.

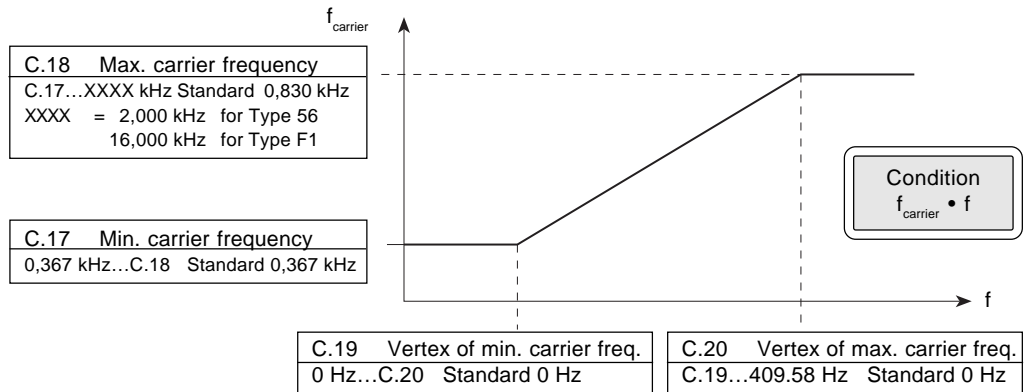

Advantages of the frequency-dependent carrier-frequency adaption:

- increased torque in the lower frequency range
- low losses in the inverter
- low current ripples at high output frequencies.



The carrier frequency must be adjusted clearly larger than the output frequency to avoid undefined pulse pattern and interferences!

### Used Parameters

Parameter	Address	Value range	Correcting range	Resolution	Factory setting	Standard	Flags	Remarks
C.10	070Ah	150...630	150...649, oFF	1 V	oFF	oFF	P, E, L3	—
C.15	070Fh	0...3	0...3	1	3	3	P, L3	—
C.17	0711h	367...2000(16000)	367...C.18	1 Hz	0,367 kHz	0,367 kHz	P, L3	( )only F1
C.18	0712h	367...2000(16000)	C.17...2000(16000)	1 Hz	0,830 kHz	0,830 kHz	P, L3	( )only F1
C.19	0713h	0...32767	0...C.20	0,0125 Hz	0 Hz	0 Hz	P, L3	depends on user-definit.
C.20	0714h	0...32767	C.19...409,58	0,0125 Hz	0 Hz	0 HZ	P, L3	depends on user-definit.

P = programmable Parameter L0 = no Password L3 = Customer Password R = Read-only-Parameter E = Enter Parameter



## SCALING OF DISPLAY

The standard indication of following parameters is in frequencies:

r.2	o.1	P.17	L.0	d.2	C.0	c.16
r.3	o.2		L.1		C.1	c.19
r.19	o.3		L.6		C.19	c.21
	o.4		L.10		C.20	
	o.5		L.11		C.22	
	o.7		L.12		C.28	
	o.9		L.13			
	o.11		L.14			
			L.15			

With parameters C.29...C.33 the display indication of the above listed parameters can be changed to other units (e.g. speed, delivery rate etc.).

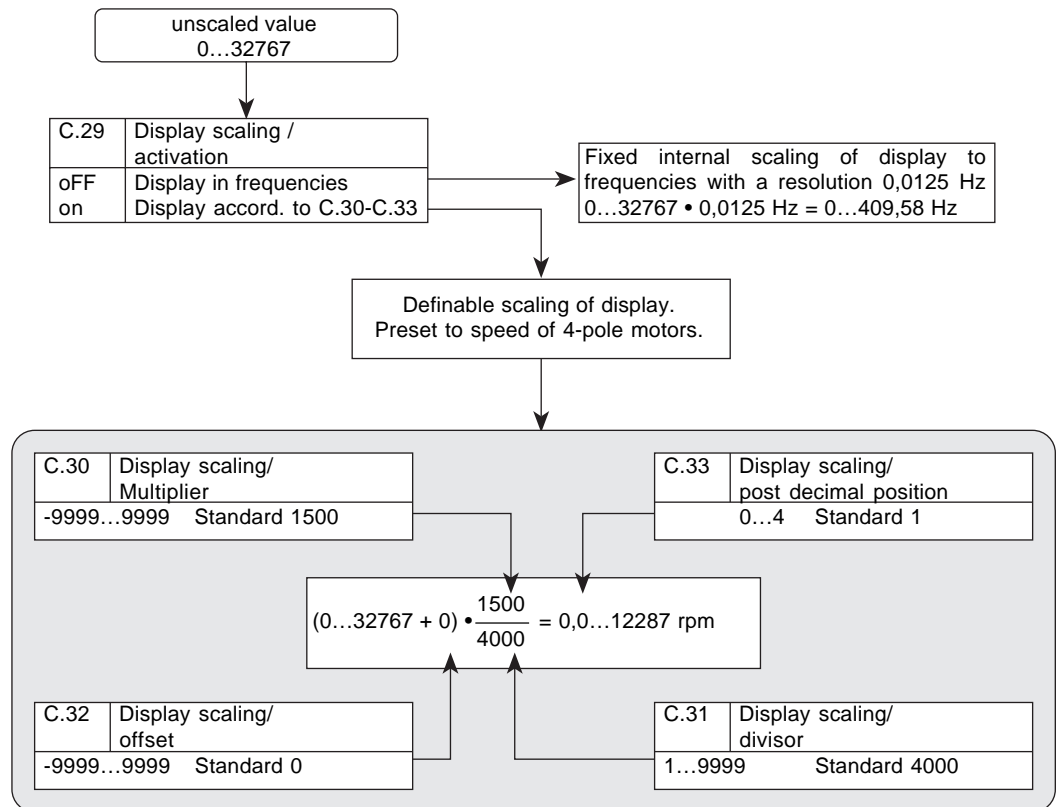

Values for speed in dependence on the number of poles of the motor

Number of poles	2	4	6	8	10	12
<b>C.30</b>	3000	1500	1000	750	600	500
<b>C.31</b>	4000	4000	4000	4000	4000	4000

# Special Settings

## Definition of own scaling

To define your own scaling enter in the diagram below

- a point A at the frequency, at which the display is still indicating "0" (in the example 10 Hz).
- a point B at the frequency, where a desired value is attained with the unit selected by you (in the example 50 Hz).

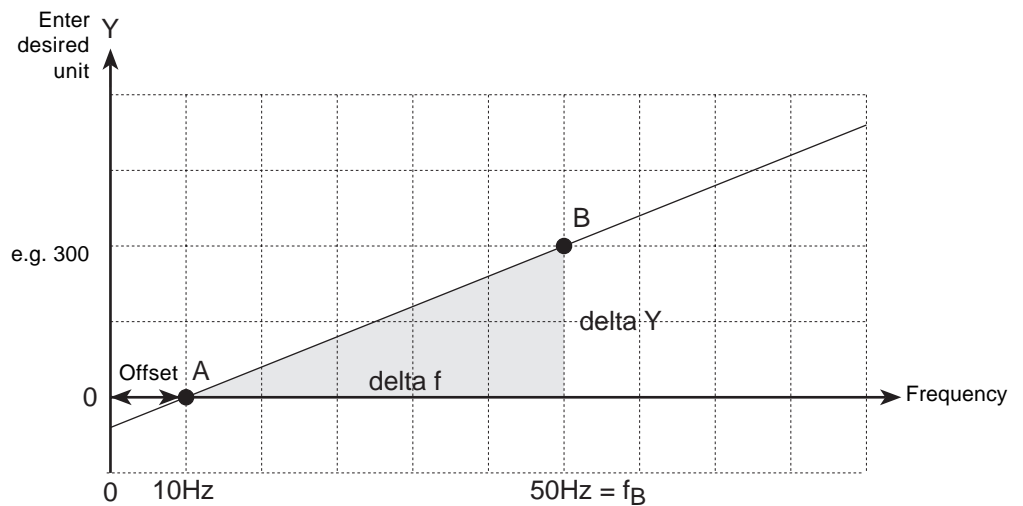

Determine  $\Delta f$  (in the example  $50 \text{ Hz} - 10 \text{ Hz} = 40 \text{ Hz}$ ) and  $\Delta Y$  (in the example  $300 - 0 = 300$ ).

## Calculation of C.30 and C.31

$$C.30 = \Delta Y = 300$$

$$C.31 = \frac{\Delta f}{0,0125 \text{ Hz}} = \frac{40 \text{ Hz}}{0,0125 \text{ Hz}} = 3200$$

$$\text{Desired scaling} = \frac{C.30}{C.31} = \frac{\Delta Y}{\text{unscaled value}} = \frac{300}{3200} \quad (\text{if necessary decrease})$$

## Adjustment of offset

$$\text{Offset C.32} = \frac{f_B - \Delta f}{0,0125 \text{ Hz}} = \frac{50 \text{ Hz} - 40 \text{ Hz}}{0,0125 \text{ Hz}} = 800$$



The adjusted scaling for the display indication is only applicable for the inverter. KEB COMBIVIS can be scaled independent of it.

## Used Parameters

Parameter	Address	Value range	Correcting range	Resolution	Factory setting	Standard	Flags	Remarks
C.29	071Dh	0...1	oFF/on	1	oFF	oFF	L3	—
C.30	071Eh	-9999...9999	-9999...9999	1	1500	1500	L3	—
C.31	071Fh	1...9999	1...9999	1	4000	4000	L3	—
C.32	0720h	-9999...9999	-9999...9999	1	0	0	L3	—
C.33	0721h	0...4	0...4	1	1	1	L3	—

P = programmable Parameter L0 = no Password L3 = Customer Password R = Read-only-Parameter E = Enter Parameter

## POWER-OFF FUNCTION



The function depends on the power circuit



D

### Mode of functioning

The Power-off function permits the controlled deceleration of the drive until standstill in case of undervoltage (e.g. due to power failure). Especially for parallel running drives (e.g. in textile machines) the uncontrolled coasting of the motor and the adverse consequences (e.g. thread breakage etc.) resulting from it are being avoided.

To use the Power-off function

- the switch position of F1 units must be adjusted to Power-off according to instruction manual KEB COMBIVERT F1/F2 Part 1!
- the third digit of the power circuit variant of type 56 must show a „D“ (see name plate) (Ø special version).

- Triggering through phase failure signal or when falling below a programmable  $U_{zk}$  level (Ø c.14).
- After triggering an abrupt frequency reduction takes place (Ø c.16), i.e. the motor falls into regenerative operation and feeds energy into the intermediate circuit.
- The intermediate circuit voltage of a PI-regulator is regulated to the adjusted level (Ø c.13).  
P-component Ø c.10  
I-component Ø c.11
- After approx. 200 ms the function is cancelled provided that during this time no phase failure signal has occurred.



At the time only the F-power circuits and the power circuits of type 56 sizes 19...23 support the phase failure signal for the Power-off function!  
All other 56-power circuits require an alteration of the wiring with regard to the error detection (Ø special versions).

### Further adjustments

Starting ramp (c.15, c.21)

Frequency-dependent amplification factor for starting ramp (c.17)

Load-dependent amplification factor for starting ramp (c.18)

The Power-off function is adjusted at any chosen working point of the machine (e.g. rated speed, small load) with parameter c.12 = 1 (setting mode). The actual frequency  $f_{BP}$  and the actual load  $I_{BP}$  of this working point are automatically stored by the inverter. For normal operation (c.12 = 2) the starting ramp is adapted in reference to the parameters c.17 and c.18 load- and frequency-dependent in all working points.

### Additional protective functions

During the execution of the Power-off function the ramp stop function (LD-Stop) is active independent of the adjustment in P.13 (LAD stop condition)!

If the level of the intermediate circuit voltage adjusted in P.14 or the load level adjusted in P.3 are exceeded, the deceleration ramp is disabled. This can lead to oscillations of the intermediate circuit voltage characteristic.

## Function chart Power-off function

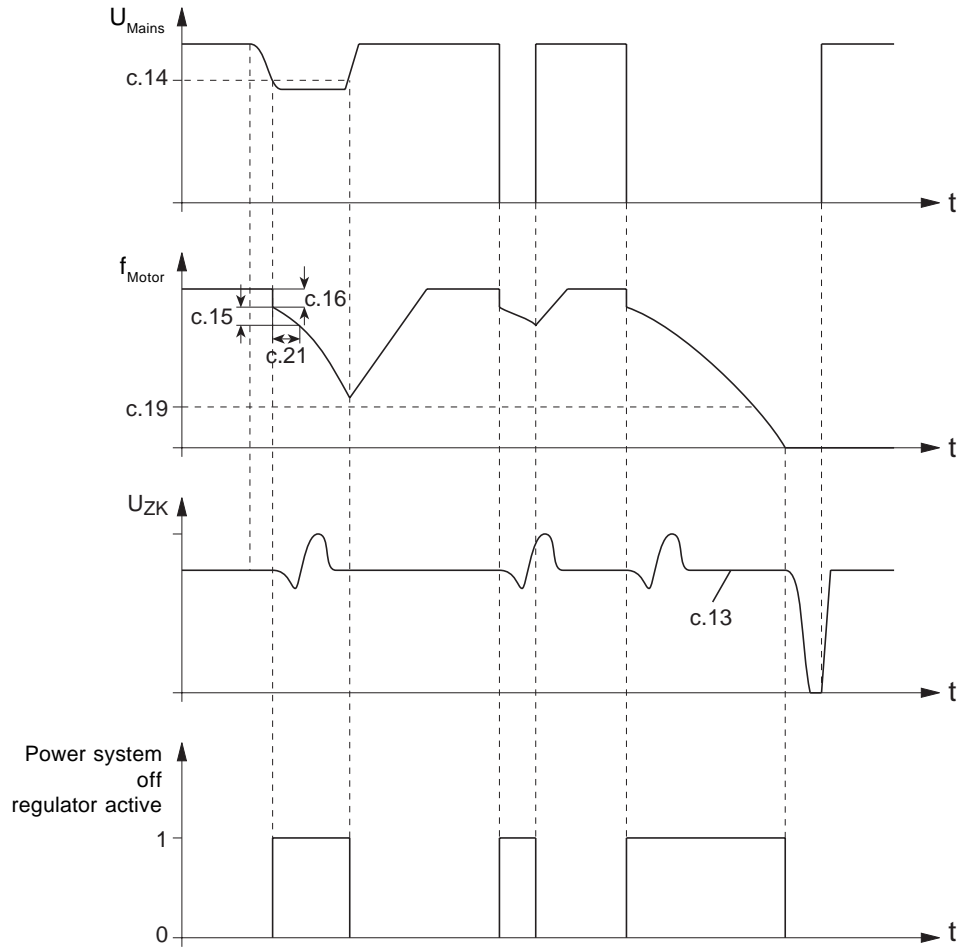

## Used Parameters

Parameter	Address	Value range	Correcting range	Resolution	Factory setting	Standard	Flags	Remarks
P.3	0403h	10...199	10...199	1 %	120 %	120 %	P, L3	—
P.14	040Eh	200...800	200...800	1 V	375V (720V)	375V (720V)	P, L3	200V (400V) Class
c.10	090Ah	0...255	0...255	1	0	0	L3	0 = off
c.11	090Bh	0...255	0...255	1	0	0	L3	0 = off
c.12	090Ch	0...2	0...2	1	0	0	L3	1=setting, 2=normal operation
c.13	090Dh	100...150	100...150	1 %	100 %	100 %	L3	—
c.14	090Eh	50...100	50...100	1 %	80 %	80 %	L3	—
c.15	090Fh	1...19990	0.05...999.5	0.05 s	41 s	41 s	L3	—
c.16	0910h	0...2000	0...25	0.0125 Hz	2 Hz	2 Hz	L3	depends on user-definition
c.17	0911h	0...4095	0...4095	1	0	0	L3	—
c.18	0912h	0...4095	0...4095	1	0	0	L3	—
c.19	0913h	0...32767	0...409.58	0.0125 Hz	0 Hz	0 Hz	L3	depends on user-definition
c.20	0914h	0...4095	0...4095	1	0	0	L3	—
c.21	0915h	0...32767	0...409.48	0.0125 Hz	70 Hz	70 Hz	L3	depends on user definition

P = programmable Parameter L0 = no Password L3 = Customer Password R = read-only-Parameter E = Enter Parameter

Adjustment of Power-off function

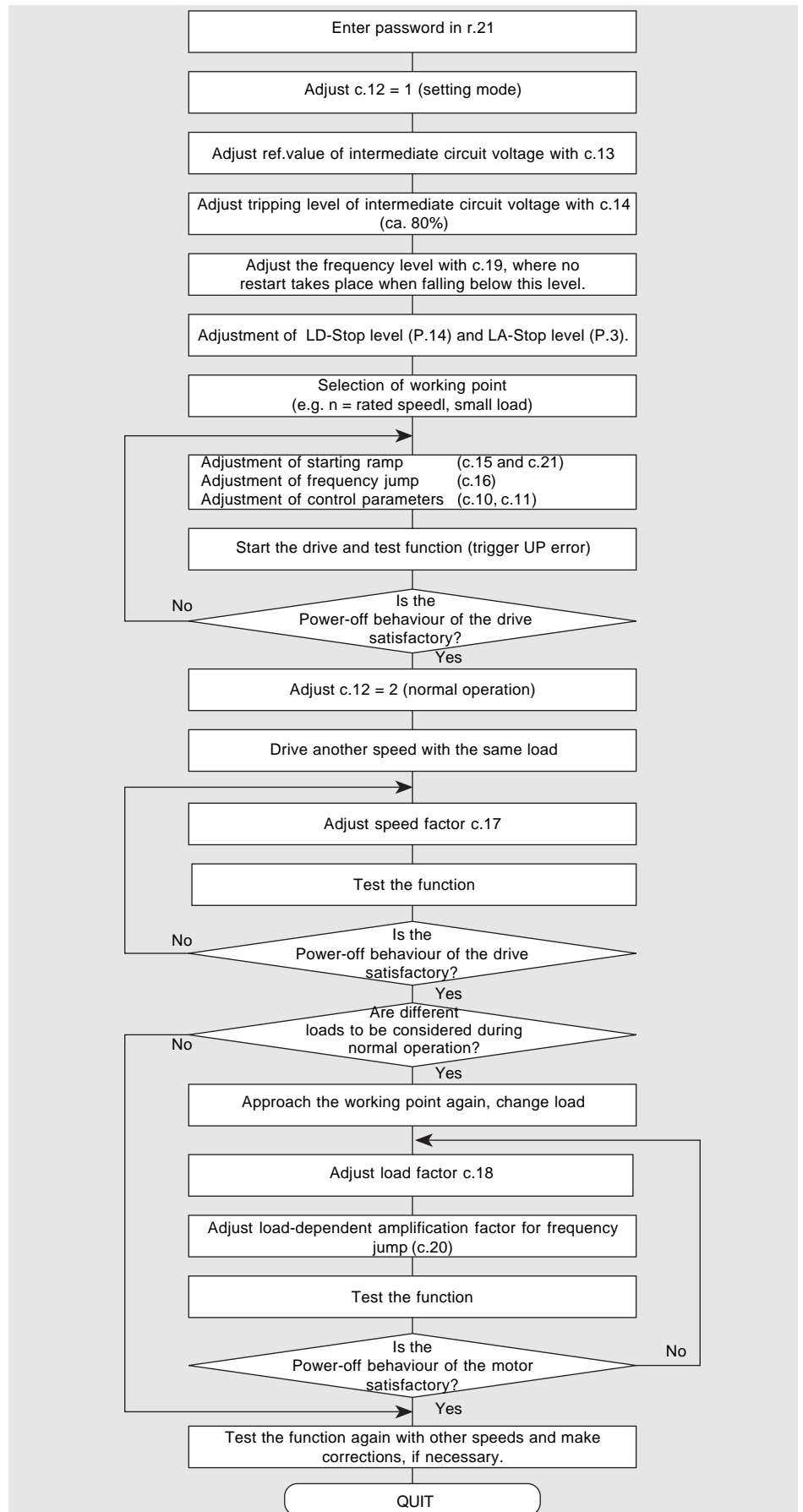

# Special Settings

## PROGRAMMING OF PARAMETER SETS

Following parameter sets are not programmable, i.e. their value is always the same in all parameter sets.

o.18	H.0	C.4	C.30	c.10	c.18
	H.7	C.5	C.31	c.11	c.19
P.18	H.12	C.9	C.32	c.12	c.20
	H.13	C.12	C.33	c.13	c.21
	H.14	C.13	C.34	c.14	c.22
	H.15	C.21		c.15	c.23
	H.16	C.25		c.16	
	H.17	C.29		c.17	

These parameters can be changed regardless in which set the programmer is at the time. The loading of the default set to the sets 1...7 has no effect on the above listed parameters. However, by loading the default set to set 0 the parameters can be reset.

All parameters of the D-control board are on-line changeable.

Exception: When the default set shall be copied to another set with F.3 (based on para set) the control release must be enabled!

Programming flow chart  
(values in brackets apply to bus operation)

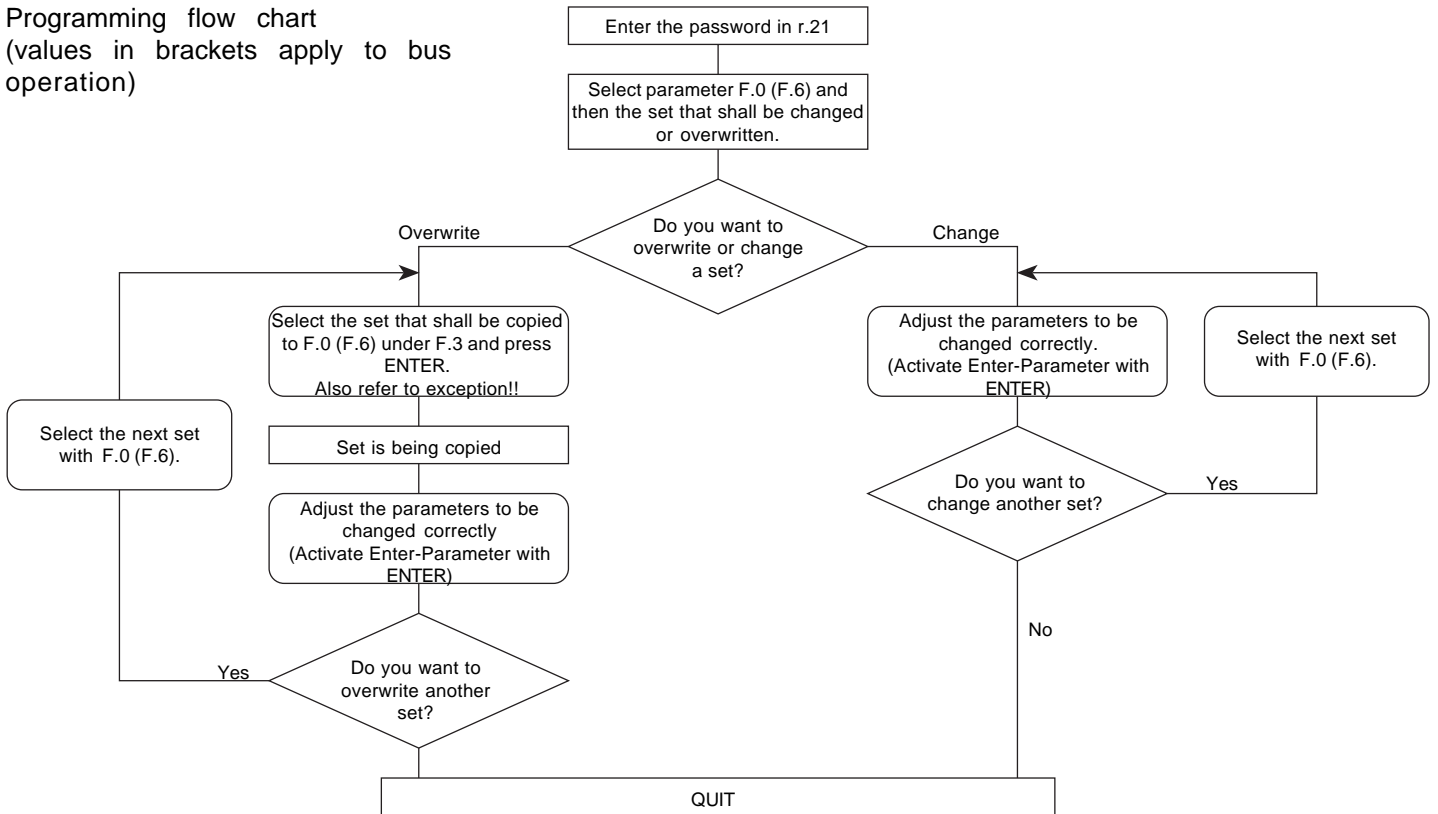

## Used Parameters

Parameter	Address	Value range	Correcting range	Resolution	Factory setting	Standard	Flags	Remarks
F.0	0600h	-1...7	A/0...7	1	0	0	L3	by bus only readable
F.3	0603h	-1...7	d/0...7	1	0	0	L3	—
F.6	0606h	-1...7	A/0...7	1	0	0	L3	only for bus operation

P = programmable Parameter L0 = no Password L3 = Customer Password R = Read-only-Parameter E = Enter Parameter

## BUS OPERATION

The KEB COMBIVERT 56D/F1 incorporates an integrated potential-separated RS232/RS485 interface. The communication with data communications equipment can take place independent of the wiring according to

- EIA-RS232 Standard (DIN 66020, 66022, CCITT V.24) or
- EIA-RS485 Standard (DIN 66259, Part 4).

The control procedure with the 7-bit code (ASCII) corresponds to the protocol KEB-DIN66019 (ANSI X3.28, ISO 1745).

Electrical characteristic EIA-RS232 Standard (DIN 66020, 66022, CCITT V.24)

Structure: Point-to-point connection  
 Medium: 3-wire cable, shielded, twisted  
 Cable length: maximal 15 m

Electrical characteristic EIA-RS485 Standard

Bus structure: Line closed at both ends with the terminating resistor, stub line - 1 m  
 Medium: 4/2-wire cables, shielded, twisted, wave impedance 80...120 Ω, min. 0,22 mm<sup>2</sup> and ca. 60 pF/m  
 Cable length: max. 1000 m  
 Connection: max. 32 units without line driver, with line driver limited only by the protocol (address range 0...239)  
 Level specification: RS485, full and half duplex  
 Line termination: 100...150 Ω switchable  
 Line rest potential: firmly wired internally

## Occupancy of serial interface

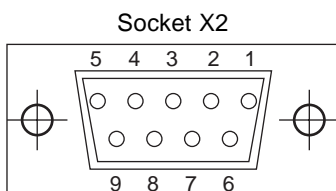

Occupancy of socket X2				
PIN No.	RS485	Ref./Norm	Signal	Meaning
1	—	—	—	—
2	—	—	TxD	Transmit signal/RS232
3	—	—	RxD	Receive signal/RS232
4	A'	—	RxD-A	Receive signal A/RS485
5	B'	—	RxD-B	Receive signal B/RS485
6	—	—	VP	Supply voltage-Plus, +5V referring to GND, I <sub>max</sub> = 50mA
7	C/C'	—	GND	Data reference potential
8	A	—	TxD-A	Transmit signal A/RS485
9	B	—	TxD-B	Transmit signal B/RS485

## Configuration of interface

C.12	Baud rate
0	1200 Baud
1	2400 Baud
2	4800 Baud
3	9600 Baud

C.13	Inverter address
	0...239

C.21	Watchdog time
0	= oFF
	0.05 s...9.95 s

r.18	Bus address display
	0...239

# Special Settings

## Connection RS232

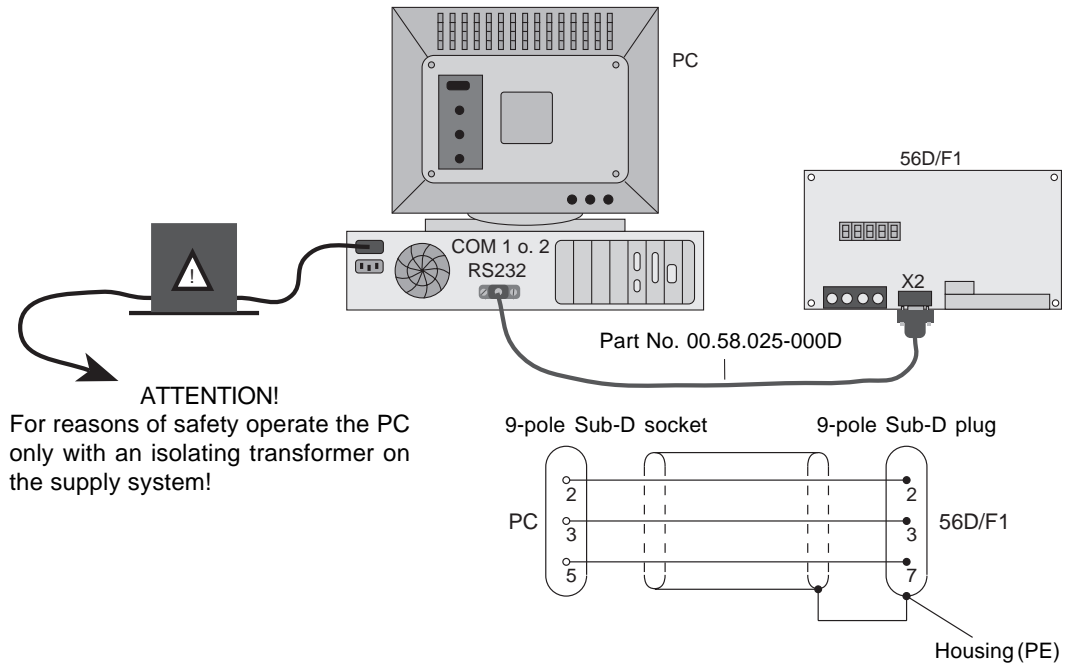

## Connection RS485 full duplex

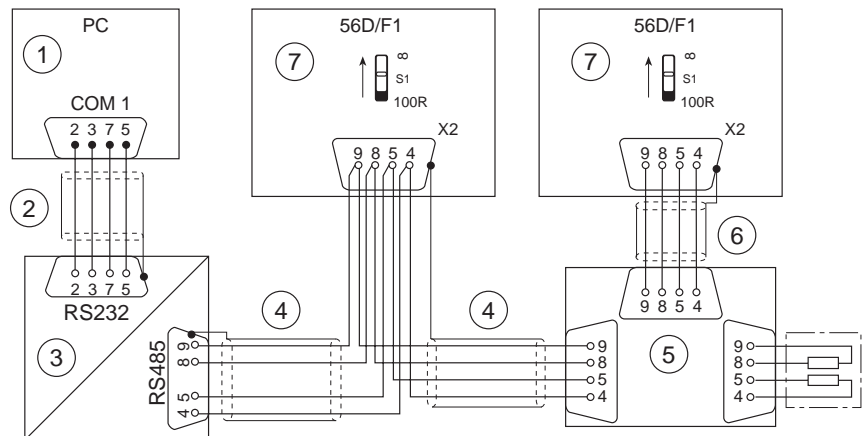

## Connection RS485 half duplex

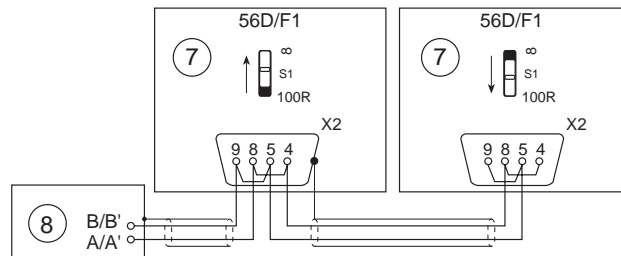

①	PC with 9-pole serial interface		⑤	Bus terminal for simple installation	00.58.025-0009
②	PC/Interface cable	00.58.025-000C	⑥	Stub line	00.58.025-0004
③	Interface RS232/RS485	00.58.025-0008	⑦	Control board	
④	Bus line consisting of:		⑧	Any chosen RS485-Master	
	• Cable 2x2x0,22 mm <sup>2</sup> shielded	00.90.829-0402			
	• Connector 9-pole Sub-D	00.90.501-7712			
	• Housing for Sub-D connector	00.90.501-7709			



## Adjustment of interface

**COMBIVERT**

Baud rate (C.12): 9600 Baud  
 Inverter address (C.13): 1  
 PC: Mode COM1, 96, E, 7, 1  
 (not required for COMBIVIS)

COMBIVIS :  
 (System configurator)

## Actual Configuration

Inverter type:	8, F0/F1/58D/56D V1.2 *
Operating mode:	DIN 66019
Interface:	COM1 (Port: 3F8h/IRQ4)
Baud rate:	9600
Data bits:	7
Stop bits:	1
Parity:	even
Timeout time:	100 ms
Status address:	513
Broadcast address:	255
First inverter:	1
Last inverter:	1
Screen lines:	25

\* Starting with COMBIVIS version 3.2 Ø 25: F1/56D/58D V1.2



Note!

Before starting interconnected inverters check, whether the inverter addresses are correctly adjusted (r.18) , if necessary, adjust with (C.13).

## Special Settings

### COMMUNICATION PARAMETERS

The following section gives a survey of all parameters of the frequency inverter. They serve to control the inverter by bus.

Flags: R = Read-only-Parameters  
 P = Programmable in sets  
 D = Deletable by writing of value 0  
 L0 = Password level 0 (no Password)  
 L3 = Password level 3 (Customer Password)

Parameter	Address	Value range	Correcting range	Resolution	Factory setting	Standard	Flags	Remarks
r.0	0200h	0...999	0...99,9	0,1	1.2	1.2	R, L0	—
r.1	0201h	0...78	0...78	1	—	—	R, L0	see table page E114
r.2	0202h	0...32767	0...409,58	0,0125 Hz	—	—	R, L0	depends on user-definit.
r.3	0203h	0...32767	0...409,58	0,0125 Hz	—	—	R, L0	depends on user-definit.
r.4	0204h	0...999	0...999	1 V	—	—	R, L0	—
r.5	0205h	200...999	200...999	1 V	—	—	R, L0	—
r.6	0206h	200...999	200...999	1 V	—	—	R/D, L0	—
r.7	0207h	0...200	0...200	1 %	—	—	R, L0	—
r.8	0208h	0...200	0...200	1 %	—	—	R/D, L0	—
r.9	0209h	0...200	0...200	1 %	—	—	R/D, L0	—
r.10	020Ah	0...200	0...200	1 %	—	—	R/D, L0	—
r.11	020Bh	0...200	0...200	1 %	—	—	R/D, L0	—
r.12	020Ch	0...9999	0...999,9	0,1 A	—	—	R, L0	—
r.13	020Dh	0...9999	0...999,9	0,1 A	—	—	R, L0	—
r.14	020Eh	0...255	0...255	1	—	—	R, L0	—
r.15	020Fh	0...7	0...7	1	—	—	R, L0	—
r.18	0212h	0...239	0...239	1	1	1	R, L0	—
r.19	0213h	0...32767	0...409,58	0,0125 Hz	0 Hz	0 Hz	P, L0	depends on user-definit.
r.20	0214h	0...2	LS, F, r	1	0	0	P, L0	—
r.21	0215h	0...±32767	—	1	—	—	L0	-11=nPA -12=PA.3
r.23	0217h	0...7	0...7	1	0	0	(R), L0	R= depends on o.18
r.27	021Bh	0...9999	0...999,9	0,1 h	—	—	R,L0	—
r.28	021Ch	0...9999	0...9999000	1000 h	—	—	R, L0	—
r.29	021Dh	04095	0...409,5	0,1 Hz	—	—	R, L0	—
r.30	021Eh	0...100	0...100	1 °C	—	—	R, L0	only for Type F1
r.35	0223h	-1000...1000	-100,0...100,0	0,1 %	0 %	0 %	P, L0	—

Parameter	Address	Value range	Correcting range	Resolution	Factory setting	Standard	Flags	Remarks
o.0	0300h	0...255	0...25,5	0,1 %	2 %	2 %	P, L3	—
o.1	0301h	0...32767	0...o.2...(max. 409,58)	0,0125 Hz	0 Hz	0 Hz	P, L3	depends on user-definit.
o.2	0302h	0...32767	(min. 0)...o.1...409,58	0,0125 Hz	70 Hz	70 Hz	P, L3	depends on user-definit.
o.3	0303h	0...32767	0...o.4...(max. 409,58)	0,0125 Hz	0 Hz	0 Hz	P, L3	depends on user-definit.
o.4	0304h	0...32767	(min. 0)...o.3...409,58	0,0125 Hz	70 Hz	70 Hz	P, L3	depends on user definit.
o.5	0305h	160...32767	2...409,58	0,0125 Hz	70 Hz	70 Hz	P, L3	depends on user-definit.
o.6	0306h	1...19990	0,05...999,5	0,05 s	10 s	10 s	P, L3	—
o.7	0307h	160...32767	2...409,58	0,0125 Hz	70 Hz	70 Hz	P, L3	depends on user-definit.
o.8	0308h	1...19990	0,05...999,5	0,05 s	10 s	10 s	P, L3	—
o.9	0309h	160...32767	2...409,58	0,0125 Hz	70 Hz	70 Hz	P, L3	depends on user-definit.
o.10	030Ah	1...19990	0,05...999,5	0,05 s	10 s	10 s	P, L3	—
o.11	030Bh	160...32767	2...409,58	0,0125 Hz	70 Hz	70 Hz	P, L3	depends on user-definit.
o.12	030Ch	1...19990	0,05...999,5	0,05 s	10 s	10 s	P, L3	—
o.13	030Dh	0...9	0...9	1	3	3	P, L3	—
o.14	030Eh	0...255	0...25,5	0,1 %	0 %	0 %	P, L3	—
o.15	030Fh	1...510	0,05...25,5	0,05 s	0,1 s	0,1 s	P, L3	—
o.16	0310h	0...60	oFF; 0,05...3,0	0,05	oFF	oFF	P, L3	—
o.17	0311h	0...60	oFF; 0,05...3,0	0,05	oFF	oFF	P, L3	—
o.18	0312h	0...6	0...6	1	3	0	L3	—
o.19	0313h	0...60	oFF; 0,05...3,0	0,05	oFF	oFF	P, L3	—
o.20	0314h	0...60	oFF; 0,05...3,0	0,05	oFF	oFF	P, L3	—
Parameter	Address	Value range	Correcting range	Resolution	Factory setting	Standard	Flags	Remarks
P.0	0400h	10...151	10...150, oFF	1 %	150 %	150 %	P, L3	—
P.1	0401h	1...19990	0,05...999.5 s	0,05 s	1 s	1 s	P, L3	—
P.2	0402h	0...3	0...3	1	0	0	P, L3	—
P.3	0403h	10...199	10...199	1 %	120 %	120 %	P, L3	—
P.4	0404h	0...1	oFF...on	1	oFF	oFF	P, L3	—
P.6	0406h	0...15	0...15	1	0	0	P, L3	—
P.7	0407h	0...11	0...11	1	0	0	P, L3	—
P.8	0408h	0...5	0...5	1	0	0	P, L3	—
P.9	0409h	0...10	0...10	1	0	0	P, L3	—
P.10	040Ah	0...4	0...4	1	0	0	P, L3	—
P.11	040Bh	0...5	oFF; 1...5	1	oFF	oFF	P, L3	—
P.12	040Ch	30...130	30...130	1 %	100 %	100 %	P, L3	—
P.13	040Dh	0...7	0...7	1	1	1	P, L3	—
P.14	040Eh	200...800	200...800	1 V	375(720) V	375 (720) V	P, L3	200(400) V-Class
P.16	0410h	0...100	0...100	1 °C	70 °C	70 °C	P, L3	only for Type F1
P.17	0411h	160...32767	2,0...409,58	0,0125 Hz	70 Hz	70 Hz	P, L3	depends on user-definit.
P.18	0412h	0...1	oFF...on	1	1	1	L3	—
P.20	0414h	0...5	0...5	1	0	0	P, L3	—

## Special Settings

Parameter	Address	Value range	Correcting range	Resolution	Factory setting	Standard	Flags	Remarks
H.0	0B00h	0...11	0...11	1	0	0	L3	—
H.1	0B01h	0...7	0...7	1	0	0	P, L3	—
H.2	0B02h	0...3	0...3	1	0	0	P, L3	—
H.3	0B03h	0...7	0...7	1	0	0	P, L3	—
H.4	0B04h	0...20	0...20	1	0	0	P, L3	—
H.5	0B05h	0...20	0...20	1	7	0	P, L3	—
H.6	0B06h	0...20	0...20	1	2	0	P, L3	—
H.7	0B07h	0...15	0...15	1	0	0	L3	—
H.9	0B09h	0...5	0...5	1	0	0	P, L3	—
H.10	0B0Ah	0...100	0...100	1 %	0 %	0 %	P, L3	—
H.11	0B0Bh	-2000...2000	-20,00...20,00	0,01	1,00	1,00	P, L3	—
H.12	0B0Ch	0...7	0...7	1	1	0	L3	—
H.13	0B0Dh	0...7	0...7	1	1	0	L3	—
H.14	0B0Eh	0...7	0...7	1	3	0	L3	—
H.15	0B0Fh	0...7	0...7	1	5	0	L3	—
H.16	0B10h	0...15	0...15	1	0	0	L3	—
H.17	0B11h	0...1	0...1	1	1	1	L3	—
H.18	0B12h	0...100	0...100	1 %	0 %	0 %	P, L3	—

Parameter	Address	Value range	Correcting range	Resolution	Factory setting	Standard	Flags	Remarks
L.0	0D00h	0...32767	0...409,58	0,0125 Hz	0 Hz	0 Hz	P, L3	depends on user-definit.
L.1	0D01h	0...32767	0...409,58	0,0125 Hz	4 Hz	4 Hz	P, L3	depends on user-definit.
L.2	0D02h	0...200	0...200	1 %	50 %	50 %	P, L3	—
L.3	0D03h	0...200	0...200	1 %	100 %	100 %	P, L3	—
L.4	0D04h	0...9999	0...999,9	0,1 A	0 A	0 A	P, L3	—
L.5	0D05h	0...9999	0...999,9	0,1 A	0 A	0 A	P, L3	—
L.6	0D06h	0...32767	0...409,58	0,0125 Hz	0 Hz	0 Hz	P, L3	depends on user-definit.
L.7	0D07h	0...255	0...25,5	0,1 %	10 %	10 %	P, L3	—
L.8	0D08h	0...2000	0...100	0,05 s	10 s	0,1 s	P, L3	—
L.9	0D09h	0...100	0...100	1 %	66 %	100 %	P, L3	—
L.10	0D0Ah	0...32767	0...L.11	0,0125 Hz	0 Hz	0 Hz	P, L3	depends on user-definit.
L.11	0D0Bh	0...32767	L.10...L.12	0,0125 Hz	0 Hz	0 Hz	P, L3	depends on user-definit.
L.12	0D0Ch	0...32767	L.11...L.13	0,0125 Hz	0 Hz	0 Hz	P, L3	depends on user-definit.
L.13	0D0Dh	0...32767	L.12...L.14	0,0125 Hz	0 Hz	0 Hz	P, L3	depends on user-definit.
L.14	0D0Eh	0...32767	L.13...L.15	0,0125 Hz	0 Hz	0 Hz	P, L3	depends on user-definit.
L.15	0D0Fh	0...32767	L.14...409,58	0,0125 Hz	0 Hz	0 Hz	P, L3	depends on user-definit.
L.16	0D10h	0...32766	0...327,66	0,01 s	0 s	0 s	P, L3	—

Parameter	Address	Value range	Correcting range	Resolution	Factory setting	Standard	Flags	Remarks
d.0	0500h	200...4000	20.0...400.0	0,1	50 Hz	50 Hz	P, L3	—
d.2	0502h	0...32767	0...409,58	0,0125 Hz	0 Hz	0 Hz	P, L3	depends on user-definit.
d.5	0505h	100...25000	100...25000	1 rpm	1470 rpm	1470 rpm	P, L3	—
d.6	0506h	1...2000	0,1...200,0	0,1 A	30,0 A	30,0 A	P, L3	—
d.7	0507h	200...30000	20,0...3000,0	0,1 Hz	50 Hz	50 Hz	P, L3	—
d.8	0508h	50...100	0,50...1,00	0,01	0,86	0,86	P, L3	—
d.10	050Ah	0...15000	0...150,00	0,01 ý	0,06 ý	0,06 ý	P, L3	—
d.18	0512h	0...255	0...2,55	0,01	1.00	1.00	P, L3	—
d.19	0513h	0...255	0...2,55	0,01	1.00	1.00	P, L3	—

Parameter	Address	Value range	Correcting range	Resolution	Factory setting	Standard	Flags	Remarks
C.0	0700h	0...32767	0...409,58	0,0125 Hz	409,58 Hz	409,58 Hz	P, L3	depends on user-definit.
C.1	0701h	0...32767	0...409,58	0,0125 Hz	409,58 Hz	409,58 Hz	P, L3	depends on user-definit.
C.2	0702h	0...3	F r, F -, - r, --	1	0	0	P, L3	—
C.3	0703h	0...1	0...1	1	1	1	L3	—
C.4	0704h	0...35	0...35	1	1	1	L3	—
C.5	0705h	0...15	0...15	1	0	0	L3	—
C.7	0707h	0...9	0...9	1	7	0	P, L3	—
C.9	0709h	0...31	0...31	1	0	0	L3	—
C.10	070Ah	150...650	150...649, oFF	1 V	oFF	oFF	P, L3	—
C.12	070Ch	0...3	0...3	1	3	3	L3	—
C.13	070Dh	0...239	0...239	1	1	1	L3	—
C.14	070Eh	0...31	0...31	1	0	0	L3	—
C.15	070Fh	0...3	0...3	1	3	3	P, L3	—
C.17	0711h	367...16000	367...C.18	1 Hz	0,367 kHz	0,367 kHz	P, L3	—
C.18	0712h	367...16000	C.17...2 kHz (16 kHz)	1 Hz	0,83/(4) kHz	0,83/(4) kHz	P, L3	Type 56 (Type F1)
C.19	0713h	0...32767	0...C.20	0,0125 Hz	0 Hz	0 Hz	P, L3	depends on user-definit.
C.20	0714h	0...32767	C.19...409,58	0,0125 Hz	0 Hz	0 Hz	P, L3	depends on user-definit.
C.21	0715h	0...199	oFF; 0,05...9,95	0,05 s	0 s	0 s	L3	—
C.22	0716h	-8000...8000	-100,0...100,0	0,0125 Hz	0 Hz	0 Hz	P, L3	depends on user-definit.
C.23	0717h	0...5	0...5	1	3	3	L3	—
C.25	0719h	0...1	oFF...on	1	oFF	oFF	L3	—
C.28	071Ch	0...8000	0...100,0	0,0125 Hz	0,5 Hz	0,5 Hz	P, L3	—
C.29	071Dh	0...1	oFF...on	1	oFF	oFF	L3	—
C.30	071Eh	-9999...9999	-9999...9999	1	1500	1500	L3	—
C.31	071Fh	1...9999	1...9999	1	4000	4000	L3	—
C.32	0720h	-9999...9999	-9999...9999	1	0	0	L3	—
C.33	0721h	0...4	0...4	1	1	1	L3	—
C.34	0722h	0...255	0...255	1	0	0	L3	—

## Special Settings

Parameter	Address	Value range	Correcting range	Resolution	Factory setting	Standard	Flags	Remarks																
F.0	0600h	-1,0...7	A, 0...7	1	0	—	R, L0	by bus only readable																
F.3	0603h	-1,0...7	d, 0...7	1	0	—	L0	"d" only for status nOP																
F.6	0606h	-1, 0...7	A, 0...7	1	—	—	L0	only for bus operation																
<table border="1"> <thead> <tr> <th>Message</th> <th>Bus value</th> <th>Display</th> <th>Meaning</th> </tr> </thead> <tbody> <tr> <td>no Password</td> <td>-16</td> <td>nPA</td> <td>Before copying sets a password must be entered</td> </tr> <tr> <td>not copied</td> <td>-17</td> <td>nco</td> <td>Attempted copying of a set to itself or of the default set while control release is closed.</td> </tr> <tr> <td>copied</td> <td>-18</td> <td>PASS</td> <td>Set has been successfully overwritten</td> </tr> </tbody> </table>									Message	Bus value	Display	Meaning	no Password	-16	nPA	Before copying sets a password must be entered	not copied	-17	nco	Attempted copying of a set to itself or of the default set while control release is closed.	copied	-18	PASS	Set has been successfully overwritten
Message	Bus value	Display	Meaning																					
no Password	-16	nPA	Before copying sets a password must be entered																					
not copied	-17	nco	Attempted copying of a set to itself or of the default set while control release is closed.																					
copied	-18	PASS	Set has been successfully overwritten																					

Parameter	Address	Value range	Correcting range	Resolution	Factory setting	Standard	Flags	Remarks
c.8	0908h	0...3	0...3	1	0	0	P, L3	—
c.10	090Ah	0...255	0...255	1	0	0	L3	0 = off
c.11	090Bh	0...255	0...255	1	0	0	L3	0 = off
c.12	090Ch	0...2	0...2	1	0	0	L3	1=setting, 2=normal operation
c.13	090Dh	100...150	100...150	1 %	100 %	100 %	L3	--
c.14	090Eh	50...100	50...100	1 %	80 %	80 %	L3	--
c.15	090Fh	1...19990	0.05...999.5	0.05 s	41 s	41 s	L3	--
c.16	0910h	0...2000	0...25	0.0125 Hz	2 Hz	2 Hz	L3	depends on user-definit.
c.17	0911h	0...4095	0...4095	1	0	0	L3	--
c.18	0912h	0...4095	0...4095	1	0	0	L3	--
c.19	0913h	0...32767	0...409.58	0.0125 Hz	0 Hz	0 Hz	L3	depends on user-definit.
c.20	0914h	0...4095	0...4095	1	0	0	L3	--
c.21	0915h	100...32767	1.25...409.48	0.0125 Hz	70 Hz	70 Hz	L3	depends on user definit..25
c.22	0916h	0...255	0...255	1	12	12	L3	—
c.23	0917h	0...255	0...255	1	6	6	L3	—

Parameter	Address	Value range	Correcting range	Resolution	Factory setting	Standard	Flags	Remarks
I.0	1600h	0...11	*)	1	—	—	R, L0	—
I.1	1601h	1...2000	0,1...200,0	0,1 A	—	rated current	R, L0	—
I.2	1602h	20...30000	20.0...3000,0	0,1 Hz	—	409,5 Hz	R, L0	—
I.3	1603h	0...32767	0...32767	1	—	—	R, L0	—
I.4	1604h	0...32767	0...32767	1	—	—	R, L0	—
I.5	1605h	0...32767	0...32767	1	—	—	R, L0	—
I.6	1606h	0...32767	0...32767	1	—	—	R, L0	—
I.7	1607h	0...32767	0...32767	1	—	—	R, L0	—
I.8	1608h	0...32767	0...32767	1	—	—	R, L0	—
I.9	1609h	0...32767	0...32767	1	—	—	R, L0	—
I.10	160Ah	0...32767	0...32767	1	—	—	R, L0	—
I.11	160Bh	0...32767	0...32767	1	—	—	R, L0	—
I.12	160Ch	0...32767	0...32767	1	—	—	R, L0	—
I.13	160Dh	0...32767	0...32767	1	—	—	R, L0	—
I.14	160Eh	0...32767	0...32767	1	—	—	R, L0	—
I.15	160Fh	1...999	1...999	1	at the time "8" with COMBIVIS 3.2 "25"		(R), L0	by bus only standard values writable
I.16	1610h	01010...31129	0101,0...3112,9	0,1	—	—	R, L0	—

*) Value	Display	Inverter type	Value	Display	Inverter type
0	F0.2	F0 / 200V-Class	6	56c.2	56C / 200V-Class
1	F0.4	F0 / 400V-Class	7	56c.4	56C / 400V-Class
2	F1.2	F1 / 200V-Class	8	56d.2	56D / 200V-Class
3	F1.4	F1 / 400V-Class	9	56d.4	56D / 400V-Class
4	F2.2	F2 / 200V-Class	10	SPECL	Special version
5	F2.4	F2 / 400V-Class	11	no Id	no identification

Parameter	Address	Value range	Correcting range	Resolution	Factory setting	Standard	Flags	Remarks
Pr.4	0104h	2...12	2...12	2	4	4	R, L0	d.7 - 120 d.5
Pr.5	0105h	0...65535	0...65535	1	—	—	R, L0	see table page E114
Pr.6	0106h	0...65535	0...65535	1	—	—	L0	only active if C.25 = "on" also refer to page E25
Pr.7	0107h	0...65535	0...65535	1	—	—	R, L0	—
Pr.8	0108h	-32768...32767	-32768...32767	1 rpm	0 rpm	0 rpm	L0	only effective at o.13 = "5"
Pr.9	0109h	-32768...32767	-32768...32767	1 rpm	—	—	R, L0	—
Pr.10	010Ah	0...32767	0...Pr.11	1 rpm	0 rpm	0 rpm	P, L0	—
Pr.11	010Bh	0...32767	Pr.10...32767	1 rpm	2100 rpm	2100 rpm	P, L0	—
Pr.16	0110h	100...32767	100...32767	1 rpm	2100 rpm	2100 rpm	P, L0	—
Pr.18	0112h	1...999	1...999	1 s	10 s	10 s	P, L0	—
Pr.25	0119h	100...32767	100...32767	1 rpm	2100 rpm	2100 rpm	P, L0	—
Pr.27	011Bh	1...999	1...999	1 s	10 s	10 s	P, L0	—
Pr.37	0125h	-32768...32767	-32768...32767	1 rpm	—	—	R, L0	—
Pr.38	0126h	-32768...32767	-32768...32767	1	0	0	L0	only effective at o.13 = "9" ; corresponds -200 % to 200 %
Pr.39	0127h	0...32767	0...32767	1 rpm	0 rpm	0 rpm	L0	—
Pr.40	0128h	-32768...32767	-32768...32767	1	—	—	R, L0	corresponds -200 % to 200 %
Pr.41	0129h	-32768...32767	-32768...32767	1	—	—	R, L0	—

## CONTROL WORD AND STATUS WORD

With parameter C.25 (= on) the KEB COMBIVERT can be put into the DRIVECOM- mode where it reacts to a control word (Pr.6). With the control word the inverter is put into firmly defined conditions (grey fields in the flow chart), which can be read by way of the status word (Pr.7). The parameters Pr.6 and Pr.7 can be read or changed only by bus.

In the flow chart the minimal control words are listed for the respective function. Please refer to the Instruction Manual InterBus-S to learn about the structure of the control word.

State diagram for control word Pr.6 and status word Pr.7

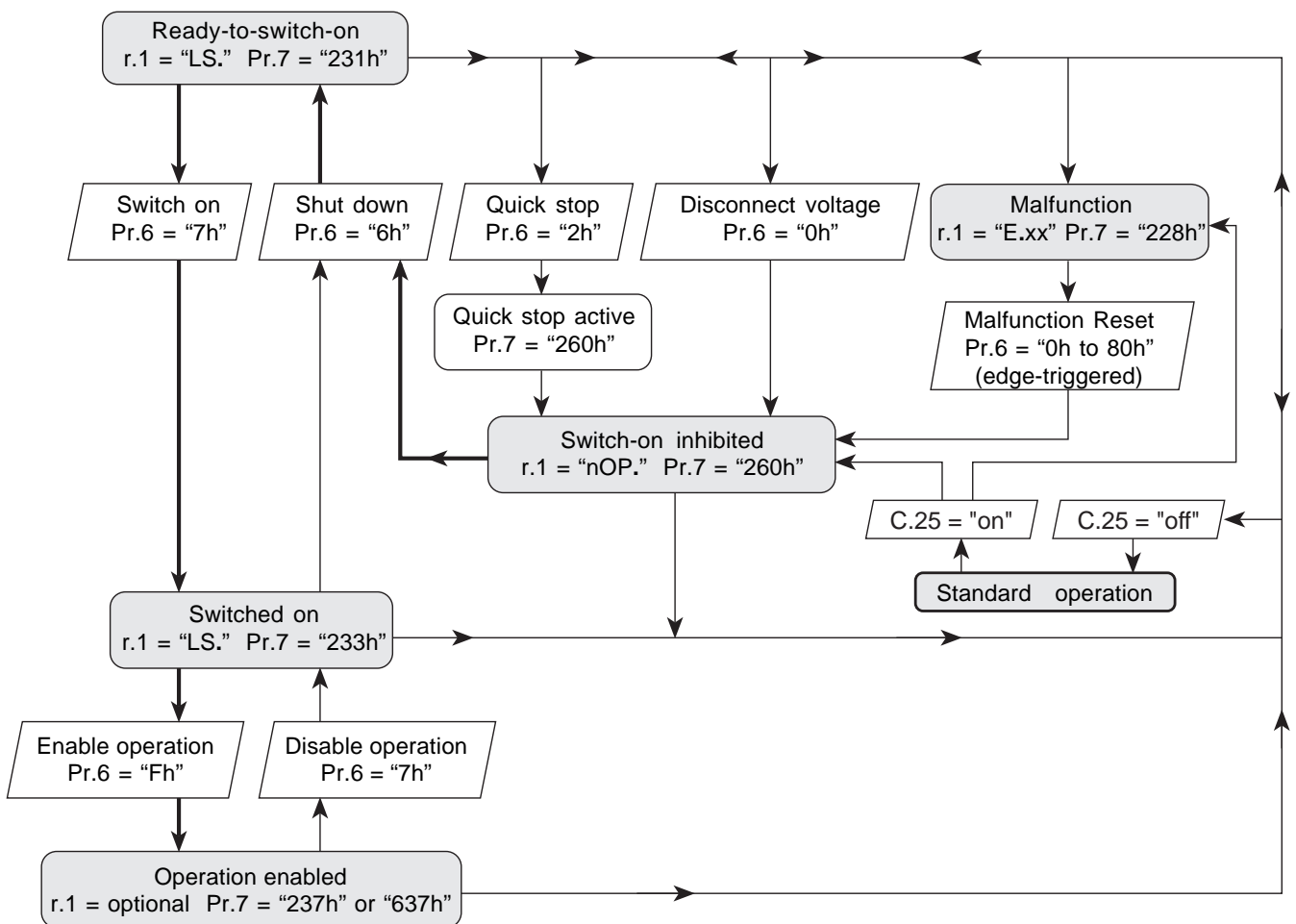

### Example

Use of the control word: Reset by bus

Error	r.1	e.g.	
	r.21	= XXX	Password input
	C.25	= on	Activate control word Pr.6
	Pr.6	= 0h	
	Pr.6	= 80h	Carry out reset (edge-triggered)
	C.25	= oFF	Deactivate control word



Connection of Control Board  
Page E4 - E14

Operation of the Unit  
Page E15 - E22

Starting  
Page E23 - E30

Parameters  
Page E31 - E68

Special Settings  
Page E69 - E112

✓ Annex  
Page E113 - E122

Index  
Page E123 - E124



- 1 Error messages  
Status messages
- 2 Basic settings/Presettings
- 3 Password
- 4 Abridged instructions

# Annex 1 Error/Status messages

## Error messages

Display	Bus value r.1 Error code Pr.5	Meaning			
				17 0000h	Cooling time after overload (OL) has elapsed .
	1 3210h	Overvoltage, intermediate circuit voltage too high		18 8100h	Watchdog error, transmission error
	2 3220h	Undervoltage, intermediate circuit voltage too low or phase failure		39 6300h	Error in set selection Set 0
	3 3220h	Undervoltage in the driver circuit		20 6301h	Error in set selection Set 1
	4 2200h	Overcurrent (dependent on power circuit)		29 630Ah	Error in set selection Set 10
	5 2200h	Overcurrent (dependent on power circuit)		40 630Bh	Error in set selection Set 11
	6 2330h	Ground fault		44 630Fh	Error in set selection Set 15
	7 5400h	Intermediate circuit fuse defective		30 4310h	Response of motor protective relay
	8 4200h	Overtemperature, external triggering by OH terminals		31 9000h	External error see H.12...H.15
	9 4210h	Overheating of inverter		33 1000h	Short-circuit at digital outputs or supply voltage of outputs is missing
	15 3230h	Charge resistor error		36 0000h	Below temperature level after E.OH1
	16 2300h	Overload		37 1000h	LS after power-off

## Status messages

	0 0000h	Power module released, control release not jumpered		70 -	Low Speed at activated control word C.25
	0 0000h	like above, but with activated control word C.25		71 -	Current limit active
	64 -	Accelerating, forward direction of rotation		72 -	Acceleration stop active
	65 -	Decelerating, forward direction of rotation		73 -	Deceleration stop active
	66 -	Constant operation, forward direction of rotation		74 -	Speed Search active
	67 -	Accelerating, reverse direction of rotation		75 -	DC-Braking active
	68 -	Decelerating, reverse direction of rotation		76 -	Base-Block-time (blocking of power modules for motor de-excitation)
	69 -	Constant operation, reverse direction of rotation		77 -	LS after DC-Braking
	70 -	Low Speed, no direction of rotation		78 -	Power-off function active
	-11 -	no password level enabled		- -	Enter-Parameter; value is activated and stored only by pressing ENTER

No.	Parameter name	Basic Setting (default values) Unit	Presetting Set							
			0	1	2	3	4	5	6	7
r.19	Reference setting	0 Hz		5	50	70				
r.20	Rotation setting <sup>1)</sup>	LS								
r.35	Reference setting in percent	0 %								
o.0	Boost	2 %								
o.1	Minimum reference A	0 Hz								
o.2	Maximum reference A	70 Hz								
o.3	Minimum reference B	0 Hz								
o.4	Maximum reference B	70 Hz								
o.5	Acceleration speed A	70 Hz								
o.6	Acceleration time A	10 s								
o.7	Deceleration speed A	70 Hz								
o.8	Deceleration time A	10 s								
o.9	Acceleration speed B	70 Hz								
o.10	Acceleration time B	10 s								
o.11	Deceleration speed B	70 Hz								
o.12	Deceleration time B	10 s								
o.13	Input source <sup>1)</sup>	3		1	1	1				
o.14	Delta-Boost	0 %								
o.15	Delta-Boost time	0,1 s								
o.16	S-curve acceleration time A	oFF								
o.17	S-curve deceleration time A	oFF								
o.18	Select parameter set source <sup>1)</sup>	0	3	-	-	-	-	-	-	-
o.19	S-curve acceleration time B	oFF								
o.20	S-curve deceleration time B	oFF								
P.0	Stall prevention level	150 %								
P.1	ACC/DEC time during stall prevention	1 s								
P.2	Stall torque characteristic <sup>1)</sup>	0								
P.3	LAD stop load level	120 %								
P.4	U/f function	oFF								
P.6	Speed search condition	0								
P.7	Automatic retry UP	0								
P.8	Automatic retry OC	0								
P.9	Automatic retry OP	0								
P.10	Motor protection	0								

## Annex 2 Basic setting/Presetting

No.	Parameter name	Basic Setting (default values) Unit	Presetting Set							
			0	1	2	3	4	5	6	7
P.11	Energy-saving mode <sup>1)</sup>	oFF								
P.12	Energy-saving level	100								
P.13	LAD stop condition	1								
P.14	LD stop DC voltage level	375 (720) V <sup>2)</sup>								
P.16	Heat sink temperature warning level	70 °C								
P.17	ACC/DEC speed during stall prevention	70 Hz								
P.18	Hardware current limitation	on								
P.20	Speed search mode	0								
H.0	Presetting mode reference value <sup>1)</sup>	0		-	-	-	-	-	-	-
H.1	Logic of analog inputs <sup>1)</sup>	0								
H.2	AUX input function <sup>1)</sup>	0								
H.3	Output logic <sup>1)</sup>	0								
H.4	Out1 - function <sup>1)</sup>	0								
H.5	Out2 - function <sup>1)</sup>	0	7	7	7	7				
H.6	Out3 - function <sup>1)</sup>	0	2	2	2	2				
H.7	Input logic <sup>1)</sup>	0		-	-	-	-	-	-	-
H.9	Analog output function <sup>1)</sup>	0								
H.10	Analog output offset y	0								
H.11	Analog output gain	1,00								
H.12	I1 - function <sup>1)</sup>	0	1	-	-	-	-	-	-	-
H.13	I2 - function <sup>1)</sup>	0	1	-	-	-	-	-	-	-
H.14	I3 - function <sup>1)</sup>	0	3	-	-	-	-	-	-	-
H.15	I4 - function <sup>1)</sup>	0	5	-	-	-	-	-	-	-
H.16	Input triggering function <sup>1)</sup>	0		-	-	-	-	-	-	-
H.17	Shift mode parameter set	1	1	-	-	-	-	-	-	-
H.18	Analog output offset x	0								
L.0	Actual value level 1	0 Hz								
L.1	Actual value level 2	4 Hz								
L.2	Load level 1	50 %								
L.3	Load level 2	100 %								
L.4	Active current level 1	0,0 A								
L.5	Active current level 2	0,0 A								
L.6	DC dynamic braking level	0,0 Hz								
L.7	DC dynamic voltage level	10,0 %								

No.	Parameter name	Basic Setting (default values) Unit	Presetting Set							
			0	1	2	3	4	5	6	7
L.8	DC dynamic braking time	0,1 s								
L.9	OL warning signal	100 %	66	66	66	66				
L.10	Setting prohibition 1 / value low	0,0 Hz								
L.11	Setting prohibition 1 / value high	0,0 Hz								
L.12	Setting prohibition 2 / value low	0,0 Hz								
L.13	Setting prohibition 2 / value high	0,0 Hz								
L.14	Setting prohibition 3 / value low	0,0 Hz								
L.15	Setting prohibition 3 / value high	0,0 Hz								
L.16	Timer value	0,0 s								
d.0	Rated frequency	50 Hz								
d.2	Lower modulation limit	0,0 Hz								
d.5	Rated motor speed	1470 rpm								
d.6	Rated motor current	30,0 A								
d.7	Rated motor frequency	50 Hz								
d.8	Rated motor cos $\varphi$	0,86								
d.10	Motor terminal resistance	0,60 $\Omega$								
d.18	Slip compensation / frequency gain	1,0								
d.19	Slip compensation / auto torque gain	1,0								
C.0	Limit of maximum reference A	409,5 Hz								
C.1	Limit of maximum reference B	409,5 Hz								
C.2	Rotation lock <sup>1)</sup>	F r								
C.3	Rotation input	1								
C.4	Condition display	1		-	-	-	-	-	-	-
C.5	Noise filter / digital inputs	0		-	-	-	-	-	-	-
C.7	DC-braking mode <sup>1)</sup>	0								
C.9	Parameter group lock	0		-	-	-	-	-	-	-
C.10	Output voltage stabilisation <sup>1)</sup>	oFF								
C.12	Baud rate	3		-	-	-	-	-	-	-
C.13	Inverter address	1		-	-	-	-	-	-	-
C.14	Zero clamp speed	0								
C.15	Select mode of modulation <sup>1)</sup>	3								
C.17	Min. carrier frequency	0,367 kHz								
C.18	Max. carrier frequency	0,83 kHz (Type 56) 4,0 kHz (Type F1)								
C.19	Vertex of min. carrier frequency	0								

## Annex 2 Basic setting/Presetting

No.	Parameter name	Basic Setting (default values) Unit	Presetting Set							
			0	1	2	3	4	5	6	7
C.20	Vertex of max. carrier frequency	0								
C.21	Watchdog time	oFF		-	-	-	-	-	-	-
C.22	Set value offset	0,0 Hz								
C.23	Noise filter / analog inputs	3		-	-	-	-	-	-	-
C.25	Control word activation	oFF		-	-	-	-	-	-	-
C.28	Switching hysteresis	0,5 Hz								
C.29	Display scaling / activation	oFF		-	-	-	-	-	-	-
C.30	Display scaling / multiplier	1500		-	-	-	-	-	-	-
C.31	Display scaling / divisor	4000		-	-	-	-	-	-	-
C.32	Display scaling / offset	0		-	-	-	-	-	-	-
C.33	Display scaling / post decimal position	1		-	-	-	-	-	-	-
C.34	Parameter set lock	0		-	-	-	-	-	-	-
c.8	Regulator selection	0								
c.10	P (Power off)	0		-	-	-	-	-	-	-
c.11	I (Power off)	0		-	-	-	-	-	-	-
c.12	Power off / mode	0		-	-	-	-	-	-	-
c.13	Power off / set DC voltage	100 %		-	-	-	-	-	-	-
c.14	Power off / DC tripping voltage	80 %		-	-	-	-	-	-	-
c.15	Power off / initial ramp time	41,0 s		-	-	-	-	-	-	-
c.16	Power off / frequency jump	2,0 Hz		-	-	-	-	-	-	-
c.17	Power off / freq.-depend.ramp correction	0		-	-	-	-	-	-	-
c.18	Power off / load-depend.ramp correction	0		-	-	-	-	-	-	-
c.19	Power off / min. restart limit	0,0		-	-	-	-	-	-	-
c.20	Power off / load-depend.freq.jump factor	0		-	-	-	-	-	-	-
c.21	Power off / initial ramp speed	70 Hz		-	-	-	-	-	-	-
c.22	P (DC-braking)	12		-	-	-	-	-	-	-
c.23	I (DC-braking)	6		-	-	-	-	-	-	-

Only in case of deviations from the basic setting values have been entered in the sets.

- not programmable

<sup>1)</sup> ENTER-Parameter, i.e. for non-volatile storing the ENTER key must be pressed twice.

<sup>2)</sup> 200 V Class (400 V Class)

## PASSWORD

In order to exclude any changing of the parameters by unauthorized personnel the passwords listed below should be removed from this Instruction Manual!

All parameters can be read even without entering a password. To enter the correct password you have 3 attempts. After 3 wrong inputs the password input is blocked until a restart of KEB COMBIVERT.



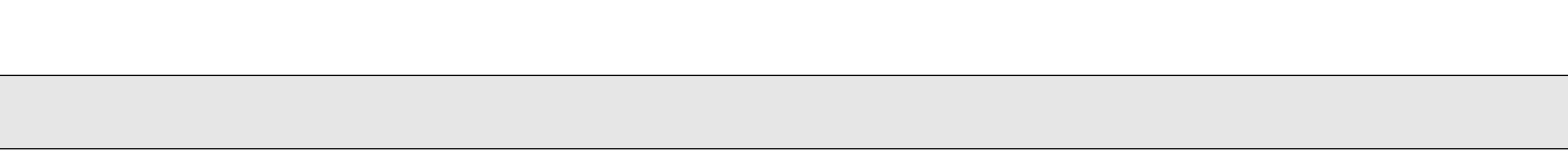

30 minutes after the last key actuation the password disappears and must be re-entered.

By entering 999 the password protection is reactivated!

Password level Password name	Keyboard		Bus		
	Input in r.21	Display	Input in r.21	Indication	Display COMBIVIS
0 Disable Password	999	nPa	999	-11	no Password
1 Set-up Password	255	PA.1			
2 User Password	465	PA.2			
3 Customer Password	261	PA.3	16300	-12	Customer Password

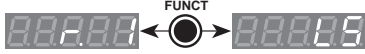

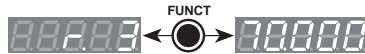
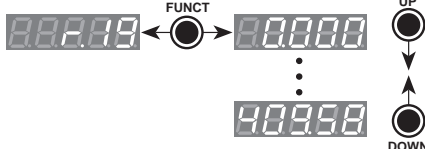
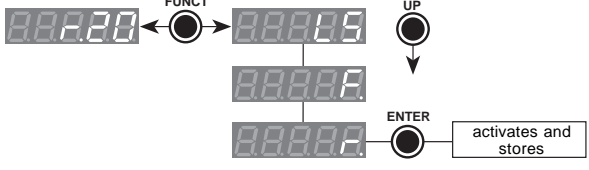
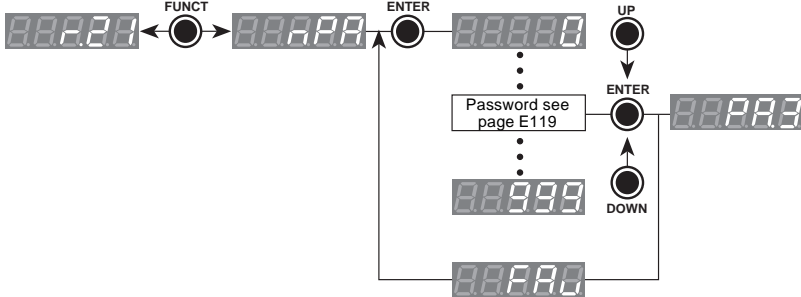
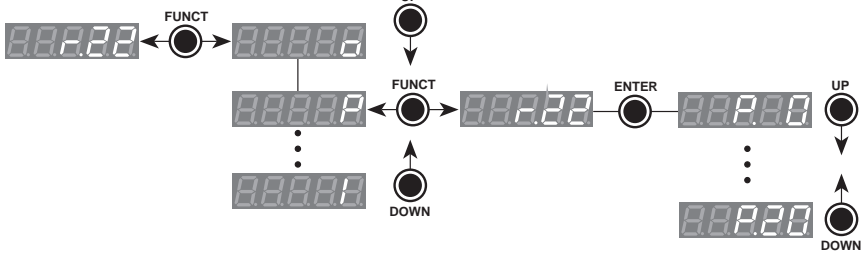

<p>Inverter status</p> <p>Indicates the operating condition of the inverter.</p>	
<p>Actual value display</p> <p>The standard indication is the actual output frequency. (Possible change of definition with C.29...C.33).</p>	
<p>Set value display</p> <p>Indicates the setpoint value preset by terminal strip, keyboard or bus. (Possible change of definition with C.29...C.33).</p>	
<p>Reference setting by keyboard</p> <p>Condition: o.13 = 0 or 1 Basic setting: r.19 = 0 Hz Customer setting: r.19 = _____ Hz</p>	
<p>Rotation setting by keyboard</p> <p>LS = standstill; F = forward; R = reverse Input becomes effective and is stored with ENTER. Condition: o.13 = 0, 2 or 6 Basic setting: r.20 = LS Customer setting: r.20 = _____</p>	
<p>Password input is necessary for parameterizing.</p> <p>In case of wrong input the display indicates FAu. After 3 wrong inputs the function is aborted with the indication noF and is only available again after a restart.</p>	
<p>Select parameter group</p> <p>With r.22 the parameter group is selected and jumped to by pressing ENTER.</p>	
<p>Current frequency</p> <p>Always indicates the current output frequency in Hz.</p>	

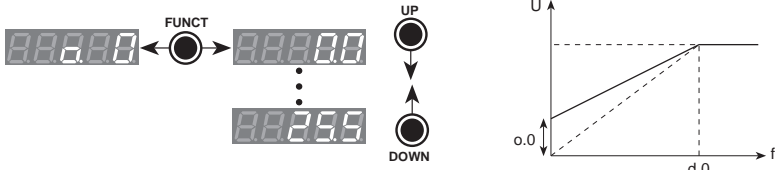
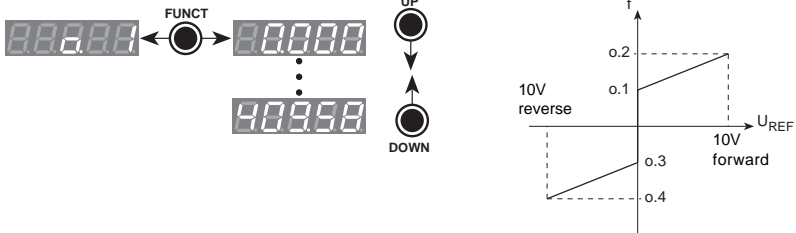
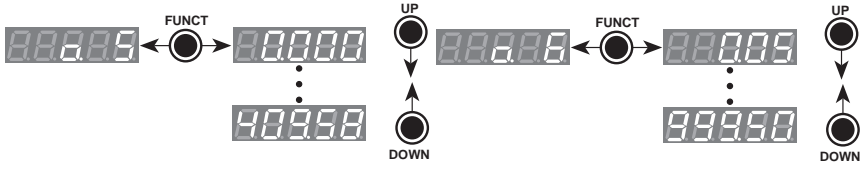
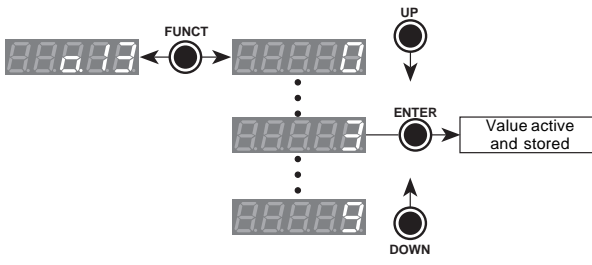
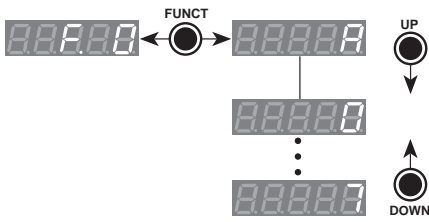
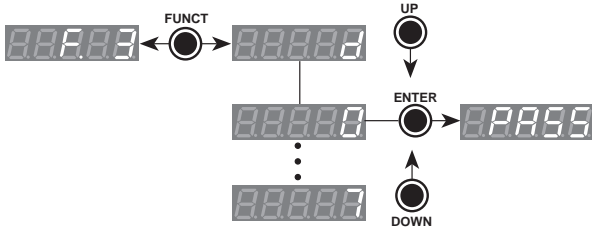
<p><b>Boost</b></p> <p>Basic setting: o.0 = 2 %          Customer setting: o.0 = _____</p>																																		
<p><b>Minimum frequency (o.1, o.3)          Maximum frequency(o.2, o.4)</b></p> <p>Basic setting: o.1, o.3 = 0 Hz          o.2, o.4 = 70 Hz          Customer setting: o.1 = _____ Hz          o.2 = _____ Hz          o.3 = _____ Hz          o.4 = _____ Hz</p>																																		
<p><b>Forward accelerat. o.5 Accelerat. speed A70 Hz          Forward decelerat. o.6 Accelerat. time A 10 s          o.7 Decelerat. speed A70 Hz          o.8 Decelerat. time A 10 s          Reverse accelerat. o.9 Accelerat. speed B70 Hz          o.10 Accelerat. time B 10 s          Reverse decelerat. o.11 Decelerat. speed B70 Hz          o.12 Decelerat. time B 10 s</b></p> <p>Customer setting: o.5 = ____ Hz o.6 = ____ s          o.7 = ____ Hz o.8 = ____ s          o.9 = ____ Hz o.10 = ____ s          o.11 = ____ Hz o.12 = ____ s</p>																																		
<p><b>Input source</b></p> <table border="1" data-bbox="110 1073 597 1335"> <thead> <tr> <th>Value</th> <th>Reference value</th> <th>Direction of roation</th> </tr> </thead> <tbody> <tr><td>0</td><td>Digital (r.19)</td><td>Digital (r.20)</td></tr> <tr><td>1</td><td>Digital (r.19)</td><td>Terminal</td></tr> <tr><td>2</td><td>Analog</td><td>Digital (r.20)</td></tr> <tr><td>3</td><td>Analog</td><td>Terminal</td></tr> <tr><td>4</td><td>Analog</td><td>Sign analog signal</td></tr> <tr><td>5</td><td>Bus profile (Abs) (Pr.8)</td><td>Sign bus profile</td></tr> <tr><td>6</td><td>Digital (%) (r.35)</td><td>Digital (r.20)</td></tr> <tr><td>7</td><td>Digital (%) (r.35)</td><td>Terminal</td></tr> <tr><td>8</td><td>Digital (%) (r.35)</td><td>Sign digital (%)</td></tr> <tr><td>9</td><td>Bus profile (%) (Pr.38)</td><td>Sign bus profile (%)</td></tr> </tbody> </table> <p>Basic setting: o.13 = 3          Customer setting: o.13 = _____</p>	Value	Reference value	Direction of roation	0	Digital (r.19)	Digital (r.20)	1	Digital (r.19)	Terminal	2	Analog	Digital (r.20)	3	Analog	Terminal	4	Analog	Sign analog signal	5	Bus profile (Abs) (Pr.8)	Sign bus profile	6	Digital (%) (r.35)	Digital (r.20)	7	Digital (%) (r.35)	Terminal	8	Digital (%) (r.35)	Sign digital (%)	9	Bus profile (%) (Pr.38)	Sign bus profile (%)	
Value	Reference value	Direction of roation																																
0	Digital (r.19)	Digital (r.20)																																
1	Digital (r.19)	Terminal																																
2	Analog	Digital (r.20)																																
3	Analog	Terminal																																
4	Analog	Sign analog signal																																
5	Bus profile (Abs) (Pr.8)	Sign bus profile																																
6	Digital (%) (r.35)	Digital (r.20)																																
7	Digital (%) (r.35)	Terminal																																
8	Digital (%) (r.35)	Sign digital (%)																																
9	Bus profile (%) (Pr.38)	Sign bus profile (%)																																
<p><b>Key parameter set no.</b></p> <p>Selection of a parameter set that shall be programmed by way of keyboard.          A: Indication of parameter values of the parameter set active at the time. The values cannot be altered.          0...7: All adjustment parameters show the values of the parameter set selected here even if another parameter set is active at the same time.</p>																																		
<p><b>Based on para-set</b></p> <p>The parameter set inidated here is copied to the set adjusted in F.0 with ENTER (requires Customer Password).          d: Default set          0...7: Parameter sets          When copying the default set the control release must be open!</p>																																		

- A
  - Abridged Instructions 121
  - Accelerating 28
  - Acceleration 36, 37
    - Delta-speed 67
    - Delta-time 67
  - Active current
    - Level 47, 48
  - Actual value
    - Actual speed value 66
    - Display 33
    - Level 47
    - Percentage 68
  - Address
    - Inverter address 54
  - Analog output 44, 46, 4b
  - Auto-Boost 51, 94
    - Activation 59
  - Automatic retry 40, 90
  - AUX 73
  - AUX-Input
    - Function 42
- B
  - Based on para-set 63
  - Basic Setting 115
  - Baud rate 54
  - Boost 30, 36
    - Delta Boost 38
    - Delta-Boost / time 38
  - Bus address 54
    - Display 34
  - Bus operation 103
  - Bus surveillance 56
- C
  - c(ontrol) Parameters 59-61
  - C(ustomer) Parameters 52-58
  - Carrier frequency min/max 55
  - COMBIVIS
    - Configuration 105
  - Communication Parameters 106
  - Condition display 24, 53
  - Connection
    - Bus operation 104
  - Control circuit
    - Survey 4a
    - Voltage supply 5
  - Control release 7
  - Control terminals 4b
  - Control word 66, 112
    - Activation 57
  - cos (phi)
    - Motor 51
- Current
  - Active current 34
  - Apparent current 34
- Current limitation
  - ACC/DEC speed during stall prevention 41
  - ACC/DEC time during stall prevention 39
- Current limitation
  - Hardware 41
  - Level 39
  - M-n-Characteristic 39
- D
  - d(rive) Parameters 50-51
  - DC-Braking 85
    - Activation 53
    - Adjustment 86
    - I-Factor 61
    - Level 48
    - Optimization 86
    - P-Factor 61
    - Terminal strip 8
    - Time 48
    - Voltage 48
  - Deceleration 28, 37
    - Speed 67
    - Time 67
  - Default values 115
  - Delta-Boost 30
  - Direction of rotation 70
    - Locking 52
  - Display 4a
    - Error messages 114
    - Status messages 114
  - Display scaling 57, 58, 97
  - DOWN-Key 16
- E
  - Energy saving function 93
    - Activation 40
    - Level 41
  - ENTER-Key 17, 18
  - ENTER-Parameter 18
  - Error counter 64, 65
  - Error messages 114
    - Resetting 19
- F
  - F(ree-programmable) Parameters 62-63
  - Factory setting 115
  - Fault indication
    - Output 10
  - Frequency
    - Current frequency 35
    - Rated frequency 50
  - Frequency limitation
    - Display 64
  - Frequency-dependent switch
    - Output 10
  - FUNCT-Key 16
- G
  - Global parameters 62
- H
  - H(andle) Parameters 42-46
  - Hour counter 35
- I
  - I(nformation) Parameters 64-65
  - Input
    - Function 45
    - Logic 44
    - Triggering 45
  - Inputs
    - Analog 11
    - Digital 6, 7, 82
    - Programmable 82
- Inverter address 54
- Inverter type 64
- K
  - Keyboard 4a
- L
  - L(evel) Parameters 47-49
  - LA-Stop 87
  - LD stop 87
    - DC voltage level 41
- Load
  - Current inverter utilization 33
  - Level 47
  - Peak load 33, 34
- Logic
  - Output logic 43
- M
  - Malfunction code 66
  - Modulation 96
    - Frequency 55
    - Lower limit 50
    - Select mode 55, 96
  - Motor data 51
    - Adjustment 94
  - Motor protection
    - Electronic 40
  - Motor protective function 92
  - Motor terminal resistance 51
- N
  - Noise filter
    - Analog inputs 57
    - Digital inputs 53
  - NPN/PNP 4b
- O
  - o(peration) Parameters 36-38
  - OL warning signal 48
  - Operation
    - Fundamentals 16
  - Operator level 17
  - Output
    - Analog 13, 44, 46, 80
    - Digital 9, 78
    - Logic 43
    - Out1...3-function 43
    - Switching hysteresis 57
    - Voltage stabilization 54
- Overload
  - Warning signal 10, 48
- P
  - P(rotection) Parameters 39-41
  - Parameter group
    - Selection 35
  - Parameter set
    - Activation 21
    - Display 21
    - Lock 58
  - Parameter set no.
    - Bus 63
    - Keyboard 62
  - Parameter set

- Programming 62/63
  - Selection 21, 26, 35
  - Shift mode 46
- Parameter set selection
  - Keyboard 7
- Parameter sets
  - Programming flow chart 102
- Parameterizing level 17
- Parameters
  - C- 52-58
  - c- 59-61
  - Communication 106
    - d- 50-51
  - Dependent on user-definition 97
  - ENTER 18
  - F- 62-63
  - Global 62
  - Group lock 54
  - Groups 17
  - H- 42-46
  - I- 64-65
  - L- 47-49
  - o- 36-38
  - P- 39-41
  - Pr- 66-68
  - r- 33-35
  - Set-programmable 22
  - Sets 21
  - Summary 32
  - Value 17
- Password
  - Input 35
  - Structure 20
  - Value 119
- Peak value Resetting 19
- PNP/NPN 4b
- Power off 59-61
  - Function 99
- Power off-function 59, 60, 61, 99
  - Adjustment 101
- Pr(ofile) Parameters 66-68
- Presetting 115
- Presetting reference value
  - Analog 12
  - Digital 25, 26
  - in percent 35
  - Input source 37
  - Keyboard 35
- R
  - r(un)-Parameter 33-35
- Ramp setting 28, 76
- Ramp stop 87
  - Activation 41
  - Current level 39
  - Hardware 87
  - Terminal strip 8
- Rated current
  - Display 64
  - Rated inverter current see Part 1
  - Rated motor current 51
- Rated frequency 50
  - Rated motor frequency 51
- Rated inverter current
  - Display 64
- Rated motor current 51
- Rated power factor
  - Rated motor  $\cos \varphi$  51
- Reference input 12
  - Adding 12
  - Second 12
- Reference value 70
  - Display 33
  - Limit 27, 52
  - Logic 42
  - min/max 36
  - MIN/MAX-value 67
  - Nominal-speed value 66
  - Offset 56, 73
  - Percentage 68
  - Presetting mode 42
  - Zero clamp speed 54
- Reference variable
  - Percentage 68
- Regulator
  - Adjustment 94
  - Optimization 95
  - Selection 59
- Reset 7
  - Automatic retry 40
  - by Bus 112
- Resonance frequency skipping 49
  - see Setting prohibition 49
- Rotation setting
  - Digital 25, 26
  - Input source 37, 53
  - Keyboard 7, 35
- RS232-Interface 103
- S
  - S-Curves 29, 38
  - Serial interface 4a, 103
  - Set lock 58
  - Setting prohibition 49
  - Slip compensation 94
    - Activation 59
    - Frequency gain 51
    - Voltage gain 51
- Software
  - Date 65
  - Identification 65
  - Version 33
- Speed
  - Speed Reference variable 67
  - Speed Search 90
    - Activation 40
    - Mode 41
- Stall function 88
- Starting
  - Hardware 14
- State diagram 112
- Status
  - Display 33
  - Input terminals 34
  - Output terminals 34
- Status messages 114
- Status word 66, 112
- Surveillance time 56
- Switching hysteresis 57
- T
  - Temperature
    - Heat sink 35
    - Heat sink/Warning level 41
- U
  - U/f function 39
- UP-Key 16
- V
  - Vertex
    - Max. carrier frequency 56
    - Min. carrier frequency 55
- Voltage
  - Intermediate circuit voltage 33
  - Output voltage 33
- W
  - Watchdog time 56
- Z
  - Zero clamp speed 55

Prior to delivery all products pass several quality and performance inspections so that malfunctions can be ruled out. When used in accordance with the operating instructions failure is most unlikely.

However, if you have cause for complaint the unit should be returned stating invoice number, delivery date, cause of failure and field conditions. We do not accept the responsibility for failures due to misuse, wrong storage or similar causes.

Leaflets, catalogues and quotations contain only standard values.

We reserve the right to make technical changes without obligation.

All rights reserved.

Any piratic printing, mimeographing or photomechanical reproduction, even in extracts, is strictly prohibited.



Karl E. Brinkmann GmbH  
Postfach 11 09 • Försterweg 36 - 38  
D - 32677 Bartrup • Telefon 0 52 63 / 4 01-0  
Teletex 5 263 811 keb • Telefax 4 01 - 116