

SMM

SERVO MOTORS

MADE
IN
GERMANY



Modular drive system: **KEB Servo** motor

KEB **Servo** motor describes the actual program of the closed-loop synchronous motors with special suitability for all dynamic drive tasks.

Efficient drive systems result in combination with the servo inverter series **KEB COMBIVERT F5** which can be optimally preset by web-based system configuration.

Complete solutions for different requirements in machine and plant engineering result in addition with the proper encoder system for the application, optional **KEB** holding brake and a mechanical adaption of torque/speed characteristic by different gear boxes.

Pre-assembled cables form ready for connection systems and are the base for a simple installation, fast start-up and trouble-free operation.

Table of contents	
Modular drive systems	2
Synchronous motors	3
Dynamic Line I	
... Properties	4
... Technical data	5
Dynamic Line II	
... Properties	6
... Technical data	7
Dimensions	
... Dynamic Line I	8
... Dynamic Line II	8
Planet gear SG AL	
The economic gear in compact design	10
Allocation table	11
Companies	12

Synchronous motors

are ideal drives for dynamic movements and offer in comparison to robust asynchronous drives significant lower mass inertia and high pulse torque.

Equipped with resolver or high-resolution SinCos encoders inclusive absolute information and electronic type plate, two series are available with up to 500% overload for all systems of rotating applications.

Synchronous motors offer a great energy optimization in machines and systems with efficiencies clearly above 95%.

DYNAMIC LINE I 0,2... 70 Nm

the approved series for general mechanical engineering

- ribbed surface with high thermal reserves
- lateral connections for encoder system and power

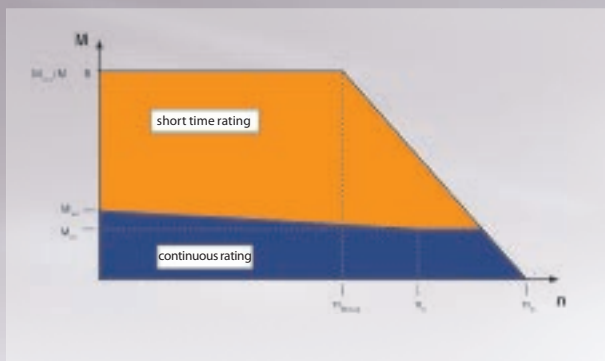

DYNAMIC LINE II 0,5... 50 Nm

by latest manufacturing technology increased component packaging density for special compact requirements in robotics, handling, bearing technology ...

- smooth housing surface
- parallel power and encoder connections



DYNAMIC LINE I - Synchronous servo motors SM.0

Servo motors of the series **SM.0** are permanent-field, electronic commutated synchronous motors for applications with highest requirements at simultaneously small unit volume and weight. 6-pole motors with NdFeB permanent magnets and three-phase winding for sine commutation captivate through impressed dynamics and a compact design.

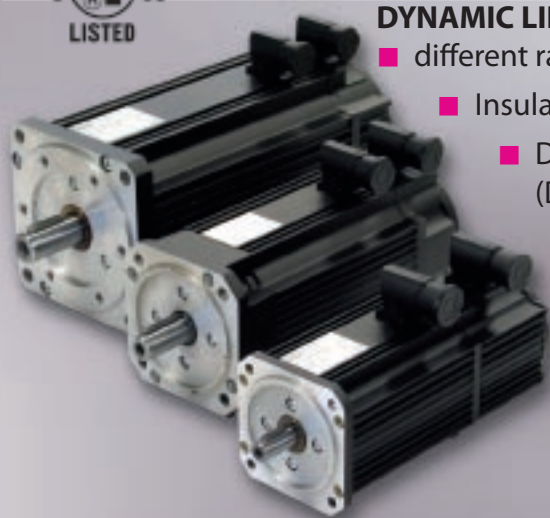

DYNAMIC LINE I - motors are available with

- different rated speed
- Insulation class F
- Degree of protection IP65 (DIN EN 60034-5)
- Resolver or
- high-resolution Hiperface- / Endat- / SSI encoder

Rotating connection socket for power and feedback are general standards.



55 mm



70 mm



92 mm



110 mm



140 mm



190 mm

Motor size	M _N [Nm]
A1.SM	0.32
A2.SM	0.48
A3.SM	0.6
A4.SM	0.8
B1.SM	0.6
B2.SM	0.5
B3.SM	1.3
B3.SM	1.0
B3.SM	2.0
B3.SM	1.5
C1.SM	0.8
C1.SM	0.75
C1.SM	0.7
C2.SM	2.4
C2.SM	2.2
C2.SM	2.0
C3.SM	3.9
C3.SM	3.5
C3.SM	2.8
C4.SM	5.0
C4.SM	4.5
C4.SM	3.0
D1.SM	3.7/5.5
D1.SM	3.5/5.1
D1.SM	3.0/4.2
D2.SM	6.1/8.7
D2.SM	5.8/8.4
D2.SM	3.8/7.5
D3.SM	8.4/12.2
D3.SM	7.6/12.0
D3.SM	5.0/10.5
D4.SM	9.9/15.6
D4.SM	8.6/15.5
E1.SM	7.0/11.2
E1.SM	6.5/10.3
E1.SM	5.2/9.3
E2.SM	12.2/18.7
E2.SM	11.0/17.1
E2.SM	7.6/15.5
E3.SM	16.5/26.0
E3.SM	14.6/23.8
E3.SM	8.7/21.6
E4.SM	21.4/33.0
E4.SM	15.5/31.6
F1.SM	22.5/35.4
F1.SM	21.5/35.0
F1.SM	20.0/31.7
F1.SM	16.0/28.0
F2.SM	42.0/64.0
F2.SM	38.0/63.0
F2.SM	31.0/58.2
F3.SM	61.0/92.8
F3.SM	52.0/90.0
F3.SM	33.0/85.0

Properties

- thermal winding protection with PTC thermistor 140°C
- Shaft end with keyway
- Vibration severity grade B according to EN 60034-14
- Half-key balancing according to DIN ISO 8821 with keyway
- Flange accuracy of the grade N according to DIN 42955
- Radial groove ball bearing with high temperature resistant special grease and lifetime lubrication
- Rating designed for operating mode S1
- Ambient temperature range of -20 to +40°C
- site altitude 1000m above sea level no derating

Options

- **KEB** holding brake
- Built-on gearbox
- Special shaft
- External ventilation

M ₀ [Nm]	M _{max} [Nm]	n _N [rpm]	n _{max} [rpm]	J _L [kgcm ²]	400 V				230 V			
					I _{N/400V} [A]	I _{0/400V} [A]	I _{max/400V} [A]	** recommended controller size	I _{N/200V} [A]	I _{0/200V} [A]	I _{max/200V} [A]	** recommended controller size
0.34	1.7	6,000	9,000	0.17	0.8	0.85	5.0	07.	1.0	1.2	7.1	05.
0.5	2.5	6,000	9,000	0.24	0.9	1.0	6.0	07.	1.5	1.5	9.0	05.
0.65	3.2	6,000	9,000	0.31	1.1	1.2	6.5	07.	2.0	2.0	10.8	07.
1.0	5.0	6,000	9,000	0.45	1.4	1.6	8.5	07.	2.9	3.2	17.0	07.
0.65	3.1	4,000	9,000	0.22	0.9	0.9	5.4	07.	2.0	1.9	11.4	07.
	3.1	6,000	9,000	0.22	1.2	1.3	7.8	07.	2.5	2.6	15.6	07.
1.5	7.2	4,000	9,000	0.36	1.4	1.6	9.6	07.	2.9	3.2	19.2	07.
	7.2	6,000	9,000	0.36	2.1	2.4	14.4	09.	4.4	5.0	30.0	09.
2.3	11.0	4,000	9,000	0.57	2.0	2.4	14.4	07.	4.7	5.5	33.0	10.
	11.0	6,000	9,000	0.57	3.0	3.5	21.0	09.	6.6	7.7	46.2	12.
0.95	4.3	3,000	6,000	1.2	0.75	0.8	4.0	07.	1.4	1.5	7.5	05.
		4,000	6,000	1.2	0.9	1.1	5.4	07.	1.8	2.0	10.0	05.
		6,000	6,000	1.2	1.3	1.6	8.0	07.	2.4	3.0	15.0	07.
		3,000	6,000	2.7	1.8	1.9	9.4	07.	3.0	3.2	16.0	07.
2.7	12.2	4,000	6,000	2.7	2.1	2.5	12.4	09.	3.6	4.3	21.5	09.
		6,000	6,000	2.7	3.0	3.7	18.5	09.	5.3	6.5	32.5	10.
		3,000	6,000	4.2	2.7	2.9	14.5	09.	4.6	5.1	25.5	09.
4.5	20.3	4,000	6,000	4.2	3.1	3.8	19.0	09.	5.5	6.7	33.4	10.
		6,000	6,000	4.2	3.8	5.6	27.9	10.	6.7	9.9	49.5	10.
		3,000	6,000	5.4	3.7	4.2	21.0	10.	6.3	7.1	35.5	10.
6.0	27.0	4,000	6,000	5.4	4.4	5.5	27.5	12.	7.3	9.1	45.5	12.
		6,000	6,000	5.4	4.5	7.8	39.0	12.	7.9	13.7	68.4	12.
4.2/6.2	18.9	3,000	6,000	4.8	2.8/4.2	3.0/4.1	14.4	09./12.	4.9/-	5.3/-	25.4/-	09.
		4,000	6,000	4.8	3.5/5.0	4.0/5.4	19.2	10./12.	6.1/-	7.0/-	33.6/-	10.
		6,000	6,000	4.8	4.8/6.7	6.0/8.1	28.8	12./13.	8.2/-	10.2/-	48.9/-	12.
		3,000	6,000	7.4	4.5/6.4	4.8/6.8	23.0	12./13.	8.1/-	8.5/-	40.8/-	12.
7.0/10.5	31.5	4,000	6,000	7.4	5.8/8.4	6.4/9.2	30.7	12./14.	10.5/-	11.6/-	55.7/-	12.
		6,000	6,000	7.4	5.9/11.7	9.9/14.2	47.5	13./15.	9.6/-	16.0/-	76.8/-	12.
		3,000	6,000	9.8	6.3/9.2	7.2/10.4	34.5	12./14.	10.9/-	12.4/-	59.5/-	12.
10.0/14.5	45.0	4,000	6,000	9.8	7.7/12.2	9.7/14.1	46.5	13./15.	13.5/-	17.0/-	81.6/-	13.
		6,000	6,000	9.8	7.6/16.0	13.6/19.7	65.3	14./16.	12.7/-	22.6/-	108.0/-	13.
		3,000	6,000	12.7	7.3/11.5	8.5/12.3	40.8	13./15.	12.2/-	14.2/-	68.1/-	13.
12/18.0	54.0	4,000	6,000	12.7	8.6/14.7	11.6/16.8	55.7	13./16.	13.5/-	18.2/-	87.3/-	13.
8.5/12.9	42	2,000	4,000	12.3	2.6/4.2	3.1/4.7	16	09./12.	4.4/-	5.3/-	28/-	09.
		3,000	4,000	12.3	3.8/5.9	4.7/7.1	25	10./12.	6.4/-	8.0/-	42/-	10.
		4,000	4,000	12.3	4.0/7.2	6.2/9.3	33	12./13.	6.9/-	10.7/-	57/-	12.
		2,000	4,000	19.5	4.1/6.3	4.7/6.5	25	10./12.	7.5/-	8.6/-	46/-	12.
14/21.5	70	3,000	4,000	19.5	5.8/9.1	7.5/9.7	40	12./14.	10.4/-	13.3/-	71/-	12.
		4,000	4,000	19.5	5.4/11.1	10.0/12.7	53	13./15.	9.7/-	17.8/-	94/-	13.
		2,000	4,000	26.7	6.1/9.6	6.8/10.7	33	12./14.	10.6/-	11.7/-	56/-	12.
19/30	85	3,000	4,000	26.7	8.3/13.4	10.3/16.3	49	13./15.	14.0/-	17.6/-	84/-	13.
		4,000	4,000	26.7	6.4/15.9	13.5/21.3	65	14./16.	10.4/-	21.9/-	105/-	13.
		2,000	3,000	36.0	7.8/12.1	9.9/12.7	47	13./15.	13.0/-	16.5/-	79/-	13.
27/42	121	3,000	3,000	36.0	8.3/16.8	14.4/18.5	69	15./16.	13.3/-	23.2/-	111/-	13.
		1,500	4,000	84.0	7.5/11.8	8.2/12.3	29	13./15.				
		2,000	4,000	84.0	9.7/15.8	11.1/16.6	39	14./16.				
25/39	88	3,000	4,000	84.0	13.8/21.9	17.0/25.4	60	15./17.				
		4,000	4,000	84.0	14.8/25.5	22.2/33.2	78	16./18.				
		1,500	4,000	147	14.5/22.1	17.0/25.5	60	16./17.				
50/75	175	2,000	4,000	147	17.2/28.5	22.3/33.5	78	16./19.				
		3,000	4,000	147	20.6/38.7	32.2/48.3	113	17./20.				
		1,500	4,000	210	20.9/31.8	23.1/34.8	81	17./19.				
70/110	245	2,000	4,000	210	23.7/41.1	30.8/46.0	108	17./20.				
		3,000	4,000	210	22.9/56.0	46.2/69.0	162	17./22.				

■ with external ventilation

** recommended controller size F5-M/-S for M_{max} = approx. 2,5xM_N

DYNAMIC LINE II - Synchronous servo motors SM.5

The new synchronous motors **DYNAMIC LINE II** are characterised by increased packaging density and thereby especially predestinated for tasks with special requirements on size/volume and weight.

UL listed motors are characterised by small inertia and high overload torque and they are available alternatively also with **KEB** brake. Parallel arranged and rotating plug connections for power and position offer universal application in the mechanics. In addition to the basic version with resolver feedbacks, BISS encoder are available in single- and multiturn version.



Together with preassembled cables and the electronic type plate there is a minimum start-up time. The complete solution reduces the assembly error potential and secures high availability and best service.

Properties

- thermal winding protection with PTC thermistor 150°C
- smooth shaft end
- Vibration severity grade B according to EN 60034-14
- Degree of protection IP65 (shaft seal IP64)
- Flange accuracy of the grade N according to DIN 42955
- Radial groove ball bearing with high temperature resistant special grease and lifetime lubrication
- Rating designed for operating mode S1
- Ambient temperature range of -20 to +40°C
- site altitude 1000m above sea level no derating

Options

- **KEB** holding brake
- Gear assembly
- Special shaft
- External ventilation
- Half-key balancing according to DIN ISO 8821 with keyway

Motor size

	A1.SM A2.SM A3.SM A4.SM
55 mm	B1.SM
	B2.SM
90 mm	B3.SM
	C1.SM C2.SM C3.SM
102 mm	C4.SM
	D1.SM D2.SM D3.SM
140 mm	D4.SM
	E1.SM E2.SM E3.SM
195 mm	

M _N [Nm]	M ₀ [Nm]	M _{max} [Nm]	n _N [rpm]	n _{max} [rpm]	J _L [kgcm ²]	400 V				230 V			
						I _{N / 400V} [A]	I _{0 / 400V} [A]	I _{max / 400V} [A]	**recommen- ded controller size	I _{N / 200V} [A]	I _{0 / 200V} [A]	I _{max / 200V} [A]	**recommen- ded controller size
0.43	0.47	2.1	6,000		0.13	0.93	0.94	4.5	07.	1.66	1.81	8.9	05.
0.62	0.66	2.9	6,000	9,000	0.18	1.16	1.24	5.6	07.	1.92	2.04	10.1	05.
0.80	0.87	3.8	6,000		0.23	1.44	1.43	6.9	07.	2.54	2.52	13.2	07.
1.05	1.14	5.0	6,000		0.34	1.64	1.55	8.0	07.	3.29	3.10	17.4	07.
0.90			3,000			1.0	1.0	3.6	07.	1.7	1.6	5.9	05.
0.87	0.92	2.7	4,000	9,000	0.30	1.2	1.2	4.5	07.	2.1	2.0	7.4	05.
0.76			6,000			1.3	1.5	5.5	07.	2.4	2.8	10.1	07.
1.83			3,000			1.7	1.6	6.1	07.	3.1	2.8	11.0	07.
1.75	1.8	5.4	4,000	9,000	0.56	2.1	2.0	7.7	07.	4.2	3.9	15.4	07.
1.5			6,000			2.3	2.5	9.9	09.	4.2	4.8	18.9	09.
2.6			3,000			2.6	2.3	9.2	09.	4.3	3.9	15.2	09.
2.5	2.6	7.8	4,000	9,000	0.79	2.9	2.7	10.8	09.	4.9	4.7	18.4	09.
2.3			6,000			3.6	3.9	15.5	09.	6.5	7.1	28.0	09.
3.8/5.2			2,000			2.5/3.3	2.5/3.2	8.4	09./09.	4.1	4.3	15.3	09.
3.5/4.7	3.9/5.0	12.0	3,000	6,000	2.7	2.8/3.8	3.1/4.0	10.5	09./10.	5.7	6.2	22.4	09.
3.1/4.2			4,000			3.1/4.2	3.9/5.0	13.2	09./10.	6.2	7.7	27.6	09.
5.5/7.4			2,000			3.7/4.9	3.8/4.9	12.6	09./10.	5.8	6.2	14.8	09.
4.8/6.4	5.7/7.4	17.5	3,000	6,000	3.7	4.2/5.7	5.0/6.5	16.8	10./12.	7.1	8.8	30.6	10.
4.2/5.6			4,000			4.5/6.1	6.1/7.9	20.4	12./12.	8.4	11.7	40.8	12.
6.9/9.3			2,000			4.3/5.8	5.7/7.4	16.2	12./12.	6.8	8.9	25.5	10.
6.4/8.6	7.1/9.2	22.0	3,000	6,000	4.7	4.9/6.7	7.0/9.1	20.0	12./12.	9.6	13.8	39.4	10.
5.7/7.7			4,000			5.5/7.5	8.8/11.4	25.1	12./13.	10.8	17.3	49.3	12.
8.3/11.2			2,000			4.2/5.7	5.5/7.1	15.3	10./12.	8.1	8.8	29.7	10.
7.6/10.3	8.5/11.1	26.0	3,000	6,000	6.0	6.0/8.0	8.5/11.0	23.8	12./13.	10.8	12.9	43.5	12.
6.8/9.2			4,000			6.6/8.9	10.7/13.7	29.6	12./14.	11.9	16.1	54.4	12.
8.0/10.8			1,500			3.3/4.4	3.6/4.7	12.1	10./10.				
7.6/10.3	8.2/10.6	25.0	2,000	4,500	7.9	4.0/5.4	4.6/6.0	15.5	10./12.				
6.8/9.1			3,000			4.6/6.2	6.0/7.9	20.1	12./12.				
11.5/15.6			1,500			5.1/6.9	5.6/7.3	19.0	12./12.				
11.0/14.9	11.6/15.1	36.0	2,000	4,500	11.2	6.0/8.1	6.9/9.0	23.3	12./12.				
9.5/12.8			3,000			6.7/9.1	8.9/11.6	30.1	12./13.				
15.0/20.2			1,500			6.1/8.2	6.8/8.8	22.7	12./12.				
14.0/18.9	18.4/19.9	47.0	2,000	4,500	14.4	7.3/9.9	8.8/11.4	29.4	13./13.				
11.9/16.1			3,000			8.0/10.9	11.2/14.6	37.7	13./14.				
18.0/24.3			1,500			7.4/9.9	8.2/10.7	27.2	12./13.				
16.0/22.8	18.4/23.9	57.0	2,000	4,500	19.5	8.8/11.9	10.4/13.6	35.3	13./14.				
13.4/18.5			3,000			9.6/12.9	14.0/18.2	47.4	14./15.				
23.0/30.0			1,000			6.9/9.3	7.6/9.9	23.3	12./14.				
19.0/28.0	23.5/30.6	65.0	2,000	4,000	57.0	9.7/14.4	12.7/17.1	39.3	13./15.				
14.0/24.0			3,000			9.4/16.6	16.9/22.8	52.2	14./15.				
34.0/45.0			1,000			9.8/13.3	10.9/14.4	36.3	09./14.				
28.0/40.0	35./45.5	106.0	2,000	4,000	79.0	14.2/21.0	19.3/25.5	64.1	15./16.				
19.0/34.0			3,000			12.4/22.3	24.8/32.5	81.7	14./16.				
47.0/62.0			1,000			14.5/19.9	16.1/21.4	53.2	14./15.				
40.0/57.0	48.0/62.5	145.0	2,000	4,000	102	20.8/30.8	27.7/36.9	90.4	16./17.				
27.0/48.0			3,000			19.6/36.2	38.2/51.6	127.0	16./18.				

■ with external ventilation

** recommended controller size F5-M/-S for M_{max} = approx. 2,0 x M_N

DYNAMIC LINE I SM.0

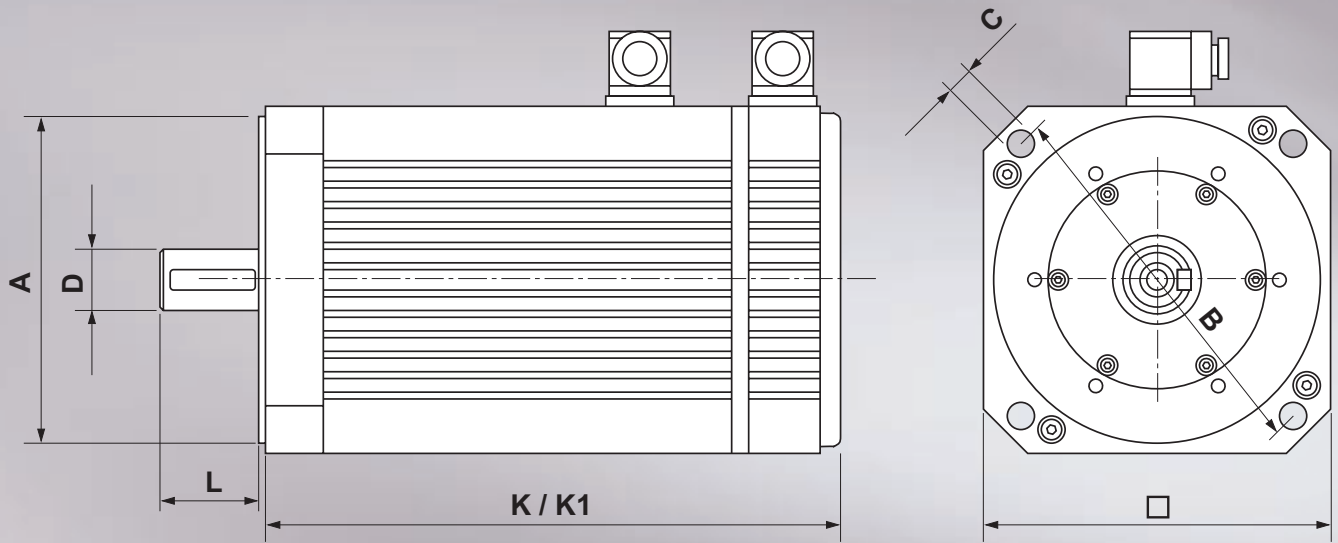

DYNAMIC LINE II SM.5

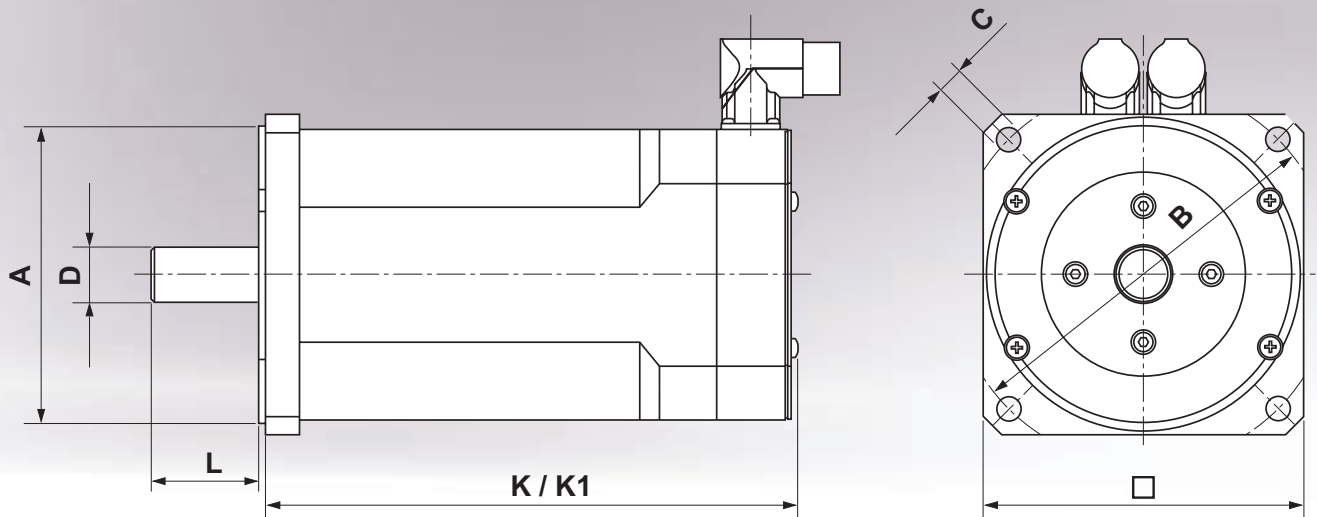

Motor size	□	Ø A	Ø B	Ø C	Ø D	K	L	m	K1	Data permanent-magnet brake *													
										Dimensions				Motor	Brake	$M_{\text{Brake (static)}}$	J_{Brake}	n_{max}	U_{rated}	I_{rated}	t_1	t_2	Type
										[mm]				[kg]	[kg]	[Nm]	[kgcm ²]	[rpm]	[V]	[A]	[ms]	[ms]	
A1.SM		40	63	5.8	9	121		1.0	0.18	145	2	0.068	9,000	24	0.46	6	25	03.P1					
A2.SM	55	40	63	5.8	9	133	20	1.2	0.18	157	2	0.068	9,000	24	0.46	6	25	03.P1					
A3.SM		40	63	5.8	9	145		1.4	0.18	169	2	0.068	9,000	24	0.46	6	25	03.P1					
A4.SM		40	63	5.8	9	170		1.8	0.18	194	2	0.068	9,000	24	0.46	6	25	03.P1					
B1.SM		60	75	5.8	11	136		1.5	0.30	164	4.5	0.18	9,000	24	0.50	7	35	05.P1					
B2.SM	70	60	75	5.8	11	160	23	2.1	0.30	188	4.5	0.18	9,000	24	0.50	7	35	05.P1					
B3.SM		60	75	5.8	11	196		2.9	0.30	223	4.5	0.18	9,000	24	0.50	7	35	05.P1					
C1.SM		80	100	7	14	156		2.7	0.50	202	9	0.6	6,000	24	0.75	7	40	06.P1					
C2.SM		80	100	7	14	180	30	3.9	0.50	226	9	0.6	6,000	24	0.75	7	40	06.P1					
C3.SM	92	80	100	7	14	214		5.2	0.50	260	9	0.6	6,000	24	0.75	7	40	06.P1					
C4.SM		80	100	7	14	248		6.6	0.50	294	9	0.6	6,000	24	0.75	7	40	06.P1					
D1.SM		95	115	9	19	218		6.3	0.78	226	11	2.3	6,000	24	0.84	22	90	08.P1					
D2.SM	110	95	115	9	19	248	40	7.9	0.78	56	11	2.3	6,000	24	0.84	22	90	08.P1					
D3.SM		95	115	9	19	278		9.6	0.78	286	11	2.3	6,000	24	0.84	22	90	08.P1					
D4.SM		95	115	9	19	308		11.2	0.78	316	11	2.3	6,000	24	0.84	22	90	08.P1					
E1.SM		130	165	11	24	231		10.2	1.63	276	36	5.9	4,000	24	1.1	22	90	08.P1					
E2.SM	140	130	165	11	24	261	50	12.3	1.63	306	36	5.9	4,000	24	1.1	22	90	08.P1					
E3.SM		130	165	11	24	291		15.5	1.63	336	36	5.9	4,000	24	1.1	22	90	08.P1					
F1.SM		180	215	14	32	348		30.5	3.80	348	85	17.6	4,000	24	1.5	25	140	09.P1					
F2.SM	190	180	215	14	32	428	50	44.0	3.80	428	85	17.6	4,000	24	1.5	25	140	09.P1					
F3.SM		180	215	14	32	508		57.5	3.80	508	85	17.6	4,000	24	1.5	25	140	09.P1					

Motor size	□	Ø A	Ø B	Ø C	Ø D	K	L	m	K1	Data permanent-magnet brake *													
										Dimensions				Motor	Brake	$M_{\text{Brake (static)}}$	J_{Brake}	n_{max}	U_{rated}	I_{rated}	t_1	t_2	Type
										[mm]				[kg]	[kg]	[Nm]	[kgcm ²]	[rpm]	[V]	[A]	[ms]	[ms]	
A1.SM		40	63	5.8	9	121		1.0	0.18	145	2	0.070	9,000	24	0.46	6	18	03.P1					
A2.SM	55	40	63	5.8	9	133	20	1.2	0.18	157	2	0.070	9,000	24	0.46	6	18	03.P1					
A3.SM		40	63	5.8	9	145		1.4	0.18	169	2	0.070	9,000	24	0.46	6	18	03.P1					
A4.SM		40	63	5.8	9	170		1.9	0.18	194	2	0.070	9,000	24	0.46	6	18	03.P1					
B1.SM		80	100	7	14	132		2.3	0.28	164	4.5	0.18	9,000	24	0.58	7	25	05.P1					
B2.SM	90	80	100	7	14	158	30	3.0	0.28	190	4.5	0.18	9,000	24	0.58	7	25	05.P1					
B3.SM		80	100	7	14	184		3.7	0.28	216	4.5	0.18	9,000	24	0.58	7	25	05.P1					
C1.SM		95	115	9	19	178		4.8	0.57	214	10	1.01	6,000	24	0.71	7	25	06.P1					
C2.SM	102	95	115	9	19	206	40	6.3	0.57	242	10	1.01	6,000	24	0.71	7	25	06.P1					
C3.SM		95	115	9	19	234		7.4	0.57	270	10	1.01	6,000	24	0.71	7	25	06.P1					
C4.SM		95	115	9	19	262		8.6	0.57	298	10	1.01	6,000	24	0.71	7	25	06.P1					
D1.SM		130	165	11	24	203		10.0	1.15	237	22	2.76	6,000	24	0.84	22	70	07.P1					
D2.SM	140	130	165	11	24	233	50	11.9	1.15	267	22	2.76	6,000	24	0.84	22	70	07.P1					
D3.SM		130	165	11	24	263		14.0	1.15	297	22	2.76	6,000	24	0.84	22	70	07.P1					
D4.SM		130	165	11	24	293		18.0	1.15	327	22	2.76	6,000	24	0.84	22	70	07.P1					
E1.SM		180	215	14	32	266		24.0	3.40	300	60	20.1	4,000	24	2.3	50	130	09.P1					
E2.SM	195	180	215	14	32	294	58	26.0	3.40	328	60	20.1	4,000	24	2.3	50	130	09.P1					
E3.SM		180	215	14	32	322		29.0	3.40	356	60	20.1	4,000	24	2.3	50	130	09.P1					

* all technical data with 20 °C

PLANET GEAR SG.AL

The gears of the series **SG.AL** offer the designer a compact, economic and precise conversion of speed and torque in the machine.

The design contains actual 4 sizes in 1 - and 2-step structure with rated output torque upto 100 Nm. The large reduction range permits an optimal adaption of motor and speed.

- high reliability and high overload security in series
- large gear ratio $i = 3 \dots 100$
- lifetime lubrication, maintenance-free
- small operating noises
- optimal efficiency $> 95 \%$
- output shaft with featherkey
- simple, direct motor connection, applicable for

DYNAMIC Line I and II



The economic gear in compact design!

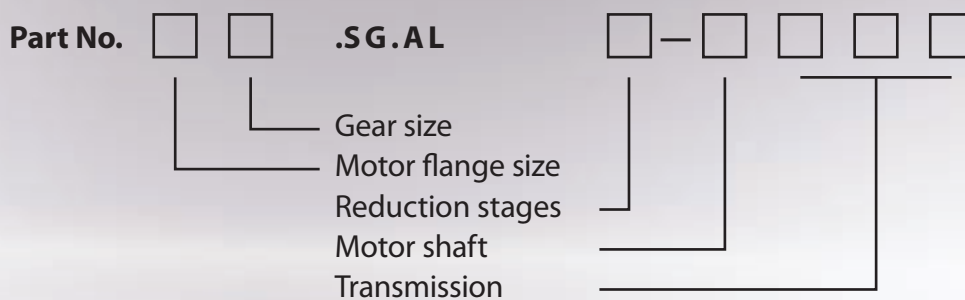

Planet gears **SG.AL** AL with hardened, integrated gearing, high strength and precision at minimum dimensions offer furthermore:

Universal motor connection

to **DYNAMIC LINE** motors **I** and **II** with prepared motor flanges and clamping hubs.

Maintenance-free operation

by lifetime grease packing means: no service necessary!

Balanced properties

by precise, simple design mean good torsional backlash quality at smallest costs.

Reinforced output bearing

designed for high axial and radial force at small mounting location.

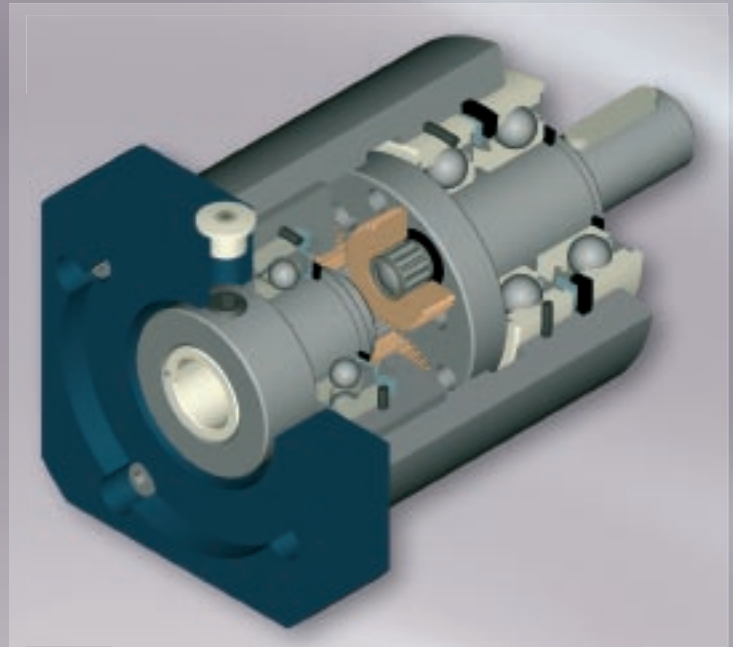

Mechanical allocation table servomotors / planetary gear

Motor sizes					Gear sizes			
Dynamic Line I	Flange Ø	Shaft	Hole circle Ø	Recess Ø				
A1 .. A4. SM.	55	9 x 20	63	40	A1.SG.AL	—	—	—
B1 .. B3. SM.0	70	11 x 23	75	60	B1.SG.AL	B2.SG.AL	—	—
C1 .. C4. SM.0	92	14 x 27	100	80	—	C2.SG.AL	C3.SG.AL	—
D1 .. D4. SM.0	110	19 x 30	115	95	—	—	D3.SG.AL	D4.SG.AL
E1 .. E4. SM.0	140	24 x 50	165	130	—	—	—	E4.SG.AL
Dynamic Line II	Flange Ø	Shaft	Hole circle Ø	Recess Ø				
A1 .. A4. SM.	55	9 x 20	63	40	A1.SG.AL	—	—	—
B1 .. B3. SM.0	90	14 x 23	100	80	—	C2.SG.AL	C3.SG.AL	—
C1 .. C4. SM.0	102	19 x 30	115	95	—	—	D3.SG.AL	D4.SG.AL
D1 .. D4. SM.0	140	24 x 40	165	130	—	—	—	E4.SG.AL

[Measures in mm]

Headquarters

Karl E. Brinkmann GmbH
Försterweg 36 - 38
D-32683 Barntrup
Internet: www.keb.de

Tel.: +49 (0) 5263 401-0
Fax: +49 (0) 5263 401-116
E-mail: info@keb.de

SUBSIDIARIES

AUSTRIA

KEB Antriebstechnik
Austria GmbH
Ritzstraße 8
A - 4614 Marchtrenk
Tel.: +43 (0)7243 53586-0
Fax: +43 (0)7243 53586-21
E-mail: info@keb.at
Internet: www.keb.at

CHINA

KEB Power Transmission
Technology (Shanghai) Co. Ltd.
No. 435 QuianPu Road
Songjiang East Industrial Zone
CN-201611 Shanghai, PR. China
Tel.: +86 (0)21 37746688
Fax: +86 (0)21 37746600
E-mail: info@keb.cn
Internet: www.keb.cn

GERMANY

KEB Antriebstechnik GmbH
Wildbacher Straße 5
D-08289 Schneeberg
Tel.: +49 (0)3772 67-0
Fax: +49 (0)3772 67-281
E-mail: info@keb-combidrive.de

FRANCE

Société Française KEB
Z.I. de la Croix St. Nicolas
14, rue Gustave Eiffel
F - 94510 LA QUEUE EN BRIE
Tel.: +33 (0)149620101
Fax: +33 (0)145767495
E-mail: info@keb.fr
Internet: www.keb.fr

GREAT BRITAIN

KEB (UK) Ltd.
6 Chieftain Business Park,
Morris Close
Park Farm, Wellingborough
GB - Northants, NN8 6 XF
Tel.: +44 (0)1933 402220
Fax: +44 (0)1933 400724
E-mail: info@keb-uk.co.uk
Internet: www.keb-uk.co.uk

ITALY

KEB Italia S.r.l. Unipersonale
Via Newton, 2
I - 20019 Settimo Milanese (Milano)
Tel.: +39 02 33535311
Fax: +39 02 33500790
E-mail: info@keb.it
Internet: www.keb.it

JAPAN

KEB - Japan Ltd.
15 - 16, 2 - Chome
Takanawa Minato-ku
J - Tokyo 108 - 0074
Tel.: +81 (0)33 445-8515
Fax: +81 (0)33 445-8215
E-mail: info@keb.jp
Internet: www.keb.jp

RUSSIA

KEB RUS Ltd.
Lesnaya str, house 30
Dzerzhinsky (MO)
RUS - 140091 Moscow region
Tel.: +7 (0)495 5508367
Fax: +7 (0)495 6320217
E-mail: info@keb.ru
Internet: www.keb.ru

USA

KEB America, Inc
5100 Valley Industrial
Blvd. South
USA - Shakopee, MN 55379
Tel.: +1 952 2241400
Fax: +1 952 2241499
E-mail: info@kebameric.com
Internet: www.kebameric.com

Representative offices in Belgium • Korea • Spain • Sweden

Further partners in ...

Australia • Belgium • Bolivia • Brazil • Chile • Czech Republic • Denmark • Egypt • Greece • Hungary • India • Indonesia • Iran • Israel • Kazakhstan • Malaysia • Morocco • Netherlands • New Zealand • Pakistan • Poland • Portugal • Romania • Singapore • Slovakia • South Africa • Spain • Sweden • Switzerland • Taiwan • Thailand • Tunisia • Turkey • Ukraine • Uzbekistan

... under www.keb.de/en/contact/keb-worldwide.html



© KEB 00.00.000-5DSM / 05-2010 • Technical subject to alteration!

