

COMBIVERT



R6

Ⓒ INSTRUCTION MANUAL

Type R6-S

Power supply and
regenerative unit
Size 29

Mat.No.	Rev.
00R6SEB-KP00	1C

KEB

GB

This instruction manual describes the power supply and recovery unit KEB COMBIVERT R6-S. Before working with the unit the user must become familiar with it. This especially applies to the knowledge and observance of the following safety and warning indications. The pictographs used in this instruction manual have following meaning:



Danger
Warning
Caution



Attention
Essential Mea-
sure



Information
Help
Tip

1. Introduction.....	4
1.1 Preface.....	4
1.2 Product Description.....	4
1.3 Specified Application	5
1.3.1 Standard operation	5
1.3.2 Abnormal operation.....	5
1.4 Unit identification.....	5
2. Safety Instructions	6
2.1 General instructions	6
2.2 Transport, Storage and Installation.....	6
2.3 Electrical connection.....	7
2.4 EMC instructions	10
2.5 EMC conform installation.....	10
3. Technical Data	11
3.1 Power data.....	11
3.2 Operating conditions.....	12
3.3 Accessories.....	13
3.4 Options	13
3.4.1 Ferrite rings.....	13
3.5 Dimensions and weights.....	14
3.5.1 Dimensions air-cooled inverter mounting version.....	14
3.5.2 Commutation-/mains choke	15
3.5.3 HF side-mounted filter.....	16
3.5.4 Synchronization unit.....	16
4. Installation.....	17
4.1 EMC-compatible control cabinet installation.....	17
4.2 Installation Instructions	17
4.3 Connection of the COMBIVERT R6	18
4.3.1 Connection terminals of the power circuit.....	18
4.3.2 External fan power supply.....	18
4.3.3 Connections of the control board.....	19
4.3.4 Connection of the synchronization unit.....	19
4.4 Connection Power Unit R6.....	20
4.4.1 Supply and regenerative operation at inverter current \leq current of one COMBIVERT R6-S.....	20
4.4.2 Supply and regenerative operation at inverter currents \leq current of one COMBIVERT R6-S	21
4.4.3 Supply and regenerative operation at parallel operation of two R6-S	22
4.5 Connection of the control board version S	25
4.5.1 Assignment of the control terminal strip X2A.....	25
4.5.2 Assignment of socket X2B	25
4.5.3 Wiring example	26
4.6 Operator.....	27
5. Operation of the Unit.....	28
5.1 Keyboard	28
5.2 Operation with PC und system software COMBIVIS	28
5.3 Switch-on procedure	28
5.4 Parameter summary	30
5.5 Password input	31
5.6 Monitoring- and analysis parameters	31
5.7 Special adjustments	35
A. Appendix	38
A.1 Dimensioning of power supply and regenerative units	38
A.2 DC link capacitors of KEB frequency inverters	39
A.3 Dimensioning of decoupling diodes.....	39

1. Introduction

1.1 Preface

First we would like to welcome you as a customer of the company Karl E. Brinkmann GmbH and congratulate to the purchase of this product. You have decided for a product on highest technical niveau.

The enclosed documents as well as the specified hard- and software are developments of the Karl E. Brinkmann GmbH. Errors excepted. The Karl E. Brinkmann GmbH has created these documents, this hard- and software with best the knowledge. We doesn't accept the guarantee that the user gets the profit with this specifications. The Karl E. Brinkmann GmbH reserves the right to change specifications without prior notice or to instruct third persons. This list is not exhaustive.

The used pictograms have following significance:



Danger
Warning
Caution



Attention
Essential
Discharge Time



Information
Help
Tip

1.2 Product Description

This instruction manual describes the power supply and recovery unit KEB COMBIVERT R6-S. The COMBIVERT R6-S has the following features.

The supply unit

- converts a three-phase input voltage into DC voltage.
- supplies KEB frequency inverter individually or via DC interconnection.
- can be switched parallel, if higher power supply is required.
- increases the stability of the DC link voltage in the DC interconnection.

The feedback unit

- feeds back the excess energy from generatoric operation into the supply system.
- reduces the energy demand.
- reduces the heat emission.
- is environmentally friendly and space-saving.
- replaces braking resistor and braking transistor.
- is cost-saving.

The COMBIVERT R6-S is generally protected against overcurrent, ground fault and temperature. Appropriate dimensioned DC fuses protects the DC link circuit against short-circuit. The following accessories are necessary for operation with the COMBIVERT R6-S:

- Power choke
- HF filter (for observance of EMC standard)

1.3 Specified Application

The COMBIVERT R6-S serves exclusively for the supply of frequency inverters with DC input and/or feedback of excess energy into the supply system. The operation of other electrical consumers is prohibited and can lead to malfunctions or to the destruction of the units.

1.3.1 Standard operation

If the DC link voltage increases to a value above the peak value of the mains voltage (negative power), feedback of the current into the mains occurs automatically. The mains voltage is analog measured. The feedback occurs in a square-wave format, whereby the current flow period corresponds to the times of a B6 bridge circuit. The feedback is finished if the DC link voltage decreases the supply peak voltage (positive power).

1.3.2 Abnormal operation

When exceeding the permissible limit values for voltage, current or temperature the current flow between DC link and mains is blocked during recovery. An appropriate error message is also displayed during supply. The unit must be disconnected from the supply system or the load must be switched off in case of overcurrent. This can be done by opening the control release of the frequency inverter.

At factory setting the modulation is switched off in case of a net phase and/or a synchronisation line failure and the error message E.nEt is displayed.

Special adjustments from KEB are necessary if the modulation and/or the standard operation should start again within a defined time in case of return of power supply.

1.4 Unit identification

29	R6	s	1	P	9	1	0	A	
				Type	A: Heat sink (standard)		D: External fan power supply		
				Design	0: default				
				reserved	0: default		1: modified default		
				Voltage	9: 3-ph.; 400 V; AC				
				Housing	P				
				Options	1: internal precharging				
				Control	S: 2B.R6				
				Series	R6				
				Unit size	29				

Safety Instructions

2. Safety Instructions

2.1 General instructions

 <p>Electric Shock</p>	<p>COMBIVERT R6 power supply and recovery units contain dangerous voltages which can cause death or serious injury.</p> <p>COMBIVERT R6 can be adjusted by way that energy is refeed into the supply system in case of power failure at generatoric operation. Therefore a dangerous high tension can exist in the unit after switching off the supply system.</p> <p>Before working with the unit check the isolation from supply by measurements in the unit.</p> <p>Care should be taken to ensure correct and safe operation to minimise risk to personnel and equipment.</p>
--	--

 <p>Only Qualified Electro-Personnel</p>	<p>All work from the transport, to installation and start-up as well as maintenance may only be done by qualified personnel (IEC 364 and/or CENELEC HD 384 and IEC-Report 664 and note national safety regulations). According to this manual qualified staff means those who are able to recognise and judge the possible dangers based on their technical training and experience and those with knowledge of the relevant standards and who are familiar with the field of power transmission.</p>
--	---

 <p>Observe Standards</p>	<p>The COMBIVERT R6 must not be started until it is determined that the installation complies with 2006/42/EC (machine directive) as well as the EMC directive (2004/108/EC) (note EN60204).</p> <p>The COMBIVERT R6 meets the requirements of the Low-Voltage Directive 2006/95/EC. The harmonized standard of the series EN 61800-5-1 (VDE 0160) is used.</p> <p>This is a product of limited availability in accordance with IEC 61800-3. This product may cause radio interference in residential areas. In this case the operator may need to take corresponding measures.</p>
--	---







2.2 Transport, Storage and Installation

The storage of the COMBIVERT must be done in the original packing. It is to be protected against humidity and excessive cooling and thermal effect. A long-distance transport must be carried out in the original packing. It is to be secured against impact influence. The marking on the final packing must be observed! After removing the final packing the COMBIVERT must be set down on a stable base.





 <p>Protect Against Accidental Contact</p>	<p>The COMBIVERT R6 must be protected against invalid loading. Especially, no components may be bent or isolating distances altered in the course of transportation or handling. The units contain electrostatically endangered components which can be destroyed by inappropriate handling. For that reason the contact of electronic components and contacts must be avoided. The equipment must not be switched on if it is damaged as it may no longer comply with mandatory standards.</p> <p>Make sure that during installation there is enough minimum clearance and enough cooling. Climatic conditions must be observed in accordance with the instruction manual.</p>
--	---

 <p>Hot Surface</p>	<p>Heat sinks can reach temperatures, which can cause burns when touching. If in case of structural measures a direct contact cannot be avoided, a warning notice "hot surface" must be mounted at the machine.</p>
---	---

2.3 Electrical connection

 Note Capacitor Discharge Time	<p>Before any installation and connection work, the system must be switched off and secured. After clearing the intermediate circuit capacitors are still charged with high voltage for a short period of time. The unit can be worked on again, after it has been switched off for 5 minutes.</p>											
 Secure Isolation	<p>The terminals of the control terminal strip are securely isolated in accordance with EN 61800-5-1. With existing or newly wired circuits the person installing the units or machines must ensure the EN requirements are met. With frequency inverters that are not isolated from the supply circuit all control lines must be included in other protective measures (e.g. double insulation or shielded, earthed and insulated).</p>											
 Voltage With Respect To Ground	<p>Connection of the COMBIVERT R6 is only permissible on symmetrical networks with a maximum line voltage (L1, L2, L3) with respect to earth (N/PE) of 305V. An isolating transformer must be used for supply networks which exceed this value! The units may be damaged if this is not observed.</p>											
 Earthed External Conductor	<p>The COMBIVERT R6 can be connected to power systems with earthed external conductors (e.g. delta power systems) if the following exceptions apply:</p> <ul style="list-style-type: none"> the control system is no longer regarded as "securely isolated circuit", further protection measures are therefore required with this type of power system, the max. voltage phase / earth must not exceed 528V absolute external DC fuses at the DC connections are necessary for the 400V class. Use the COMBIVERT R6-S without internal DC fuses. 											
 Stationary Connection	<p>The COMBIVERT R6 is designed for fixed connection only as discharge currents of > 3.5 mA may occur especially when using EMI filters. In accordance with EN 61800 - 5 - 1 the following cross sections of the protective earth conductor must be used:</p> <table border="1" data-bbox="427 1294 1513 1664"> <thead> <tr> <th>Cross-section of the phase conductors</th> <th>Minimum cross-section of the protective earth conductor</th> </tr> </thead> <tbody> <tr> <td rowspan="2"><10 mm²</td> <td>10 mm² CU or</td> </tr> <tr> <td>additional connection terminal for a second protective earth conductor with the same cross-section as the phase conductor</td> </tr> <tr> <td>10...16 mm²</td> <td>Protective earth conductor with cross-section as phase conductor</td> </tr> <tr> <td>16...35 mm²</td> <td>Protective earth conductor with a cross-section of 16 mm²</td> </tr> <tr> <td>>35 mm²</td> <td>Protective earth conductor with a cross-section of 50% of the phase conductor.</td> </tr> </tbody> </table>	Cross-section of the phase conductors	Minimum cross-section of the protective earth conductor	<10 mm ²	10 mm ² CU or	additional connection terminal for a second protective earth conductor with the same cross-section as the phase conductor	10...16 mm ²	Protective earth conductor with cross-section as phase conductor	16...35 mm ²	Protective earth conductor with a cross-section of 16 mm ²	>35 mm ²	Protective earth conductor with a cross-section of 50% of the phase conductor.
Cross-section of the phase conductors	Minimum cross-section of the protective earth conductor											
<10 mm ²	10 mm ² CU or											
	additional connection terminal for a second protective earth conductor with the same cross-section as the phase conductor											
10...16 mm ²	Protective earth conductor with cross-section as phase conductor											
16...35 mm ²	Protective earth conductor with a cross-section of 16 mm ²											
>35 mm ²	Protective earth conductor with a cross-section of 50% of the phase conductor.											
 Insulation Measurement	<p>When doing an insulation measurement in accordance with VDE 0100 / Part 620, the power semiconductor of the unit and existing radio interference filters must be disconnected because of the danger of destruction. This is permissible in compliance with the standard, since all inverters are given a high voltage test in the end control at KEB in accordance with EN 50178.</p>											
 Different Earth Potentials	<p>When using components without isolated inputs / outputs, it is necessary that equipotential bonding exists between the components to be connected (e.g. through the equalizer). Disregard can cause destruction of the components by the equalizing currents.</p>											

Safety Instructions

 <p>Prevent Disturbances</p>	<p>A trouble-free and safe operation of the COMBIVERT R6 is only guaranteed when the connection instructions below are strictly followed. Incorrect operation or damage may result from incorrect installation.</p> <ul style="list-style-type: none"> • Pay attention to mains voltage. • Install power cables and control cables separately (>15 cm separation). • Use shielded / twisted control lines. Lay shield at one side to COMBIVERT R6-S to PE! • Only use suitable circuit elements to control the logic and analog inputs, whose contacts are rated for extra-low voltages. • Housing of the COMBIVERT R6 must be well earthed. Screens of larger power cable must be directly and securely attached to both the inverter PE terminal and the motor ground terminal. Remove paint finish where necessary. • Ground the cabinet or the system earth star point with the shortest connection to mains earth (avoid earth loops) • Use exclusively the line commutation throttle specified by KEB. • The average value of the supplied DC current may not exceed the maximum DC current. • If several frequency inverters are connected to the COMBIVERT R6-S the max. permissible DC link capacities of all connected frequency inverters must be considered during supply operation (see technical data).
 <p>Automatic Re-start</p>	<p>The COMBIVERT R6 can be adjusted by such way that the inverter restarts automatically after an error case (e.g. broken phase line). System design must take this into account, if appropriate, and additional monitoring or protective features added where necessary.</p>
 <p>Not Short-Circuit Proof (Supply)</p>	<p>The COMBIVERT R6 is not short-circuit proof at the power supply input! If the I2t-protection is adapted with a gR fuse, a conditional protection at supply input is possible. The short-circuit protection at the DC output is secured with a gR fuse.</p>
 <p>Conditionally Short-Circuit Proof (Feedback)</p>	<p>The COMBIVERT R6 is conditionally short-circuit proof (EN61800-5-1 / VDE 0160). After resetting the internal protection devices, the function as directed is guaranteed.</p> <p>Exception:</p> <ul style="list-style-type: none"> • If an earth-leakage fault or short-circuit often occurs at the output, this can lead to a defect in the unit.
 <p>Cyclic Activation And Deactivation</p>	<p>With applications requiring the COMBIVERT R6 to be switched on and off cyclically, maintain an off-time of at least 5 min. If you require shorter cycle times please contact KEB.</p>



RCD (Residual Current Operated Circuit-Breaker)

If personnel protection of the system is required, the COMBIVERT R6-S must be protected according to EN61800-5-1:

- 3-phase inverters (with B6 bridge-connected rectifier) by RCMA's with separation (used privileged) or RCD's type B (all-current sensitive FI's)

The tripping current should be 300mA or more, in order to avoid a premature triggering by discharge currents (about 200mA. Dependent on the load, the length of the motor cable and the use of a radio interference filter, substantially higher leakage current can occur. The connection instructions from the manufacturer and the valid local requirements must be observed.

Dependent on the available mains form (TN, IT, TT) further protective measures are necessary in accordance with VDE Part 410 4(Part4; Chapter 41).

For example, with TN-mains this protection is made with overcurrent protective devices, with IT-mains it is insulation monitoring with a pulse-code measuring method. A protective separation can be used with all mains forms as long as the required power and cable lengths permit this.

The person setting up the unit must present proof of compatibility before installing the inverter!

Circuit diagram of low voltage distribution (principle of the protective elements)

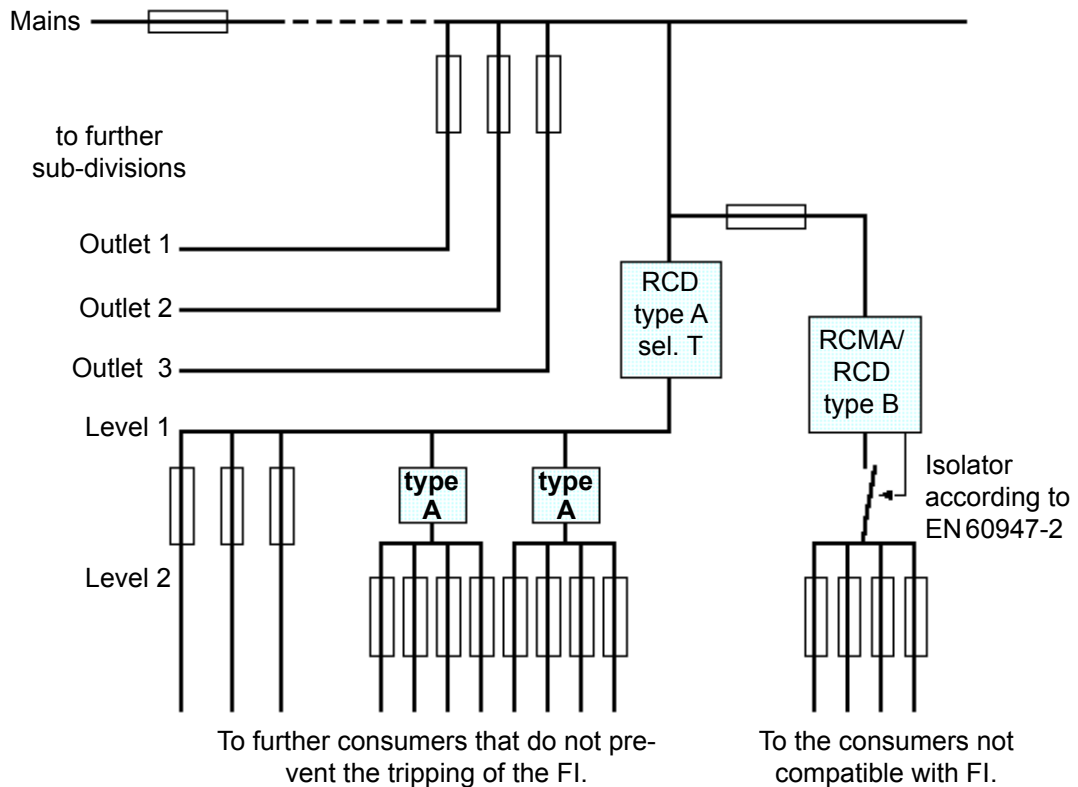

2.4 EMC instructions

COMBIVERT R6-S represent electrical equipment designed for use in industrial and commercial units. In accordance with the EMC directive 2006/108/EC, it is not obligatory to mark these devices as they represent components to be further processed by the respective machine and unit manufacturer and are not operable independently according to the EMC directive. The person installing / operating the machine / unit is obliged to prove the protective measures demanded by the EMC directive are complied with. The prescribed ratings can usually be complied with when using the radio interference voltage filters specified by KEB, and when observing the following measures and installation guidelines.

2.5 EMC conform installation

The COMBIVERT R6 is designed to be used in the second environment as defined in EN 61800-3 (unit with its own supply transformer). Take additional measures when using it in the first environment (residential and commercial area connected to public low-voltage mains)!

- Install the control cabinet or system in an appropriate and correctly way (see chapter „control cabinet installation“)
- To avoid coupled-in noise, separate supply lines, motor lines, control and data lines (low-voltage level < 48V) and leave a space of at least 15 cm between them when installing.
- In order to maintain low-resistance high frequency connections, earthing and shielding, as well as other metallic connections (e.g. mounting plate, installed units) must be in metal-to-metal contact with the mounting plate, over as large an area as possible. Make ground connections with a surface as large as possible (earthing strips).
- Only use shielded cable with copper or tin-plated braid, since steel braid is not suitable for high frequency ranges. The screen must always be installed on the compensating rail and fastened with clips or guided through the wall of the housing. Do not elongate the screen end (pigtailes) with individual conductors!
- If external interference suppression filters are used, then these must be installed as close as possible (<30cm from) the interference source and in metal-to-metal contact with the mounting plate, over as large an area as possible.
- Always equip inductive control elements (contactors, relays etc.) with suppressors such as varistors, RC-elements or damping diodes.
- All connections must be kept as short as possible and as close as possible to the earth, as free floating lines work as active and passive aerials.
- Keep connection cables straight (do not bundle). Install a non-assigned wire at one sides to the protective earth conductor.
- The flow and return circuit must be twisted when the lines are not shielded, in order to dampen common-mode noise.
- The cable for phase synchronisation between mains choke and COMBIVERT R6-S may not exceed a line length of 1 m.
- Further informations are found in the internet, see „www.keb.de“.

3. Technical Data

3.1 Power data

Unit size		29
Housing size		P
Phases		3
Rated voltage	[V]	400
Mains voltage	[V]	305...528 ±0%
Mains frequency	[Hz]	50 / 60 ±2
DC voltage range	[V _{DC}]	420...747 ±0%
Regenerative operation		
Output rated power	[kVA]	346
Rated active power	[kW]	330
Max. power output	[kVA]	433
Max. active power	[kW]	413
Regenerative rated current	[A]	500
Regenerative DC current	[A _{DC}]	590
Over load current (E.OL) 60 s	1) [A]	625
Max. regenerative DC current 60 s	[A _{DC}]	738
Power supply operation		
Input rated power	[kVA]	336
Rated active power	[kW]	310
Max. input power	[kVA]	420
Max. active power	[kW]	388
Rated supply current	2) [A]	485
DC supply current	[A _{DC}]	590
Over load current (E.OL) 60 s	[A]	606
Max. DC supply current 60 s	[A _{DC}]	738
Overload disconnection (E.OL)	[%]	160
Overvoltage switch-off (E.OP)	[V _{DC}]	800
Max. permissible DC link capacity	3) [mF]	60
Max. permissible total circuit component current (I _{TOP})	[A _{AC}]	≤6
Max. permissible mains fuse type gR	[A]	670
I ² t Integral of the limiting load of the semiconductor	[A ² s]	40500
Perm. gR fuse Siemens Sitor (no delta power system)		3NE1447-2
Max. permissible DC fuse Siemens Sitor type aR		2 x 2 x 3NE3434 (1000 V/ 500A)
Short-circuit factor at the connection point (S _{mains} /S _N)		<350
Power loss at nominal operating	[W]	2800
Max. heat sink temperature	[°C]	79

- 1) The overcurrent is specified for 1 minute. The overload cycle is 300 seconds. This corresponds to duty class 2 EN 60146-01-1.
- 2) The current data are based on a fundamental frequency component of g=0,95. The fundamental frequency component or the effective value of the input current is dependent on load and line supply conditions. At uncontrolled B6 converters the phase angle cosφ1 can be set to one, so the value of the fundamental frequency components is equal to the value of the power factor.
- 3) Please contact KEB for higher values.



Voltage stabilization must be activated at the inverter if a harmonic filter is used.



The units are not short circuit proof without corresponding dimensioned fuses



Exceeding of the max. rechargeable DC link capacity can lead to a defect.



A load removal in the DC link circle may be done only after the message „ready“.



Site altitude maximal 2000m. With site altitudes over 1000 m a derating of 1 % per 100 m must be taken into consideration.

Technical Data

3.2 Operating conditions

		Standard	Standard/ class	Instructions
Definition according to		EN 61800-2		Inverter-product standard: rated specifications
		EN 61800-5-1		Inverter-product standard: general safety
Site altitude				max. 2000m above sea level With site altitudes over 1000 m a derating of 1 % per 100m must be taken into consideration.
Ambient conditions during operation				
Climate	Temperature	EN 60721-3-3	3K3	extended to -10...45°C (with temperature over 45°C to max. 55°C a deration of 5 % per 1 K must be taken into consideration)
	Humidity		3K3	
Mechanical	Vibration	Track	EN 50155	max. amplitude of a vibration 1 mm (5...13 Hz) max. acceleration amplitude 7 m/s ² (13...200 Hz) sine
		Germ. Lloyd	Part 7-3	
		EN 60721-3-3	3M1	
Contamination	Gas		3C2	
	Solids		3S2	
Ambient conditions during transport				
Climate	Temperature	EN 60721-3-2	2K3	(without condensation)
	Humidity		2K3	
Mechanical	Vibration	Track	EN 50155	max. amplitude of a vibration 3,5 mm (2...9 Hz) max. acceleration amplitude 15 m/s ² (9...200 Hz) sine
		Germ. Lloyd	Part 7-3	
		EN 60721-3-2	2M1	
	Surge	EN 60721-3-2	2M1	max. 100 m/s ² ; 11 ms
Contamination	Gas		2C2	
	Solids		2S2	
Ambient conditions for the storage				
Climate	Temperature	EN 60721-3-1	1K4	(without condensation)
	Humidity		1K3	
Mechanical	Vibration	Track	EN 50155	max. amplitude of a vibration 1 mm (5...13 Hz) max. acceleration amplitude 7 m/s ² (13...200 Hz) sine
		Germ. Lloyd	Part 7-3	
		EN 60721-3-1	1M1	
	Surge	EN 60721-3-1	1M1	max. 100 m/s ² ; 11 ms
Contamination	Gas		1C2	
	Solids		1S2	
Type of protection		EN 60529	IP20	
Environment		IEC 664-1		Pollution degree 2
Definition according to		EN 61800-3		Inverter-product standard: EMC
EMC emitted interference (see instruction manual)				
Cable-based interferences	EN 55011		C3	→Limit A (B optional)
Radiated interferences	EN 55011		C3	→Limit A
EMC interference immunity				
ESD	EN 61000-4-2		8 kV	AD (air discharge) and CD (contact discharge)
Burst - control lines + bus	EN 61000-4-4		2 kV	
Burst - mains supply	EN 61000-4-4		4 kV	
Surge - mains supply	EN 61000-4-5		1 / 2 kV	Phase-phase / phase-ground
EMF	EN 61000-4-3		10 V/m	
Voltage variation / voltage drop	EN 61000-2-1			+10%, -15%; 90%
Voltage unsymmetries / Frequency changes	EN 61000-2-4			3%; 2%

3.3 Accessories

Unit size	29
Rated voltage	400 V
Commutation throttle	29Z1B04-1000
max. short-term overload (regenerative)	125 %
max. short-term overload (motoring)	125 %
Synchronization unit	00R5940-2409
	Control cabinet installation; max. distance to the commutation choke / harmonic filter 1 m
Patch cable	00F50C3-4010
	Length 1 m
	for connection of the synchronization unit with R6 regenerative unit

3.4 Options

Unit size	29
Mains filter	30E4T60-1001 in accordance with EN61800-3 class C3 Limit class C1 on consultation with KEB
DC-fuses	see power data
Harmonic filter	29Z1C04-1000 The overload current reduces at certain mains conditions! Please contact KEB for data to the THD value at generatoric operation
Operators	Digital operator, Interface operator
Bus operators	CAN, ProfiBus, InterBus, Ethercat, Ehternet, Sercos, ModBus, Devicenet, HSP5

3.4.1 Ferrite rings

Ferrite rings are used for the reduction of the cable-based and radiated interferences. For a high damping, the ferrite rings are attached as close as possible to the interference source, i.e. at the DC and at the motor output terminals of the frequency inverter. The conductors must be passed through the ferrite core for the use as current-compensated choke. PE must be passed outside. Further information can be taken from the provided documentation. Which ferrite ring shall be used is dependent on the used cable cross-section.

Part number	Nominal size in mm	Inside diameter in mm
0090396-2621	R 42/26/18	24,9
0090390-5241	R 56/32/18	29,5
0090395-3820	R 63/38/25	36,0
0090395-5222	R 87/54/30	54,5
0090395-5520	R 102/66/15	64,5

Technical Data - Dimensions and Weights

3.5 Dimensions and weights

3.5.1 Dimensions air-cooled inverter mounting version

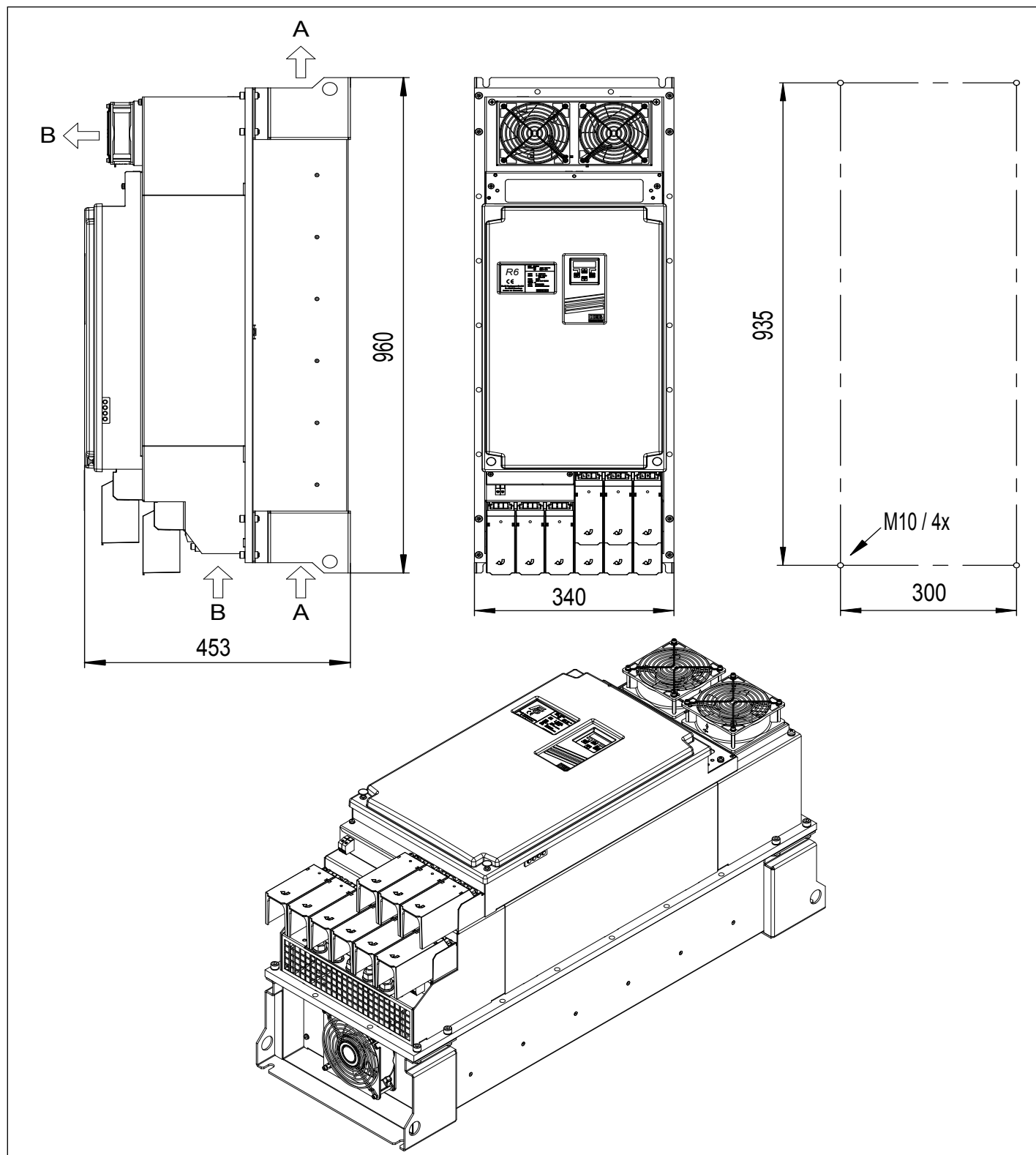

Air-cooled heat sink	Weight per module
A - heat sink air flow; B - interior ventilation	97.5 kg

3.5.2 Commutation-/mains choke

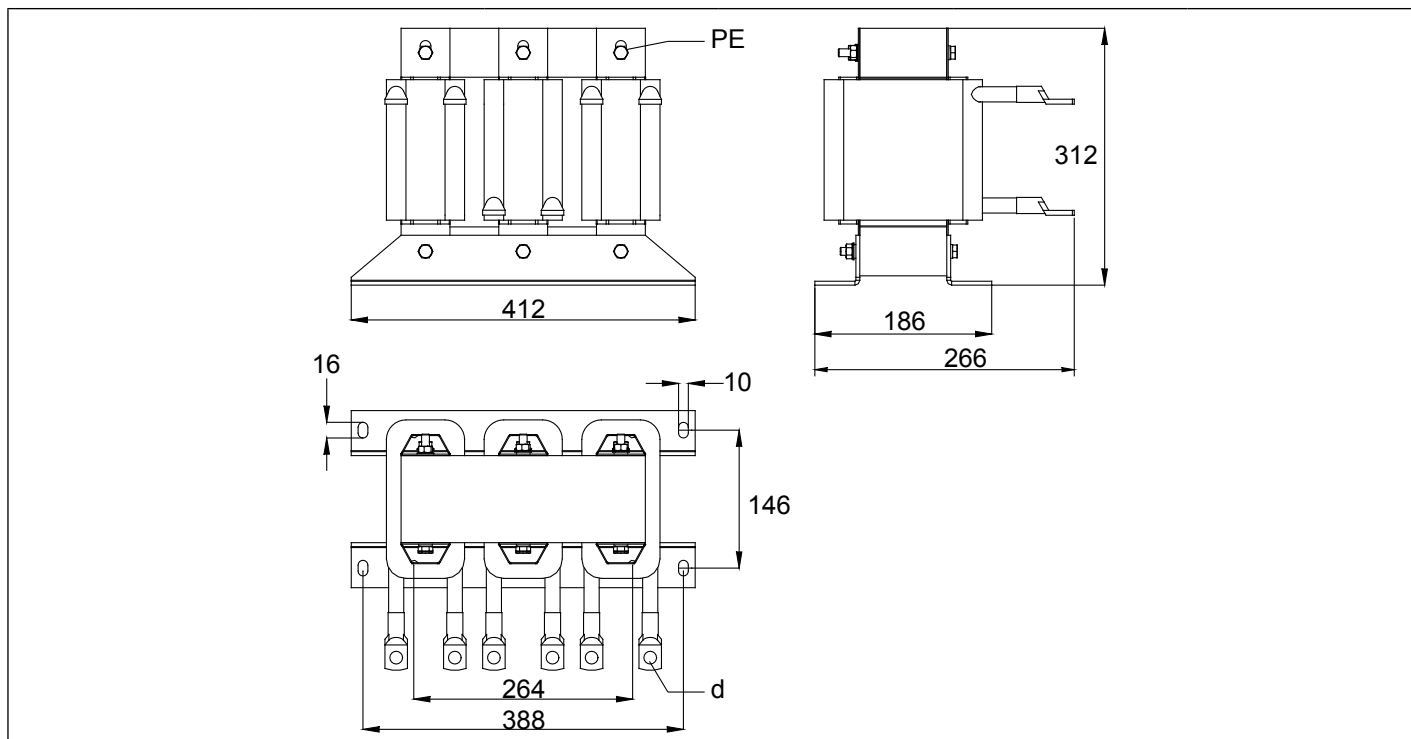

Mat.-number	Inductance	I rated	PV	Frequency	Weight
	mH	[A]	[W]	[Hz]	[kg]
29Z1B04-1000	0,061	485	530	45...65	45
Technical data of the connection terminals				Max. tightening torque	
PE	M8	Stay bolt for ring thimble		25 Nm	200 lb inch
D	Ø12	Drilling for M12 screw for maximum 2 ring thimbles with 240 mm ² for each			

Technical Data - Dimensions and Weights

3.5.3 HF side-mounted filter

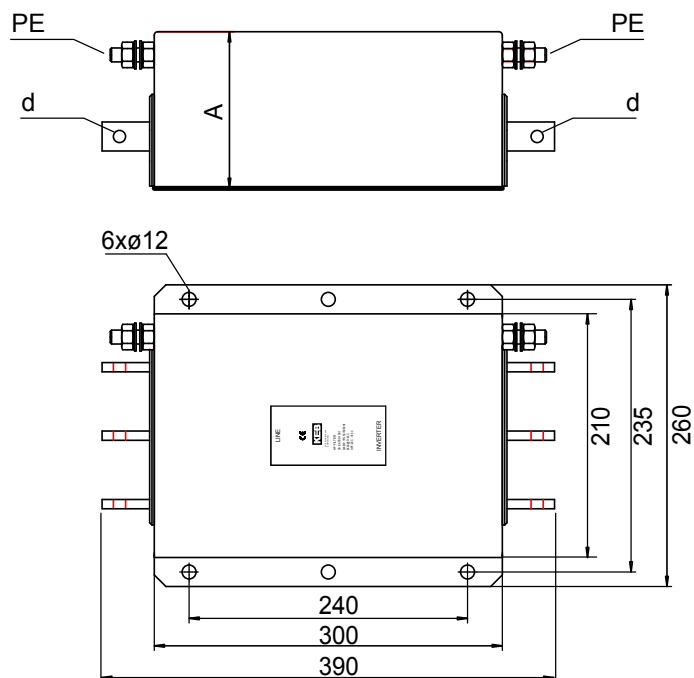

Mat.-number	U_{rated}	I_{rated}	P_v	Interference sup- pression level/	Height A	Weight
	[V]	[A]	[W]	Line length	[mm]	[kg]
30E4T60-1001	3x400/480	650	60	C3 / 30 m	135	14
Technical data of the connection terminals					Max. tightening torque	
PE	M12	Stay bolt for ring thimble			48 Nm	400 lb inch
D	Ø12	Drilling for M12 screw for maximum two ring thimbles with 240 mm ² for each				

3.5.4 Synchronization unit

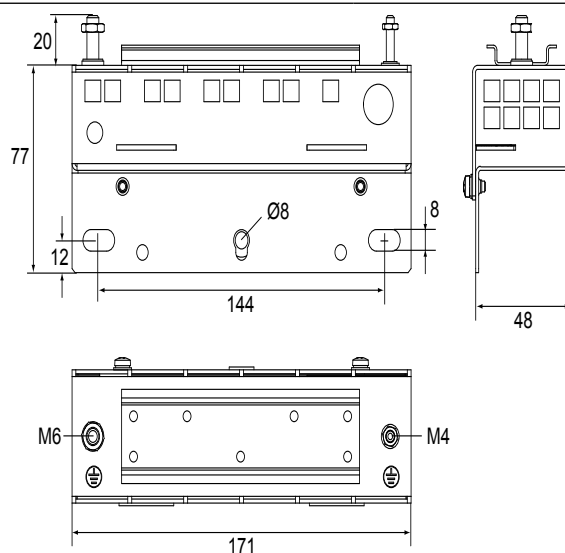

Mat.-number	00R5940-2409	Weight	0,65 kg	Max. tightening torque		
Technical data of the connection terminals					Max. tightening torque	
PE	M4	Stay bolt for ring thimble			1,3Nm	12 lb inch
PE	M6				4,5Nm	40 lb inch

4. Installation

4.1 EMC-compatible control cabinet installation

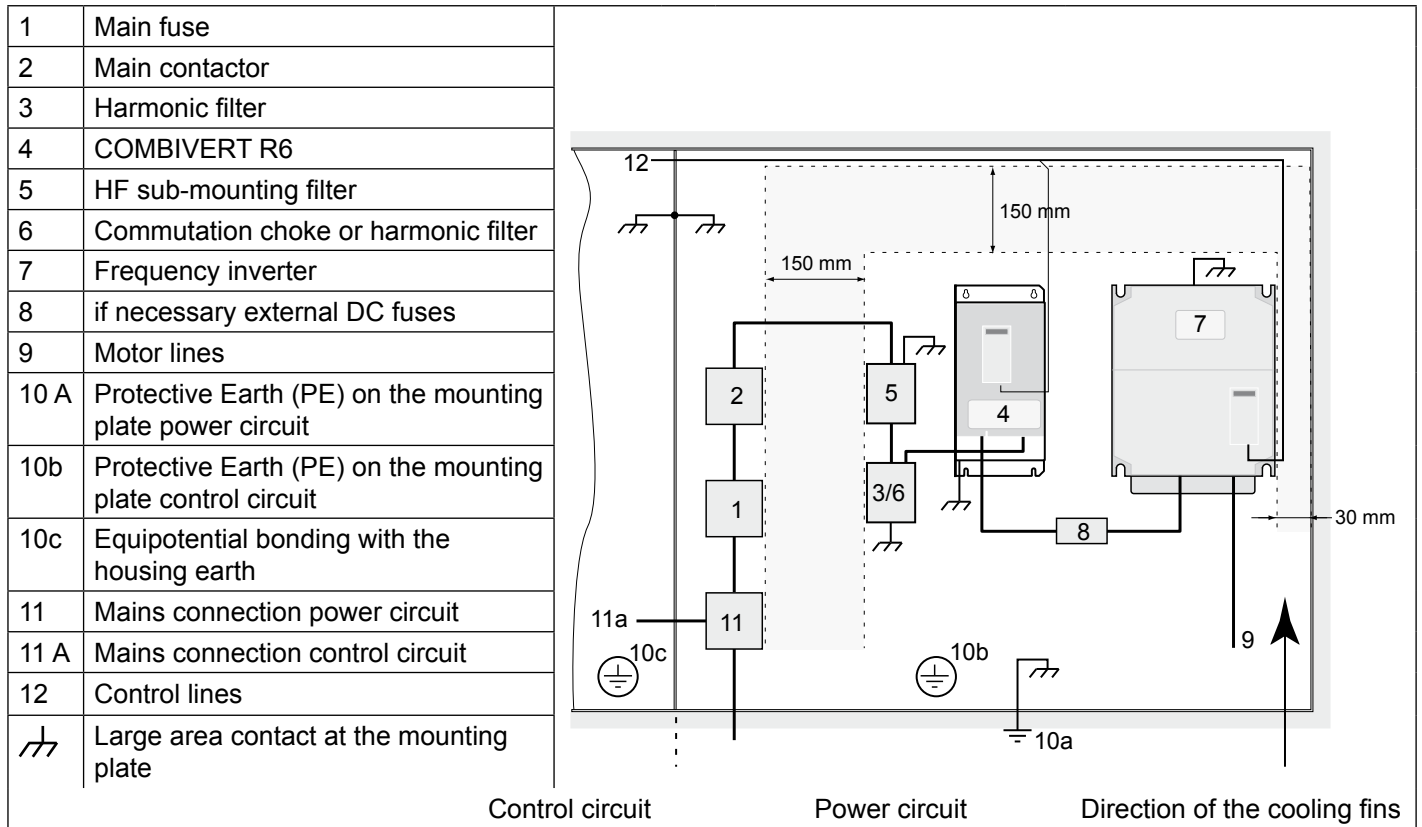

4.2 Installation Instructions



- Stationarily install and earth COMBIVERT.
- The device must not be permeated by mist or water.
- Allow for sufficient heat dissipation if installed in a dust-proof housing.
- Install the COMBIVERT in an appropriate housing in accordance with the local regulations when operating it in explosion-endangered spaces.
- Protect COMBIVERT against conductive and aggressive gases and liquids.
- The lines of the R6-S commutation throttle must be limiting to 50 cm.
- The frequency inverters must be placed in the immediate environment of the R6-S.

Connection Terminals

4.3 Connection of the COMBIVERT R6

4.3.1 Connection terminals of the power circuit

i All terminal strips meet the requirements on EN 60947-7-1 (IEC 60947-7-1)

Connection terminals of the power circuit



All terminals must be provided with cover caps against electric shock.

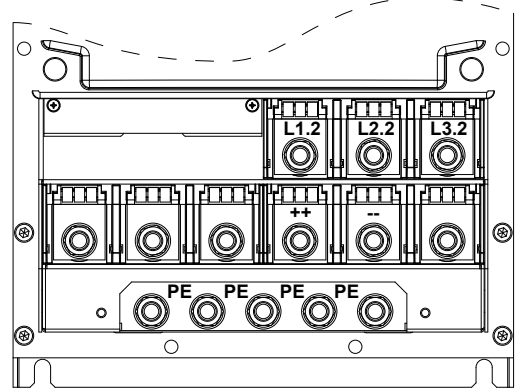

Name	Function		
L1.2, L2.2, L3.2	3-phase mains connection to the commutation throttle		
++, --	DC voltage input/output with inrush current limiting; Connection for inverter		
⊕	Connection for shielding /earthing		
Technical data of the connection terminals		max. tightening torque	
M12	Stay bolt for maximum 2 ring thimbles with 240mm ² for each	48Nm	400lb inch

4.3.2 External fan power supply

Material number	00F504W-10xx	
Connection Terminals	+, -	
Voltage supply	+24 Vdc ±10 %	
Power input	approx. 2,5A per module	
Spare fuses	3.15A Type gG minimum 50V	
permissible connection cross-section	0,2...4 mm ²	
	24 ...10AWG	
Maximum tightening torque	0,6Nm	
	5,3lb inch	

4.3.3 Connections of the control board

Connection terminals of the control board

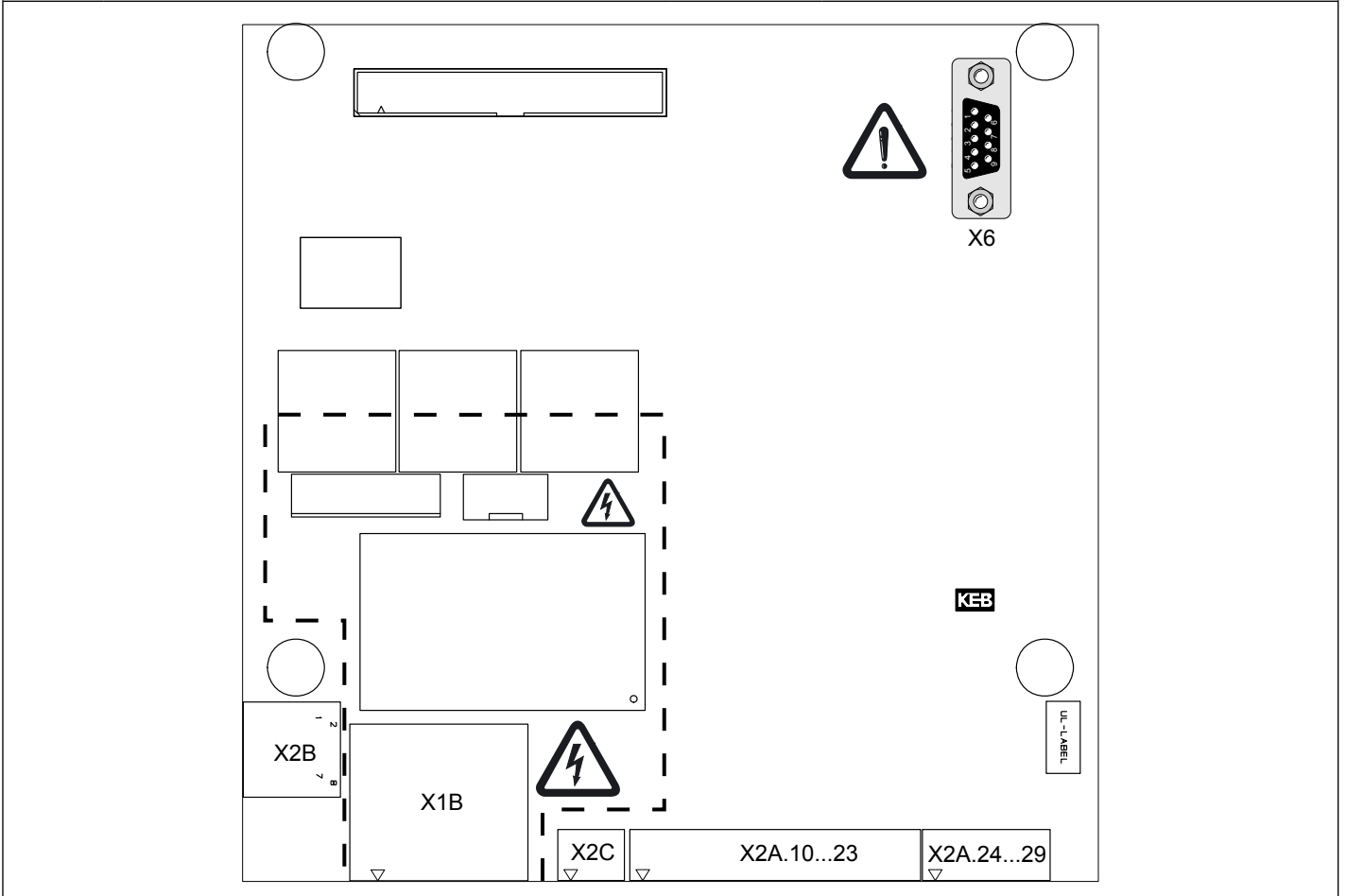

X1B	Connection precharging		Supply voltage potential !
X2B	Connection for synchronization line		
X2C	Activation of the line contactor self-holding		
X6	HSP5 operator interface		No direct PC connection
X2A	Control terminal strip	Install control and mains cable separately!	

4.3.4 Connection of the synchronization unit

X2B RJ45-socket for phase synchronization and temperature sensor	No.	Name	Function
	1	t1	Connection for temperature sensor
	2	t2	
	3	U13_syn	Synchronization phase 1 / 3
	4	–	reserved
	5	U21_syn	Synchronization phase 2 / 1
	6	–	reserved
	7	U32_syn	Synchronization phase 3 / 2
	8	–	reserved

Connection Power Unit

4.4 Connection Power Unit R6

4.4.1 Supply and regenerative operation at inverter current \leq current of one COMBIVERT R6-S

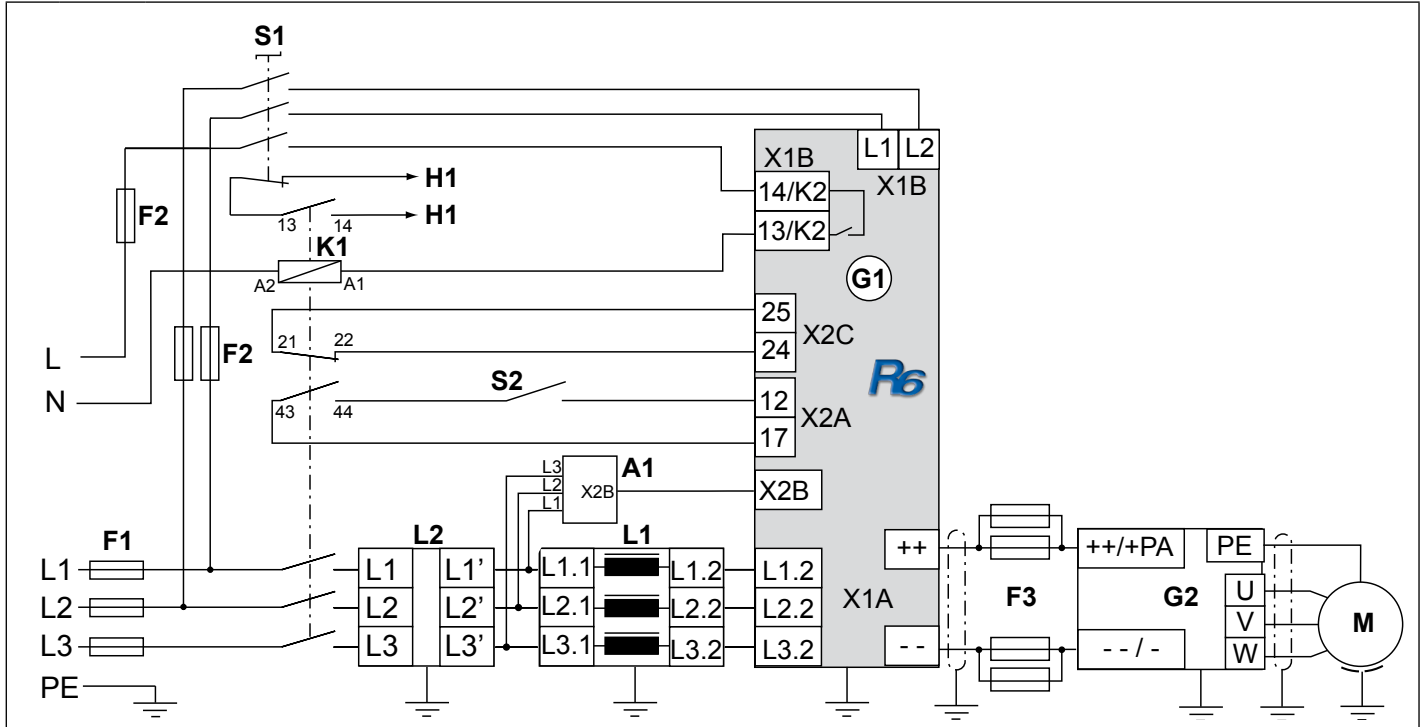

A1	Synchronization unit (max. length of the phase lines 1 m)	
F1	Mains fuse type gR	
F2	10A fuse gG/gL or automat characteristic K	
F3	DC fuses type aR/gR	The cable cross section as well as the DC fuses (see chapter 2.1) must be dimensioned to the DC rated current of the load (see technical data of the inverter).
G1	Regenerative unit COMBIVERT R6-S	
	X1A	Power circuit terminals
	X1B	Connection for precharging and switching on of line contactor K1
	X2A	Control terminal strip (X2A.12: control release; X2A.17: voltage output)
	X2B	Connection for synchronization line
X2C	Activation of the self-holding of the load shunt relay (K2 internal)	
G2	Frequency inverter with DC voltage input	
H1	Error message contactor K1 not dropped	
K1	Line contactor with auxiliary contacts	
L1	Commutation choke / harmonic filter	
L2	HF filter	
M	Motor	
S1	Switch (400 V/16AAC3)	
S2	control release; in series with line contactor K1	

4.4.2 Supply and regenerative operation at inverter currents \leq current of one COMBIVERT R6-S

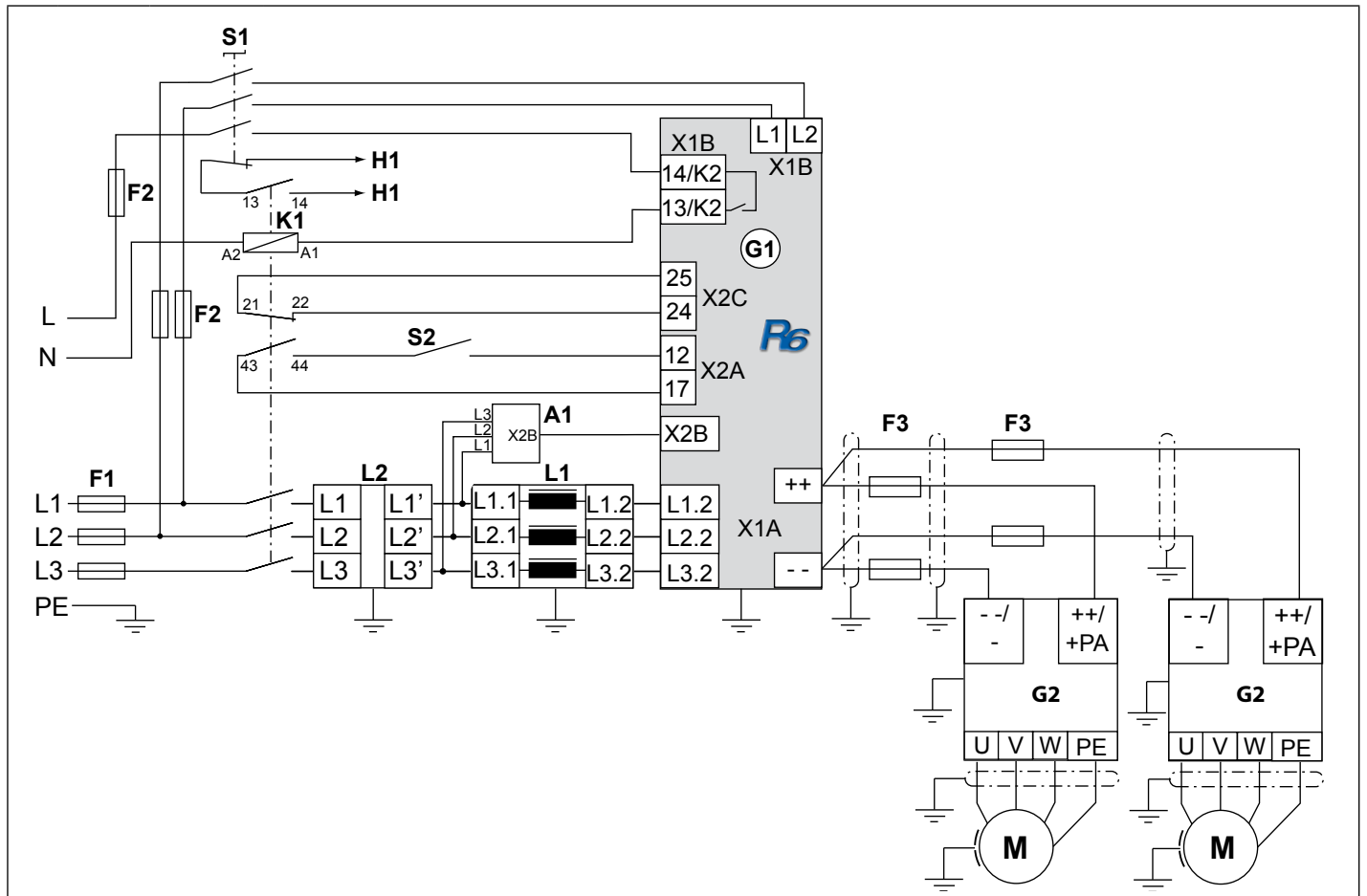

A1	Synchronization unit (max. length of the phase lines 1 m)
F1	Mains fuse type gR
F2	10A fuse gG/gL or automat characteristic K
F3	DC fuses type aR/gR The cable cross section as well as the DC fuses (see chapter 2.1) must be dimensioned to the DC rated current of the load (see technical data of the inverter).
G1	Regenerative unit COMBIVERT R6-S
X1A	Power circuit terminals
X1B	Connection for precharging and switching on of line contactor K1
X2A	Control terminal strip (X2A.12: control release; X2A.17: voltage output)
X2B	Connection for synchronization line
X2C	Activation of the self-holding of the load shunt relay (K2 internal)
G2	Frequency inverter with DC voltage input
H1	Error message contactor K1 not dropped
K1	Line contactor with auxiliary contacts
L1	Commutation choke / harmonic filter
L2	HF filter
M	Motor
S1	Switch (400V/16AAC3)
S2	control release; in series with line contactor K1

Connection Power Unit

4.4.3 Supply and regenerative operation at parallel operation of two R6-S

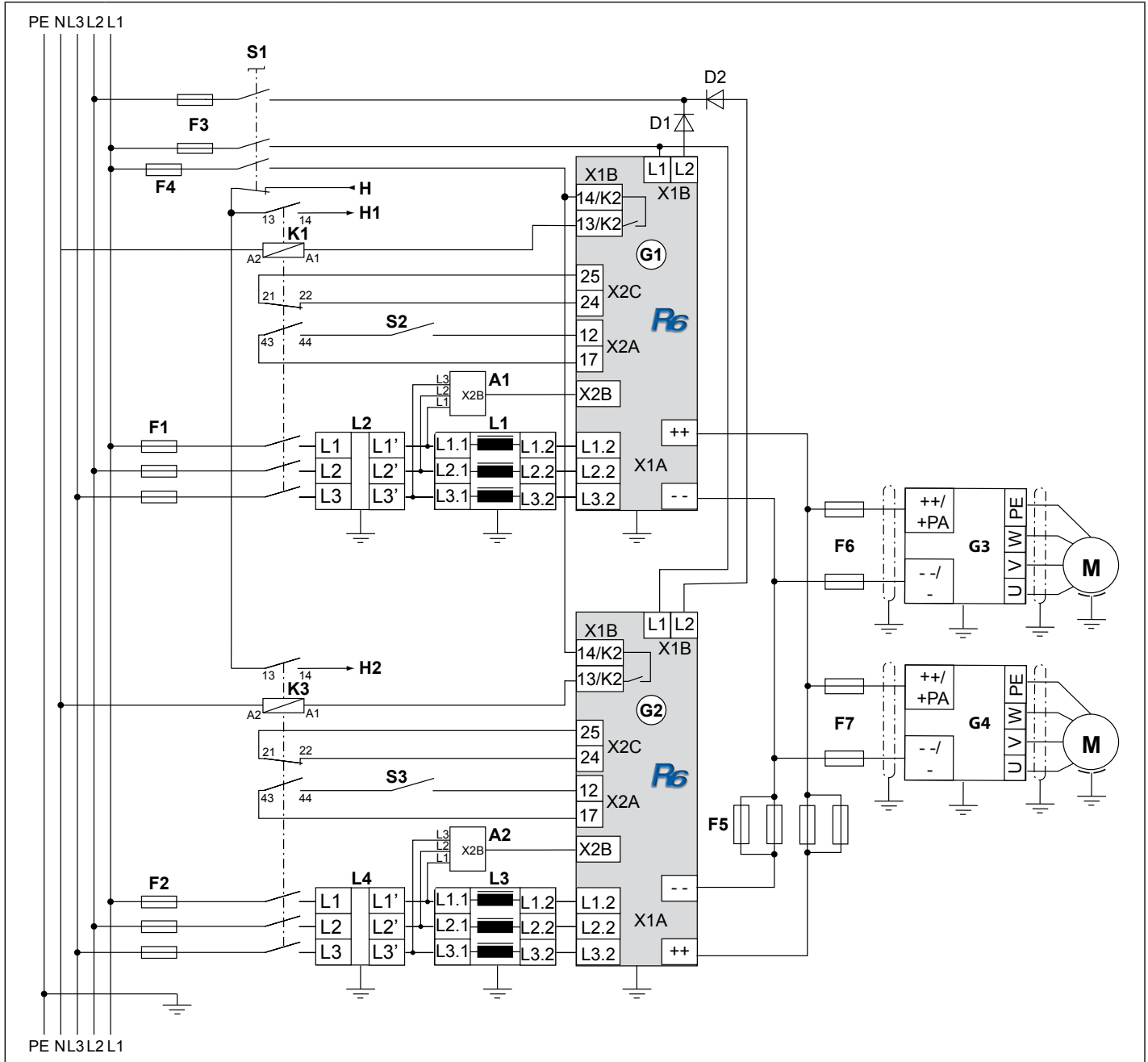

	When connecting the units absolutely pay attention to correct phasing!
	A load draw from the DC circuit may be done only if relay 1 is active (ready signal). This can be guaranteed by a series connection of the relay of the R6 units with the control release of the connected inverters (see next side).
A1, A2	Synchronization units (maximum length of the phase lines 1 m)
D1, D2	Diode 1600 V/80 A (mat.no. 0090147-3500) only required at 29R6S1P-9100
F1, F2	Mains fuse type gR
F3	Precharging fuse gG/gL or automatic circuit breaker with characteristic K dimensioned for the sum of the precharging currents (here 20 A)
F4	10A fuse gG/gL or automat characteristic K

further on next side

F5	DC fuses type aR (see technical data)	
F6, F7	DC fuses type aR/gR	The cable cross section as well as the DC fuses (see chapter 2.1) must be dimensioned to the DC rated current of the load (see technical data of the inverter).
G1, G2	Regenerative unit COMBIVERT R6-S	
	X1A	Power circuit terminals
	X1B	Connection for precharging and switching-on of line contactor K1, K3
	X2A	Control terminal strip (X2A.12: control release; X2A.17: voltage output)
	X2B	Connection for synchronization line
X2C	Activation of the self-holding of the load shunt relay (K2 internal)	
G3, G4	Frequency inverter with DC voltage input	
H	Supply of the signalling device	
H1	Error message contactor K1 not dropped	
H2	Error message contactor K2 not dropped	
K1, K3	Line contactor with auxiliary contacts	
L1, L3¹⁾	Commutation choke / harmonic filter	
L2, L4	HF filter	
M	Motor	
S1	Switch (400 V/32 A AC3) dimensioned for the sum of the precharging currents	
S2, S3	control release; in series with line contactor K1	
1)	<i>In case of parallel connection of R6-S the total power can be smaller up to 15% caused by production tolerances of the commutation choke. The impedance voltages u_k of the commutation chokes must be the same in case of parallel connection of R6-S with different sizes.</i>	

Wiring of the control release of the connected inverters

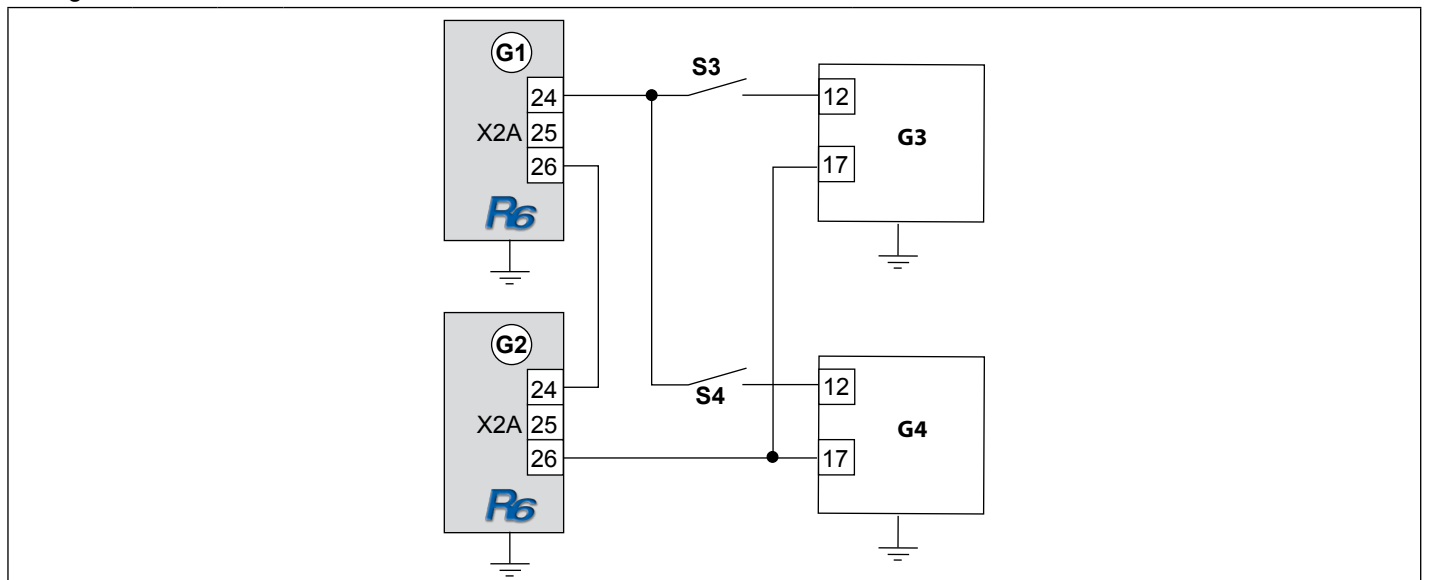

A load draw in the DC circuit may be done only when the message „ready“ is set. This can be guaranteed by a series connection of the relay R1 of the R6-S units with the control release of the connected inverters.

G1, G2	Regenerative unit COMBIVERT R6-S	
	X2A	Control terminal strip
	24	Relay 1 / NO contact
	25	Relay 1 / NC contact
	26	Relay 1 / switching contact
		Ready for operation relay

further on next side

Connection Power Unit

G3, G4	Frequency inverter COMBIVERT F5		
	X2A	Control terminal strip	
	12	Control release	This terminal assignment refers only to one COMBIVERT F5
	17	24 V-output	
S3, S4	Control release for COMBIVERT F5		

4.5 Connection of the control board version S

4.5.1 Assignment of the control terminal strip X2A

X2A

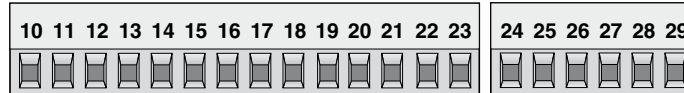

Core cross-section 0,14...1,5 mm², tightening torque 0,5 Nm

PIN	Function	Name	Description	Specifications
10	24...30 VDC input	Uin	External supply of the control board	±1 V
11	Mass	COM	Reference potential	
12	Digital input 1	ST	Control release / reset	Ri: 4,4 kΩ
13	Digital input 2	I1	programmable	
14	Digital input 3	I2	programmable	
15	Digital input 4	I3	programmable	
16	Digital in-/output	I/O (I4)	Active signal (connection of all R6 at parallel operation in master-slave procedure)	
17	24 V-output	Uout	Voltage supply for in- and outputs	approx. 24 V / max. 100 mA
18	Mass	COM	Reference potential	
19	Digital output 1	O1	Transistor output (DC > CP.19)	I _{max} : 25 mA
20	Digital output 2	O2	Transistor output (error message)	I _{max} : 25 mA
21	Analog output	ANOUT	Difference to mains frequency (CP.18)	0...±10 V / max. 5 mA
22	24 V-output	Uout	see terminal 17	
23	Mass	COM	Reference potential	
24	Relay 1 / NO contact	RLA	Relay output Ready signal (no error)	max. 30 VDC *) 0,01...2 ADC
25	Relay 1 / NC contact	RLB		
26	Relay 1 / switching contact	RLC		
27	Relay 2 / NO contact	FLA	Relay output (DC > CP.19 and tightened load-shunt)	max. 30 VDC *) 0,01...2 ADC
28	Relay 2 / NC contact	FLB		
29	Relay 2 / switching contact	FLC		

*) The relay outputs must be operated with max. 48 VDC protective separation voltage to guarantee the CE standard. After consultation KEB a current of max. 1 ADC is permissible for 120 VAC.

4.5.2 Assignment of socket X2B

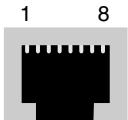
RJ45 socket for phase synchronization and temperature sensor	No.	Name	Function
	1	t1	Connection for temperature sensor
	2	t2	
	3	U13_syn	Synchronization phase 1 / 3
	4	–	reserved
	5	U21_syn	Synchronization phase 2 / 1
	6	–	reserved
	7	U32_syn	Synchronization phase 3 / 2
	8	–	reserved

The connection is made with a standard patch cable 1:1 with the socket X2B at the commutation throttle.

Connection of the Control Board

4.5.3 Wiring example

In order to prevent a malfunction caused by interference voltage supply on the control inputs, the following directions should be observed:



EMC

- Use shielded / drilled cables
- Lay shield on one side of the inverter onto earth potential
- Lay control and power cable separately (about 10...20 cm apart); Lay crossings in a right angle

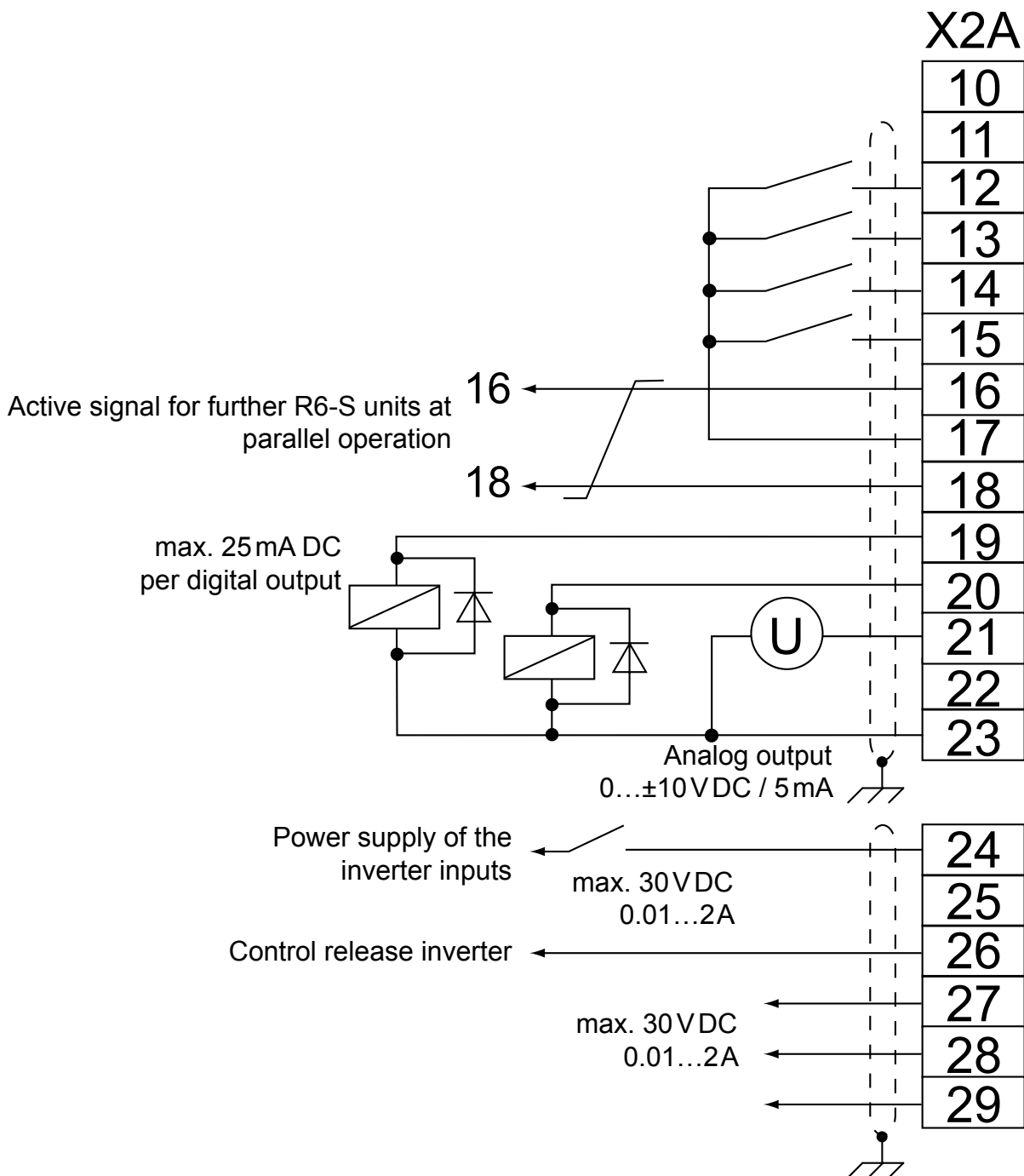

4.6 Operator

As an accessory to the local or external (option: cable 00.F5.0C0-1xxx) operation an operator is necessary. To prevent malfunctions, the COMBIVERT must be brought into nOP status before connecting / disconnecting the operator (open control release). When starting the COMBIVERT, it is started with the last stored values or factory setting.

Digital operator (part number 00.F5.060-1000)		Interface operator (part number 00.F5.060-2000)	
x	x	5-digit LED Display	
x	x	Operating-/Error display Normal "LED on" Error "LED blinks"	
-	x	Interface control Transmit "LED on"	
x	x	Double function keyboard	
-	x	X6B HSP5 programming and diagnostic interface	
-	x	X6C RS232/RS485	



Only use the operator interface for the serial data transfer to RS232/485. The direct connection, PC to the COMBIVERT is only valid with a special cable (part number 00.F5.0C0-0001), otherwise, it would lead to the destruction of the PC-interface!

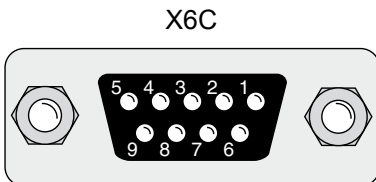

PIN	RS485	Signal	Meaning
1	-	-	reserved
2	-	TxD	Transmission signal RS232
3	-	RxD	Receive signal RS232
4	A'	RxD-A	Receive signal A RS485
5	B'	RxD-B	Receive signal B RS485
6	-	VP	Voltage supply +5V (I _{max} =50 mA)
7	C/C'	DGND	Data reference potential
8	A	TxD-A	Transmission signal A RS485
9	B	TxD-B	Transmission signal B RS485

RS 232 cable
Part number
00.58.025-001D
Length 3 m

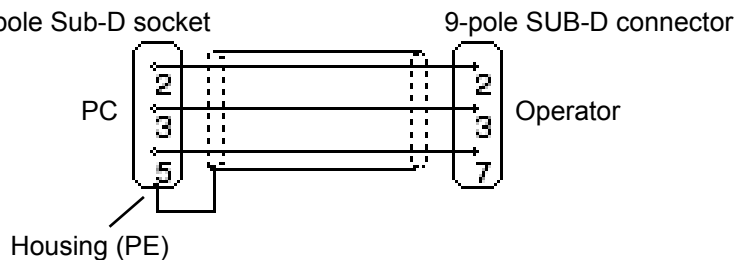

5. Operation of the Unit

5.1 Keyboard

When switching on KEB COMBIVERT R6-S the value of parameter CP.1 appears (see Drive mode to switch the keyboard function).

The function key (FUNC) changes between the parameter value and parameter number.



With UP (▲) and DOWN (▼) the value of the parameter number is increased/decreased with changeable parameters.

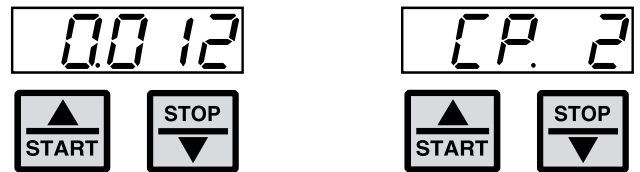

Principally during a change, parameter values are immediately accepted and stored non-volatile. However, with some parameters it is not useful that the adjusted value is accepted immediately. At this parameters (see parameter overview) the adjusted value is accepted and stored non-volatile by pressing ENTER.

If a malfunction occurs during operation, then the actual display is overwritten by the alarm message. The alarm message in the display is reset by ENTER.

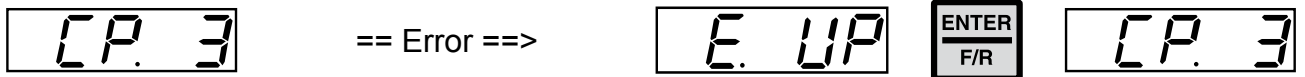

With ENTER only the error message in the display is reset. In the inverter status display (CP.3) the error is still displayed. In order to reset the error itself, the cause must be removed or a power-on reset must be made.

5.2 Operation with PC und system software COMBIVIS

Instructions for the installation and operation of the system software COMBIVIS can be taken from the appropriate software instruction.

5.3 Switch-on procedure

The COMBIVERT R6-S is initialized after connection of the power supply. The power circuit identification is checked first. If an invalid power circuit is recognized, error „E.Puci” (Power unit code invalid) is released and displayed in the operator. This error cannot be reset, the power circuit must be checked.

If a valid power circuit is recognized, COMBIVERT R6-S changes into status "SYn". The following procedures take place one after another during this synchronisation phase:

- Inspection of correct synchronisation connection (error "E.nEt" is released, if the synchronous signal is missing)
- Inspection of the phase allocation of synchronous signals to the mains phases. Error "E.SYn"

is released if a phase is missing or in case of phase allocation failure.

The actual mains frequency is determined and the correct connection of the COMBIVERT R6-S is secured after successful synchronisation. If the control release (terminal ST) is set, the COMBIVERT R6-S starts independently with the specified operation. Depending whether regenerative requirement is available, the COMBIVERT R6-S is in status „rEGEn” or „Stb”.

Status „Stb“

COMBIVERT R6-S detects a typical voltage level in the DC link circuit of the connected frequency inverter (motor operation) and keeps the modulation signals of the regenerative unit deactivated.

Status „rEGEn”

The modulation signals are activated and the unit changes into regenerative operation on exceeding the DC voltage in the DC link (CP.09) more than 103% of the input voltage. Further the regenerative unit is switched active, if regenerative operation is requested by an additional installed COMBIVERT R6-S in the system (master /slave operation).

Operation of the Unit

5.4 Parameter summary

The CP parameters are one of the parameter selection defined by KEB. You need an application manual in order to get access to the entire parameters.

Display	Parameter	Setting range	Resolution	Factory setting	Origin
CP.00	Password input	0...9999	1	–	ud.01
CP.01	Status display	–	–	–	ru.00
CP.02	Actual line frequency	–	0.1 Hz	–	ru.03
CP.03	AC current L1	–	0.1 A	–	ru.08
CP.04	AC current L2	–	0.1 A	–	ru.09
CP.05	AC current L3	–	0.1 A	–	ru.10
CP.06	Actual DC utilization	–	1%	–	ru.13
CP.07	Peak DC utilization	–	1%	–	ru.14
CP.08	DC current	–	0.1 A	–	ru.15
CP.09	DC voltage	–	1V	–	ru.19
CP.10	Peak DC voltage	–	1V	–	ru.20
CP.11	Power module temperature	–	1°C	–	ru.38
CP.12	OL counter display	–	1%	–	ru.39
CP.13	Actual power	–	0.1 kW	–	ru.81
CP.14	Total regen	–	0.1 kWh	–	ru.82
CP.15	Total motor	–	0.1 kWh	–	ru.83
CP.16	Total net	–	0.1 kWh	–	ru.84
CP.17	Actual net	–	0.1 kVA	–	ru.85
CP.18	Analog output 1 / gain	±20,00	0,01	1,00	An.33
CP.19	DC switching level	±30000,00V	0,01V	600,00V	LE.00
CP.20	General fault reset	0...10	1	3	Pn.15
CP.21	Last error	–	–	–	In.21
CP.22	Last error -1	–	–	–	In.21
CP.23	Last error -2	–	–	–	In.21
CP.24	Last error -3	–	–	–	In.21
CP.25	Last error -4	–	–	–	In.21
CP.26	Last error -5	–	–	–	In.21
CP.27	Last error -6	–	–	–	In.21
CP.28	Last error -7	–	–	–	In.21
CP.29	Software version	1.11	–	1.11	In.06
CP.30	Software date	0801.7	–	0801.7	In.07
CP.31	Power unit identification	250	–	–	SY.03
CP.32	Puls off level	0.0...-1000.0 kW	0.1 kW	-0.8 kW	cS.06
CP.33	Operating mode	0...3	1	0	Pn.19
CP.34	Regeneration level	100...120%	1%	103%	cS.02

5.5 Password input

No.	Name	r/w	Enter	Origin
CP.00	Password input	-	-	ud.01
<p>Ex works the COMBIVERT R6-S is supplied without password protection, i.e. all changeable parameters can be adjusted. After parameterizing the inverter can be secured against unauthorized access. The adjusted mode is stored.</p>				
Barring the CP-Parameter				
Enabling the CP-Parameter (for protection the right password must be made unrecognizable against unauthorized access)				

5.6 Monitoring- and analysis parameters

The following parameters serve for the functional monitoring during operation.

No.	Name	r/w	Enter	Origin
CP.01	Status display	-	-	ru.00
<p>The status display shows the actual working conditions of the COMBIVERT.</p>				
<p>Status Messages</p>				
rEGEn	Feedback active (regeneratoric operation)			
bbL	Count down of the base-block time, R6-S released			
noP	„no Operation“ control release not bridged, modulation switched off			
nEtoF	Mains power failure; regenerative operation is further possible, if the disconnecting time E.nEt (Pn.14) > 0 s			
Stb	R6-S regenerative unit in stand-by operation (motoric operation)			
SYn	Inspection of phase allocation and synchronization of mains angle			
<p>Error Messages</p>				
E.dOH	Error! Overtemperature choke“, temperature monitoring of the commutation choke has triggered and the coolong-off period is up.			
E. EF	External Fault, error message by an external unit			
E.nEt	Error! Mains, one or more phases are missing			
E.nOH	No Over Heat, over-temperature error not present (E.OH), error can be reset.			
E.nOL	No Over Load, cooling time after E.OL is up , error can be reset.			
E. OC	Error! Overcurrent“, output current too high or ground fault			
E. OH	Error! Overtemperature“, overheating at heat sink (see „technical data“)			
				further on next side

Operation of the Unit

No.	Name	r/w	Enter	Origin
CP.01	Status display	–	–	ru.00
E.OHI	Error! Interior temperature“, temperature in the interior > 95 °C			
E. OL	Error! Overload“, overload monitoring of the regenerative unit has responded			
E. OP	Error! Overvoltage“, DC link voltage too high			
E. Pu	„Error in power unit“, power unit code is missing, load shunt relay defective			
E.Puci	Power unit identification invalid			
E.Puch	Error! Power unit changed“, a configured unit for 400V was connected to a 230V mains (or reverse). Load factory setting with CP.31, so the unit can adapt itself to the changed supply system.			
E.SYn	Error! Synchronization“, phase allocation at commutation throttle not correct			
E. UP	Error! Undervoltage“, DC link voltage too low			

No.	Name	r/w	Enter	Origin
CP.02	Actual line frequency	–	–	ru.03
After switching on the actual mains frequency is determined during the initialization phase. Slowly changes of the mains frequency during the operation are recognized and displayed in CP.02. CP.02 displays the actual regenerative frequency, if the COMBIVERT R6-S is in "netof" status.				
Resolution		Meaning		
0,01 Hz		positive values = clockwise rotating field		
		negative values = counterclockwise rotating field		

No.	Name	r/w	Enter	Origin
CP.03	AC current L1	–	–	ru.08
CP.04	AC current L2	–	–	ru.09
CP.05	AC current L3	–	–	ru.10
Resolution		Meaning		
0.1 A		Display of the actual input current of the respective phase.		

No.	Name	r/w	Enter	Origin
CP.06	Actual DC utilization	–	–	ru.13
Resolution		Meaning		
1 %		Independent whether power supply or regenerative operation, the display indicates the actual utilization of the COMBIVERT R6-S. 100 % correspond to the rated current of the COMBIVERT R6-S.		

No.	Name	r/w	Enter	Origin
CP.07	Peak DC utilization	–	–	ru.14
Resolution		Meaning		
1 %		Parameter CP.07 enables to recognize short-term peak loads within an operating cycle. For that the highest value of CP.06 is stored in CP.07. The peak value memory can be cleared by pressing the UP and DOWN key or over bus by writing any value you like to the address of CP.07. Switching off COMBIVERT R6-S also clears the memory.		

No.	Name	r/w	Enter	Origin
CP.08	DC current	–	–	ru.15
Resolution		Meaning		
0.1 A		Display of the actual DC output current in ampere.		

No.	Name	r/w	Enter	Origin
CP.09	DC - voltage	–	–	ru.19
Resolution		Meaning		
1 V		Display of actual DC-link voltage in volt. The value is measured at the DC output terminals of the COMBIVERT R6-S.		

No.	Name	r/w	Enter	Origin
CP.10	Peak DC voltage	–	–	ru.20
Value range		Meaning		
0...1000 V		Parameter CP.10 enables to recognize voltage peaks within an operating cycle. For that the highest value of CP.09 is stored in CP.10. The peak value memory can be cleared by pressing the UP and DOWN key or over bus by writing any value you like to the address of CP.10. Switching off COMBIVERT R6-S also clears the memory.		

No.	Name	r/w	Enter	Origin
CP.11	Power module temperature	–	–	ru.38
Resolution		Meaning		
1 °C		Display of the actual heat sink temperature. On exceeding the maximum heat sink temperature (see "technical data") the modulation is switched off and error E.OH is displayed. Message E.nOH is displayed after the cooling period. The error can be reset now.		

No.	Name	r/w	Enter	Origin
CP.12	OL counter display	–	–	ru.39
Resolution		Meaning		
1 %		The permanent load of the COMBIVERT R6-S can be evaluated with this parameter, in order to avoid an E.OL error (in-time load reduction). Error E.OL is released, if the overload counter reaches 100 %.		

Operation of the Unit

No.	Name	r/w	Enter	Origin
CP.13	Actual power	–	–	ru.81
	Resolution	Meaning		
	0.01 kW	CP.13 displays the current active power of the COMBIVERT R6-S. Motor power is displayed with positive values, generatoric power is displayed with negative values.		

No.	Name	r/w	Enter	Origin
CP.14	Total regen	–	–	ru.82
	Resolution	Meaning		
	1 kW	Counter for the regeneratoric electric work to the mains.		

No.	Name	r/w	Enter	Origin
CP.15	Total motor	–	–	ru.83
	Resolution	Meaning		
	1 kW	Counter for the supplied electrical work from the mains in kWh.		

No.	Name	r/w	Enter	Origin
CP.16	Total net	–	–	ru.84
	Resolution	Meaning		
	1 kW	Display of the difference between supplied and regeneratoric work. The result is displayed by right sign.		

No.	Name	r/w	Enter	Origin
CP.17	Actual net	–	–	ru.85
	Resolution	Meaning		
	0.01 kVA	Display of the current apparent power at the mains input.		

5.7 Special adjustments

The power supply- and regenerative unit can be adapted to the application with the following parameters.

No.	Name	r/w	Enter	Origin
CP.18	Analog output 1 / gain	yes	–	An.33
The analog output displays the difference between actual supply frequency and set supply frequency. At factory setting of CP.18 this corresponds to 1 V per 0.1 Hz difference. The display occurs with right sign. The reference value of 50 or 60 Hz is determined during power on.				
Setting range		Setting	Meaning	
0...±20,00		1,00	The amplification to the desired output voltage can be adapted with CP.18. Max. possible: ±10V.	

No.	Name	r/w	Enter	Origin
CP.19	DC switching level	yes	–	LE.00
This parameter determines the switching level for transistor output O1, as well as relay output 2.				
Setting range		Setting	Meaning	
0...3200.00 V		600,00 V	The switching condition is fulfilled and the transistor output is set if the DC voltage level exceeds the adjusted value in CP.19. Relay output 2 is set, if the load shunt relay is additionally tightened.	

No.	Name	r/w	Enter	Origin
CP.20	General fault reset	yes	–	Pn.15
		An automatic error reset can be activated with this parameter. Attention, the machine manufacturer must observe appropriate protective measures for operators staff and machine.		
Setting range		Setting	Meaning	
0		3	No automatic error reset.	
1...10			Maximum errors, which are reset within one hour. If the number of errors per hour exceeds the adjusted value in CP.20, only a manual reset via terminal strip can be made.	

Operation of the Unit

No.	Name	r/w	Enter	Origin
CP.21	Last error	–	–	In.24 set 0
CP.22	Last error (t-1)	–	–	In.24 set 1
CP.23	Last error (t-2)	–	–	In.24 set 2
CP.24	Last error (t-3)	–	–	In.24 set 3
CP.25	Last error (t-4)	–	–	In.24 set 4
CP.26	Last error (t-5)	–	–	In.24 set 5
CP.27	Last error (t-6)	–	–	In.24 set 6
CP.28	Last error (t-7)	–	–	In.24 set 7

Parameters CP.21... 28 display the last eight errors which occur. With exception error "undervoltage E.UP" is not stored. The oldest error is displayed in CP.28. A new error is stored in CP.21. All other errors are shifted to the next parameter. The oldest error (CP.28) is not applicable.

The meaning of the error messages is described in parameter CP.1.

No.	Name	r/w	Enter	Origin
CP.29	Software version	–	–	In.06
Value range		Meaning		
0,00...9,99		Display of the inverter software version number (e.g. 1,11).		

No.	Name	r/w	Enter	Origin
CP.30	Software date	–	–	In.07
Value range		Meaning		
0...6553.5		Display of the inverter software date in the format „ddmm.y“.		

No.	Name	r/w	Enter	Origin
CP.31	Power unit code	–	–	SY.3
The COMBIVERT R6-S detects the connected supply system (230 V/400 V) at the first switching on. Depending on the supply system the COMBIVERT R6-S adjusts internally certain parameter values.				
If the COMBIVERT R6-S connected to another supply system, these stored parameter values are not correct any longer. Error message "power unit changed (E.Puch)" is displayed.				
Value range		Meaning		
0...32767		If the displayed value is written, only the power unit dependent parameters are re-initialised. By writing of any other value error E.Puch is reset and the default values are loaded. Now the COMBIVERT R6-S reacts like a first switching on.		

No.	Name	r/w	Enter	Origin
CP.32	Puls off level	yes	–	cS.06
Value range		default	Meaning	
0.0...-1000.0 kW		-0.8 kW	If the adjusted regenerative power is decreased, the COMBIVERT R6-S switches the modulation off after turn-off delay and changes into standby mode (display: „Stb“).	

No.	Name	r/w	Enter	Origin
CP.33	Operating mode	yes	yes	Pn.19
<p>This parameter determines the master or slave of regenerative units at parallel connection. Further it is adjusted whether a harmonic filter or a commutation choke is series-connected. Single units must be adjusted to master.</p>				
Value range		Meaning		
0		Master with commutation choke		
1		Master with harmonic filter		
2		Slave with commutation choke		
3		Slave with harmonic filter		

No.	Name	r/w	Enter	Origin
CP.34	Regeneration level	yes	–	cS.02
Value range		Meaning		
100...120 %		<p>The regeneration level determines the starting value to energy regeneration. The adjusted value refers to the reference value of the DC voltage in percentage. The status changes from Standby „Stb“ to regeneration „rEGEn“.</p>		

A. Appendix

A.1 Dimensioning of power supply and regenerative units

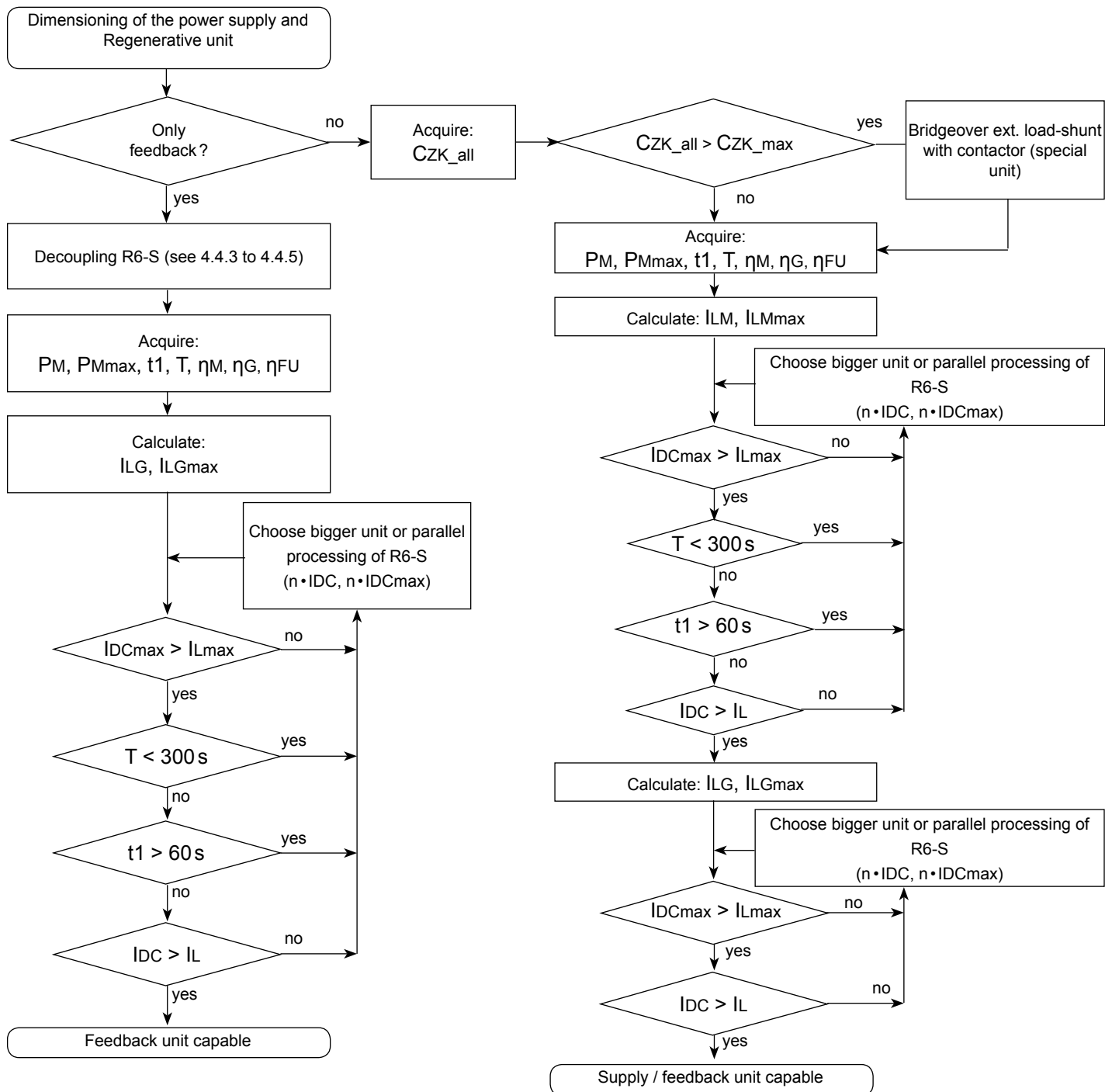

PM	Mechanical power	η_M	Motor efficiency	IDC	DC output current R6-S
PMmax	Max. mechanical power	η_G	Gearbox efficiency	IDCmax	Max. DC output current R6-S
t1	Overload time	η_{FU}	Inverter efficiency	ILG	DC load regenerative current
t	Last cycle	ILM	DC load motoric current	ILGmax	Max. DC load regenerative current
n	Number of R6-S	ILMmax	Max. DC load motoric current	CZK_all	DC link capacity of all frequency inverters
				CZK_max	Max. connecting capacity R6-S

A.2 DC link capacitors of KEB frequency inverters

200V units		400V units	
Size	Capacity	Size	Capacity
05	780 μ F	05	180 μ F
07	880 μ F (940 μ F*)	07	180 μ F (300 μ F*)
09	1080 μ F	09	300 μ F
10	1080 μ F	10	345 μ F
12	2220 μ F	12	470 μ F
13	3280 μ F	13	580 μ F
14	4100 μ F	14	650 μ F
15	4100 μ F	15	940 μ F
16	5040 μ F	16	1290 μ F
17	9900 μ F	17	1640 μ F
18	13200 μ F	18	1875 μ F
19	15600 μ F	19	2700 μ F
20	16500 μ F	20	3900 μ F
21	19800 μ F	21	4950 μ F
*) special version		22	4950 μ F
		23	6350 μ F
		24	8400 μ F
		25	9900 μ F
		26	11700 μ F
		27	14100 μ F

*) special version

A.3 Dimensioning of decoupling diodes

R6-S	Material number	Type	Volume	Ta [°C]	Th [°C]	Rha [K/W]
15	0090147-3500	1600V / 80A	2	45	90	1.50
19	0090147-4101	1600V / 120A	2	45	90	0.84
25	0090147-6009	1600V / 560A	2	45	90	0.19
29	0090147-6009	1600V / 560A	2 x 2	45	90	0.09

Legend

Ta: maximum ambient temperature

Th: maximum heat sink temperature

Rha: required thermal resistance of the heat sink at rated operation
(thermal value of the thermal compound $\geq 0.5\text{W}/(\text{m}^2\text{K})$)



Karl E. Brinkmann GmbH

Försterweg 36-38 • D-32683 Barntrup
fon: +49 5263 401-0 • fax: +49 5263 401-116
net: www.keb.de • mail: info@keb.de

KEB worldwide...

KEB Antriebstechnik Austria GmbH

Ritzstraße 8 • A-4614 Marchtrenk
fon: +43 7243 53586-0 • fax: +43 7243 53586-21
net: www.keb.at • mail: info@keb.at

KEB Antriebstechnik

Herenveld 2 • B-9500 Geraardsbergen
fon: +32 5443 7860 • fax: +32 5443 7898
mail: vb.belgien@keb.de

KEB Power Transmission Technology (Shanghai) Co.,Ltd.

No. 435 QianPu Road, Songjiang East Industrial Zone,
CHN-201611 Shanghai, P.R. China
fon: +86 21 37746688 • fax: +86 21 37746600
net: www.keb.cn • mail: info@keb.cn

KEB Antriebstechnik Austria GmbH

Organizační složka
K. Weise 1675/5 • CZ-370 04 České Budějovice
fon: +420 387 699 111 • fax: +420 387 699 119
net: www.keb.cz • mail: info.keb@seznam.cz

KEB Antriebstechnik GmbH & Co. KG

Wildbacher Str. 5 • D-08289 Schneeberg
fon: +49 3772 67-0 • fax: +49 3772 67-281
mail: info@keb-combidrive.de

KEB España

C/ Mitjer, Nave 8 - Pol. Ind. LA MASIA
E-08798 Sant Cugat Sesgarrigues (Barcelona)
fon: +34 93 897 0268 • fax: +34 93 899 2035
mail: vb.espana@keb.de

Société Française KEB

Z.I. de la Croix St. Nicolas • 14, rue Gustave Eiffel
F-94510 LA QUEUE EN BRIE
fon: +33 1 49620101 • fax: +33 1 45767495
net: www.keb.fr • mail: info@keb.fr

KEB (UK) Ltd.

6 Chieftain Business Park, Morris Close
Park Farm, Wellingborough GB-Northants, NN8 6 XF
fon: +44 1933 402220 • fax: +44 1933 400724
net: www.keb-uk.co.uk • mail: info@keb-uk.co.uk

KEB Italia S.r.l.

Via Newton, 2 • I-20019 Settimo Milanese (Milano)
fon: +39 02 33535311 • fax: +39 02 33500790
net: www.keb.it • mail: kebtalia@keb.it

KEB Japan Ltd.

15-16, 2-Chome, Takanawa Minato-ku
J-Tokyo 108-0074
fon: +81 33 445-8515 • fax: +81 33 445-8215
mail: info@keb.jp

KEB Korea Seoul

Room 1709, 415 Missy 2000
725 Su Seo Dong, Gang Nam Gu
ROK-135-757 Seoul/South Korea
fon: +82 2 6253 6771 • fax: +82 2 6253 6770
mail: vb.korea@keb.de

KEB RUS Ltd.

Krasnokazarmeny proezd 1,
Metrostation „Aviamotornay“
RUS-111050 Moscow / Russia
fon: +007 445 695 3912 • fax: +007 495 645 3913
mail: info@keb.ru

KEB Sverige

Box 265 (Bergavägen 19)
S-43093 Hälsö
fon: +46 31 961520 • fax: +46 31 961124
mail: vb.schweden@keb.de

KEB America, Inc.

5100 Valley Industrial Blvd. South
USA-Shakopee, MN 55379
fon: +1 952 224-1400 • fax: +1 952 224-1499
net: www.kebamerica.com • mail: info@kebamerica.com

More and newest addresses at <http://www.keb.de>

© KEB	
Mat.No.	00R6SEB-KP00
Rev.	1C
Date	09/2008