

COMBIVERT



BETRIEBSANLEITUNG

INSTRUCTION MANUAL

Version 1.5

Vorbemerkung

Bevor Sie mit der Installation der R4-S-Rückspeiseeinheit beginnen, lesen Sie diese Anleitung bitte sorgfältig und beachten Sie unbedingt die darin enthaltenen Hinweise und Vorschläge.

Diese Betriebsanleitung muß jedem Anwender zugänglich gemacht werden.

Vor jeglichen Arbeiten muß sich der Anwender mit dem Gerät vertraut machen. Darunter fällt insbesondere die Kenntnis und Beachtung der Sicherheits- und Warnhinweise. Lesen Sie deshalb unbedingt die „Technische Dokumentation Teil 1“.

Sicherheitsrelevante Texte sind kursiv ausgezeichnet.

Die im Kapitel „Sicherheitshinweise“ aufgeführten Hinweise sollten aus folgenden Gründen unbedingt beachtet werden:

- Sicherheit für Mensch und Maschine
- Funktion und Störanfälligkeit
- TÜV-Abnahmen und Zertifizierung
- Garantie und Gewährleistung

Die in dieser Betriebsanleitung verwendeten Piktogramme haben folgende Bedeutung:



Gefahr!
Warnung!
Vorsicht!



Achtung!
Unbedingt
beachten!



Information!
Hilfe!
Tip!

Remark

Before you start with the installation of the R4-S-regenerative unit, please read this manual carefully and pay special attention to the notes and suggestions.

This manual must be made available to every user.

Before working with the unit the user must become familiar with it. This especially applies to the knowledge and observance of the following safety and warning indications. Make sure to read "Technical Documentation Part 1".

Safety indication text is written in italic type.

The instructions in this chapter must be absolutely observed for the following reasons:

- Safety for people and machines
- Function and susceptibility to faults
- Guarantee and warranties

The pictograms used here have the following meaning:



Danger!
Warning!
Caution!



Attention!
Essential
Measure !



Information!
Comment!
Tip!

Table of Contents

1	Safety Instructions	6
2	Product Description	9
2.1	Use as instructed	9
2.2	Field Conditions	9
2.3	Device Identification	9
2.4	Technical Data	10
3	Transport and Storage	11
4	Installation	11
4.1	Installation of the Unit	12
4.1.1	Dimensions	12
4.1.2	Installation Instructions	13
4.2	Connection of the Power Circuit	14
4.2.1	Standard Connection	15
4.2.2	Parallel Operation	16
4.2.3	R4-S Regenerative unit and Supply Unit	17
4.2.4	R4-S as Combination with Inverter	18
4.2.5	Hints for EMV-Conform-Wiring	19
4.3	Connection of the Control	22
4.3.1	Terminal Assignment X1	23
5	Operation of the Unit	24
5.1	Initialisation	24
5.2	Operation during the Unit is running	24
5.2.1	Operation with Interface-Operator	25
5.2.2	Operation with PC and System Software COMBIVIS	26
5.3	Keyboard Operation	26
5.3.1	Standard Operation	26
5.3.1.1	Display of the Parameter Identification	26
5.3.1.2	Display of the Parameter Value	27
5.3.2	Special Displays	28

Table of Contents

5.4	Parameter	28
5.4.1	Parameter Summary	28
5.4.2	Parameter Description	29
5.4.2.1	Run (ru) – Parameter	29
5.4.2.2	Protection (Pn) – Parameter	31
5.4.2.3	Control (CS) – Parameter	33
5.4.2.4	User Definition (ud) – Parameter	34
5.4.2.5	Free-programmable (Fr) – Parameter	35
5.4.2.6	Analog I/O (An) – Parameter	36
5.4.2.7	Digital Input (di) – Parameter	37
5.4.2.8	Digital Output (do) – Parameter	39
5.4.2.9	Level (LE) – Parameter	41
5.4.2.10	Information (In) – Parameter	42
6	Servicing	44
7	Out of Service, Demounting and Waste Disposal	44
8	Fault Diagnosis	45
9	Register	46
10	Mark of Conformity	47
11	Short Description	49

Parameter-Annex

	Parameter Summary	26
ru	Run	27
	Parameter Description – ru. 0	27
	Parameter Description – ru. 7/8/11/12/14/15	28
	Parameter Description – ru. 16/17/24/29/52	29
Pn	Protection	30
	Parameter Description – Pn. 0/1/16/59	30
CS	Control	31
	Parameter Description – CS. 27/35	31
ud	User Definition	32
	Parameter Description – ud. 0/1/2/3/4/6	32
	Parameter Description – ud. 7	33
Fr	Free-programmable	33
	Parameter Description – Fr. 0/1	33
An	Analog I/O	34
	Parameter Description – An. 14/15/16/17	34
di	Digital Input	35
	Parameter Description – di. 0/1	35
	Parameter Description – di. 2/3/15/16	36
do	Digital Output	37
	Parameter Description – do. 0	37
	Parameter Description – do. 1/2/3/9/10/11/17/18/19/25	38
LE	Level	39
	Parameter Description – LE. 8/9/10/12/13/14/24/25/26/32/38	39
In	Information	40
	Parameter Description – In. 0/1/4	40
	Parameter Description – In. 5/6/7/8/9/10/11/12/13/40/41/42/43/44	41

1 Safety Instructions

General

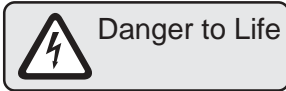

R4-S-regenerative units contain dangerous voltages which can cause death or serious injury. Care should be taken to ensure correct and safe operation to minimise risk to personal and equipment.

If connected inverter at the R4-S-regenerative unit are running regenerative, and the turn-off time of the R4-S-regenerative unit (parameter Pn.59) is adjusted > 0 s, dangerous high voltage will be supplied to the terminals of the R4-S-regenerative unit during mains failure. Therefore a dangerous high voltage for the time of Pn.59 can still be in the system, even after the power supply system is switched off.

Before any working with the unit, control the safe isolation from supply. (with measurements in the unit).

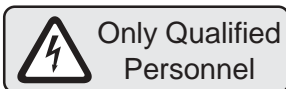

All work from the transport, to installation and start-up as well as maintenance may only be done by qualified personnel (IEC 364 and/or CENELEC HD 384 (VDE 0100) and note national safety regulations). According to this manual qualified staff means:

- *those who are able to recognise and judge the possible dangers based on their technical training and experience*
- *those with knowledge of the relevant standards and who are familiar with the field of power transmission (EN 50178 (VDE 0100 VDE 0160, EN 60204 (VDE 0113)) as well as the appropriate regulations for your area.*

Use as directed

R4-S-regenerative units serves for feeding back energy from the DC-bus circuits of frequency inverters.

Operation with R4-S-regenerative units is only allowed in connection with frequency inverters. Connection of other electrical consumer of the R4-S-regenerative units is not allowed and the unit can be destroyed .

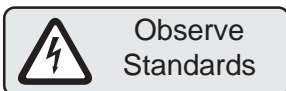

The R4-S-regenerative unit must not be started until it is determined that the installation complies with 89/392/EEC (machine directive) as well as the EMC-directive 89/336/EEC.

The regenerative units meet the requirements of the Low-Voltage Directive 73/231/EEC. The harmonized standards of the series EN 50178 (VDE 0160) in connection with EN 60439-1 (VDE 0660 Part 500) and EN 60146 (VDE 0558) were used.



Transport and Storage

The R4-S-regenerative units must be protected against physical damage during transport, installation and use. Components and covers must not bent or moved as this may affect insulation distances.

The equipment must not be switched on if it is damaged as it may no longer comply with mandatory standards. This equipment contains electrostatic sensitive devices which may be damaged by careless handling.

Installation

Make sure that during installation there is enough minimum clearance and enough cooling. Climatic conditions must be observed in accordance with EN 50178.

Electrical Connection

Before any installation and connection work, the system must be switched off and secured.

After clearing the R4-S-regenerative unit the DC-bus circuit capacitors are still charged with high voltage for a short period of time. The unit can be worked on again, after it has been switched off for 5 minutes.

Connection of the R4-S-regenerative unit is only permissible on symmetrical networks with a maximum line voltage (L1,L2,L3) with respect to earth (N/PE) of 290V.

The R4-S-regenerative unit is only designed for a fixed connection, because when using filters a leakage current >3,5 mA can occur. Protective conductor cross section must be at least 10mm² copper or a 2nd conductor must be electrically parallel to the protective conductor on separate terminals.

When doing an insulation measurement in accordance with EN 60204 (VDE 0113) the power semiconductor of the unit must be disconnected because of the danger of destruction. This is permissible in compliance with the standard, since all inverters are given a high voltage test in the end control at KEB in accordance with EN 50178 (VDE 0160).

When using components without isolated inputs/outputs, it is necessary that equipotential bonding exists between the components to be connected (e.g. through the equalizer). Disregard can cause destruction of the components by the equalizing currents.

A trouble-free and safe operation of the R4-S-regenerative unit is only guaranteed when the connection instructions below are strictly followed. Incorrect operation or damage may result from incorrect installation.

- Note mains voltage and rated motor voltage!
- Install power cables and control cables separately (> 15 cm)!
- Use shielded/twisted control lines. Connect shield to PE at R4-S-regenerative unit only!
- Only use suitable circuit elements to control the logic and analog inputs, whose contacts are rated for extra-low-voltages!
- Make sure housing of the R4-S-regenerative unit is well grounded. The screen of the cable between the inverter and the motor must be directly and securely attached to both the inverter PE terminal and the motor ground terminal. Remove paint finish where necessary!
- Ground the cabinet or the system earth star point with the shortest connection to mains earth (avoid earth loops).

If connecting of additional transformers is necessary, their impedance must be selected as small as possible (short circuit voltage max. 2,5%)!

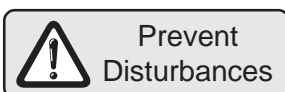
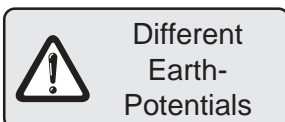
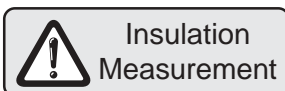
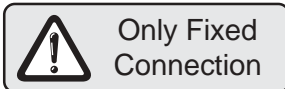
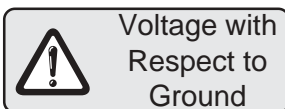
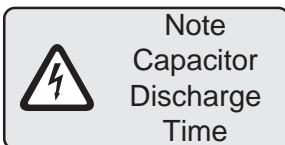

Safety Instructions

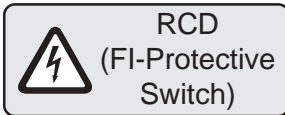

If personnel protection is required during installation of the system the frequency inverters must be protected according to EN 50178 (VDE 0160):

- *3-phase inverters by RCMA's with separation (used privileged) or RCD's type B (all-current sensitive FI's)*

The tripping current should be 300mA or more, in order to avoid a premature triggering of the inverter by discharge currents (about 200mA).

Dependent on the load, the length of the motor cable and the use of a radio interference filter, substantially higher leakage current can occur.

The connection instructions from the manufacturer and the valid local requirements must be observed.

Dependent on the available mains form (TN, IT, TT) further protective measures are necessary in accordance with VDE Part 410 (Part 4; Chapter 41). For example, with TN-mains this protection is made with overcurrent protective devices. With IT-mains it is insulation monitoring with a pulse-code measuring method. A protective separation can be used with all mains forms as long as the required power and cable lengths permit this.

Operating Instructions

Before starting, all respective enclosures must be secured again, as well as the terminals and screws must be checked to see that they are securely fixed.

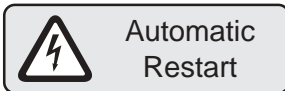

The R4-S-regenerative unit may be set, dependent on type, to restart automatically following a fault stoppage (e.g. Undervoltage Error), when the fault conditions clear. System design must take this into account, if appropriate, and additional monitoring or protective features added where necessary.

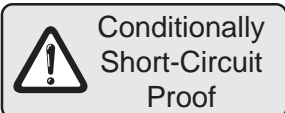

The R4-S-regenerative units are conditionally short-circuit proof (EN 50178/ VDE 0160). After resetting the internal protection devices, the function as directed is guaranteed. Exceptions:

- *If an earth-leakage fault or short-circuit often occurs at the output, this can lead to a defect in the unit.*
- *If a short-circuit occurs during regenerative operation, this can lead to a defect in the unit.*

2 Product Description

2.1 Us as instucted

The R4-S-regenerative unit is qualified for energy feedback in connection with nearly all standard frequency inverters of 200V/ 400 V-Class.

These should be used when motors are connected to frequency inverters and because of the special conditions operate in a regenerative mode and a braking module with braking resistor converts energie in unused heat.

2.2 Field Conditions

The R4-S-regenerative unit can be used if the following conditions are given:

- 3-phase - 180-260 V/ 300–504 V -mains/40–60 Hz
- frequency inverter driven three-phase induction motors
- Inverter with accessable DC-bus link
- partial or permanent regenerative operating

2.3 Device identification

18.R4.S0G–3401

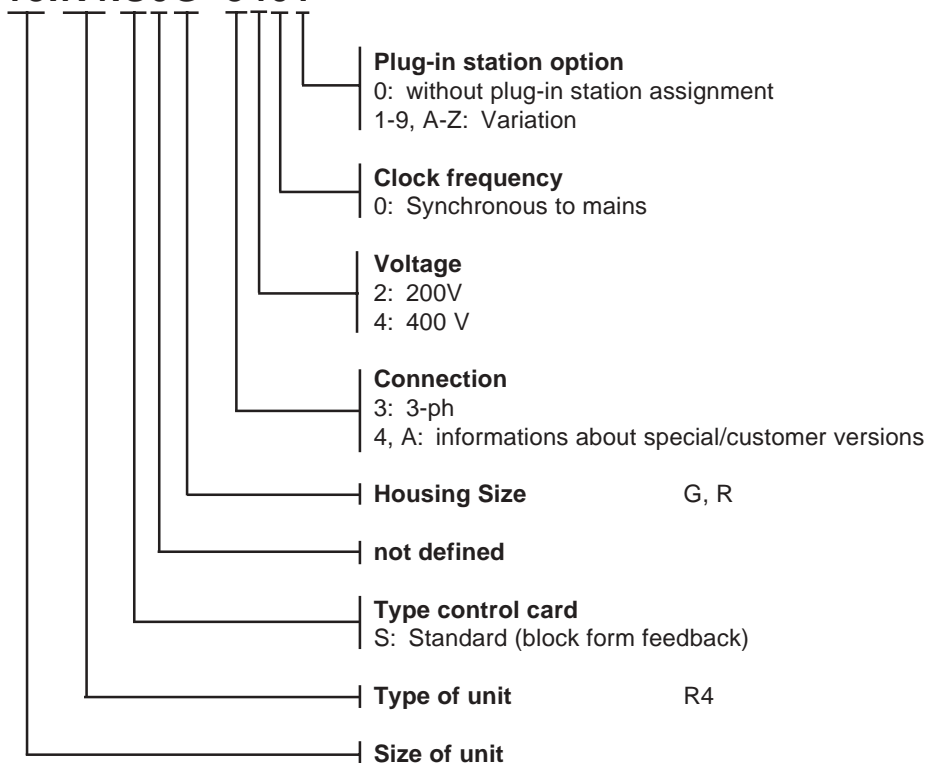

Product Description

2.4 Technical Data

Voltage class		200V		400V		
Part number		12.R4.S0G.3201	15.R4.S0G.3201	14.R4.S0G-3401	18.R4.S0G-3401	22.R4.S0R-3401
Mains voltage	U_{main}	180 ... 260V AC +/-0V		300 ... 504V AC +/-0V		
Mains frequency	f_{main}	40 ... 60 Hz \pm 5%				
Phases		3				
Recovering Operation)						
Reg. Nominal power CE/UL	S_N	7 kVA	15,5kVA/12,5kVA	13 kVA	31kVA / 25 kVA	83 kVA
	P_N	5,5 kW	13,5kW / 11kW	11 kW	27kW / 21,5kW	70 kW
Max. reg. Power	S_{max}	9,5 kVA	22,5 kVA	19 kVA	45 kVA	120 kVA
	P_{max}	8 kW	19,5 kW	16,5 kW	39 kW	100 kW
Reg. Nom. Current (100%ED) CE/UL	I_N	19 A	45A / 36 A	19 A	45A / 36 A	120 A
	I_{DC}	23 A	55A / 40 A	23 A	55A / 40 A	145 A
Short time current	I_{max}	27 A	65 A	27 A	65 A	173 A
70% duty cycle/cycle time 85s	$I_{DC max}$	34 A	80 A	34 A	80 A	210 A
Peak current OC	I_{OC}	31 A	72 A	31 A	72 A	192 A
Supply Operation						
DC-Bus load current (100%ED) CE/UL	I_{DC}	43 A / 40 A	57 A / 40 A	43 A / 40 A	57 A / 40 A	150 A
max. DC-Bus load current (70% duty cycle / cycle time 85s)	I_{DCmax}	49 A	65 A	49 A	65 A	170 A
Control connections						
Voltage range to supply the digital inputs	U_{dig}	13 ... 30 V DC				
internal voltage supply	U_{out}	18 V DC				
max. Output current	I_{out}	300 mA				
external voltage supply	U_{in}	24 V DC / -10%, +25%				
Limiting continuous current	I_{mR}	1A				
max. switching voltage	U_{mR}	30V DC				
Installation						
Operating temperature	T_B	-10 ... 45 °C				
Storage temperature	T_S	-25 ... 70 °C				
Rel. humidity (without condensation)		max. 95%				
Dimensions A x B x C	mm	170 x 340 x 255				340x520x350
Mains line cross section for UL		4mm ² AWG 12	10mm ² AWG 8	4mm ² AWG 12	10mm ² AWG 8	50mm ² AWG 1
DC- Bus line cross section for UL		10mm ² AWG 8	16mm ² AWG 6	10mm ² AWG 8	16mm ² AWG 6	70mm ² AWG 1/0
ext. Input fuse (class gL) for UL		25 A	50 A	25 A	50 A	160 A
ext. DC-Bus fuse (class gR) for UL		14.U4.2R4-3W00 50 A	18.U4.2R4-3W00 100 A	14.U4.2R4-3W00 50 A	18.U4.2R4-3W00 100 A	22.U4.2R4-3W00 2x 110 A
Leakage current		ca.10 mA				ca. 30 mA
Model / protective system		IP 20				
Coefficient	η	> 98 %				
Commutating choke ext. 100% duty choke100%ED		14.DR.R08-3051	18.DR.R08-1351	14.DR.R08-3051	18.DR.R08-1351	22.DR.R08-4841
Commutating choke ext 90% duty cycle / cycle time 60min		—	18.DR.R09-0360	—	18.DR.R09-0360	—
HF Filter (R4) ext. 1 Unit 2 Units parallel		14.R4.T60-1019	18.R4.T60-1019 21.R4.T60-1019	14.R4.T60-1019	18.R4.T60-1019 21.R4.T60-1019	22.R4.T60-1019 25.R4.T60-1019

3 Transport and Storage

The storage of the R4-S-regenerative unit must be done in its original packing. Protect the R4-S regenerative unit against moisture and cold and warm effects.

The transport over long distances must be done in the original packing. Protect the R4-S-feedback against impact load.

Please note the identifying marking at the packing!

After removing of the packing for the installation the R4-S-regenerative unit must stay on a steady base.

4 Installation

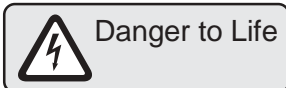
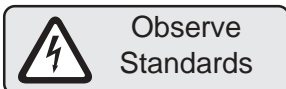
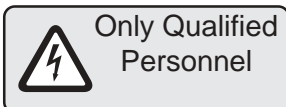

Installation and start-up of the R4-S-regenerative unit is only allowed by qualified personnel. Safe and trouble-free operation is only possible with the following standards: DIN VDE 0100, DIN VDE 0113, DIN VDE 0160, DIN VDE 0875 and other relevant local conditions. The unit must be earthed via the protective conductor. The power terminals L1_2, L2_2 and L3_2 and the terminals for synchronization (L1, L2, L3) must be executed with shielded lines.

Attention, the terminals L1, L2, L3, and -IN, -OUT, +OUT, +IN and L1_2, L2_2, L3_2 do have high dangerous voltages when they are ON!

All installation and connection work must be done in a off circuit status!

A view minutes after switching off the D.C.-bus of the R4-S-regenerative unit has a high voltage. Working at the unit is only allowed after 5 minutes.

Installation

4.1 Installation of the Unit

4.1.1 Measurements

Housing	A	B	C	F	G	H	Weight
G	170	340	255	7	150	330	10 kg
R	340	520	355	10	300	495	28 kg

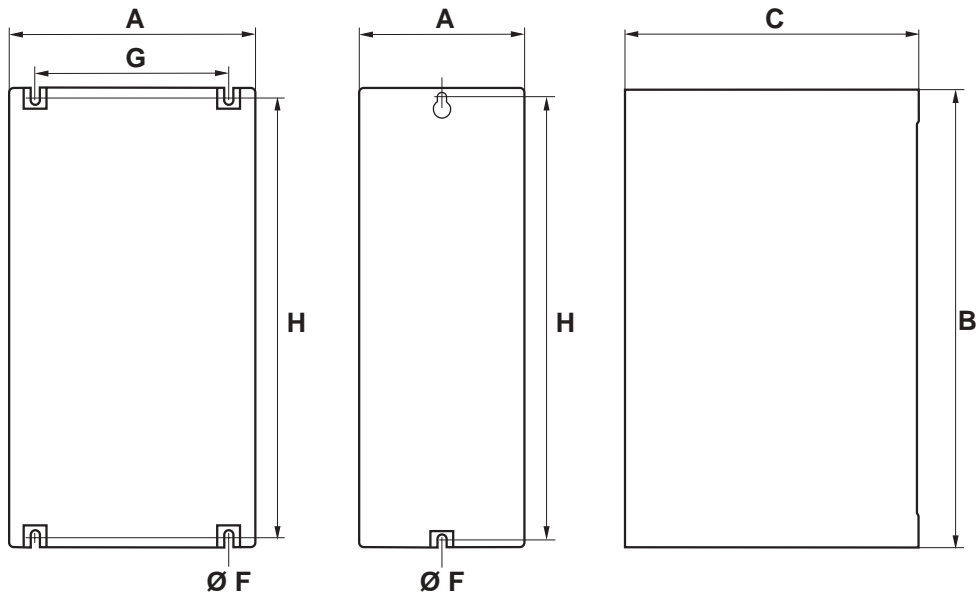

Radio interference suppression filter

Type	A	B	C	F	G	H	Weight
14.R4.T60-1019	80	340	200	6,5	50	320	ca. 6 kg
18.R4.T60-1019	120	340	230	6,5	100	320	ca. 8,5 kg
21.R4.T60-1019	140	460	234	6,5	100	450	ca. 16 kg
22.R4.T60-1019	270	695	130	16	230	655	ca. 29 kg
25.R4.T60-1019	on request						

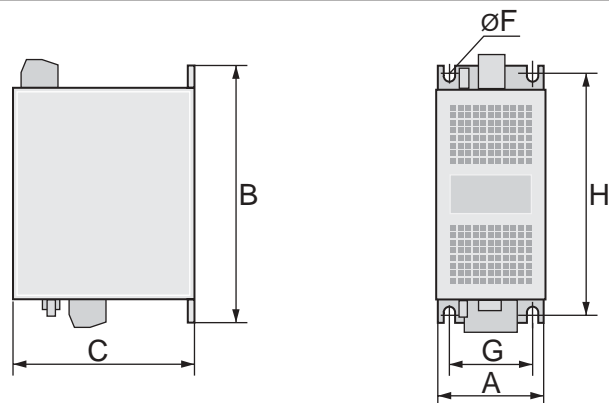

Commutating choke							
Type	A	B	C	F	G	H	Weight
14.DR.R08-3051	120	188	190	15	78	170	9,4 kg
18.DR.R08-1351	180	260	230	15	122	180	23,8 kg
18.DR.R09-0360	70	175	155	12	55	130	4,4 kg
22.DR.R08-4841	205	350	300	15	130	240	53,5 kg

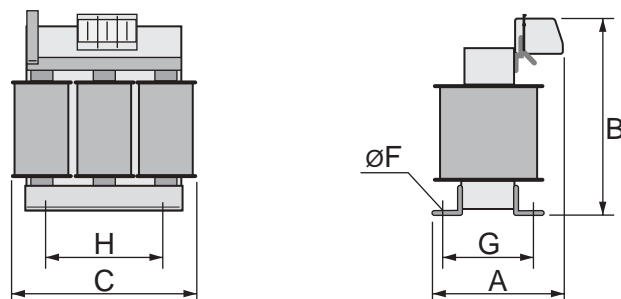

4.1.2 Installation Instructions

The R4-S-regenerative unit is designed for a installation in a vertical control cabinet.

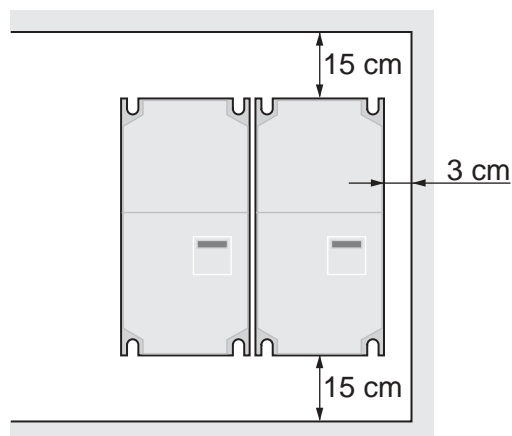

15 cm min. distance at air inlet and air outlet to the next subassembly

R4-S-regenerative units in G-housing can be mounted side to side without min. clearance.

The same applies to combination with frequency inverter in G-housing.

4.2 Connection of the power circuit

Terminal strip housing G

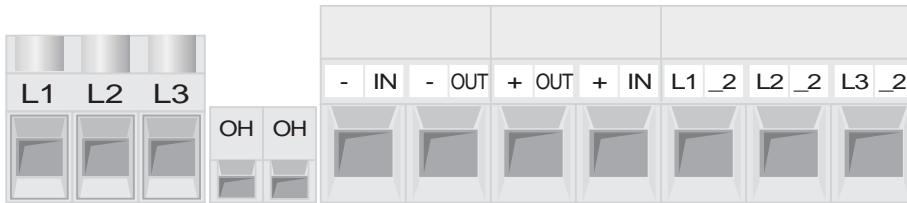

Terminal strip housing R

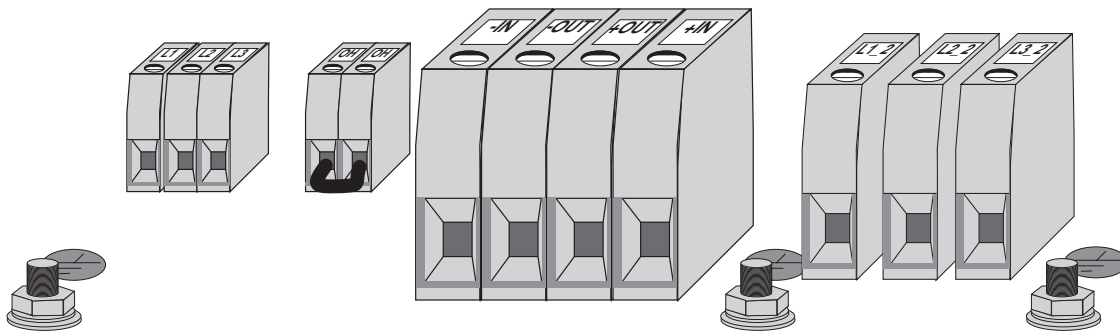

L1, L2, L3	Synchronization
OH, OH	Connection temperature sensor for commutating choke
-IN, +IN	Input DC-bus
-OUT, +OUT	In- / Output DC-bus
L1_2, L2_2, L3_2	3-phase mains connection
PE, 	Connection for shielding/earthing

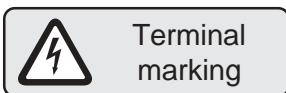

The terminal markings $-U_{ZK}$ and $+U_{ZK}$ are used in the following connection pictures. They show the different terminal markings of the DC-bus, according to the respective KEB inverter type and inverter of other manufacturers.

Temperature Monitoring Commutating Chokes

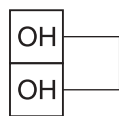

Bridge, when there is no monitoring

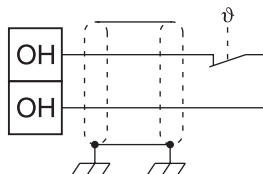

Thermo contact (Break contact)

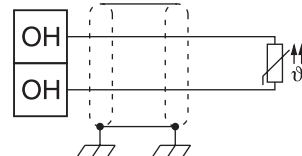

Temperature detector (PTC)
Operate resistor 1,65...4 kOhm
Resetting resistor 0,75...1,65 kOhm
(according to VDE 0660 part 302)

4.2.1 Standard Connection

The R4-S-regenerative unit must be protected on the three input lines (utilization category gL) and in the DC-bus with semiconductor fuses (utilization category gR). The values of the fuses are described in the table 2.4 'technical data'. The semiconductor fuses are sized for a protection of the semiconductors but they don't have the function to protect conductor cross-sections. To avoid invalid, high commutation notches, a commutating choke (Art.No: see 2.4 Technical data) must be connected on line side. The connection of the synchronization lines must be executed via back-up fuses with max. 4A (according to VDE power protection) with twisted cable 0,75 mm². When using a KEB HF-Filter (R4) (Art.No: see 2.4 Technical data) the protection for synchronization connections are not required.

Synchronisation: L1, L2, L3 -mains with L1, L2, L3 the R4-S-regenerative unit;
 Pay attention to correct phase sequence assignment of L1, L2, L3 and L1_2, L2_2, L3_2 !

$$I_{\text{nom. inverter}} \leq I_{\text{nom. feedback unit}}$$

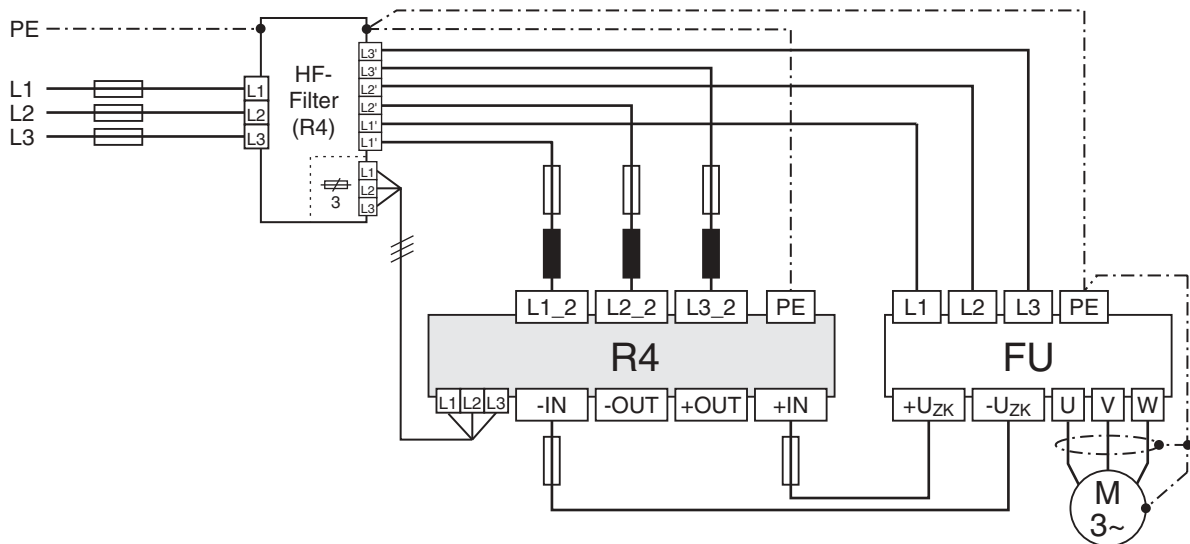

$$I_{\text{nom. inverter}} > I_{\text{nom. feedback}}$$

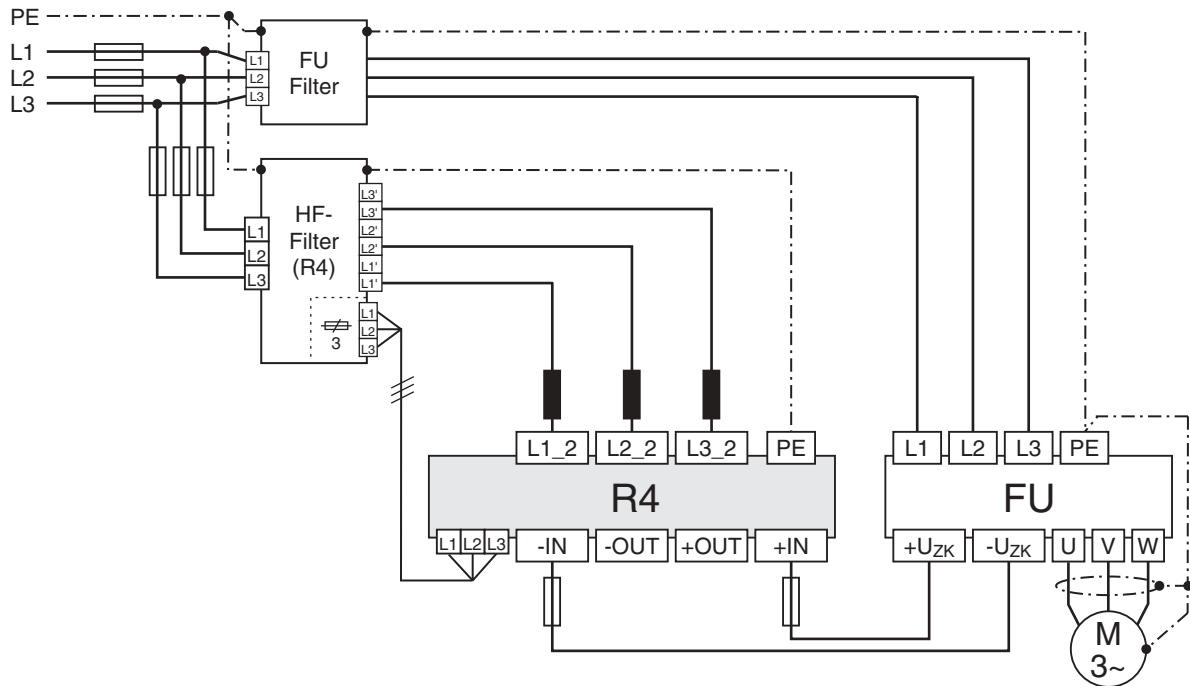

4.2.2 Parallel Operation

If the expected feedback power is higher than the rated power of a R4-S-regenerative unit, the feedback power can be increased by cascading of two or more R4-S-regenerative units. In this constellation the feedback power is increased by the value of the rated power of the additional R4-S-regenerative units.

During parallel operation an own commutating choke must be connected to every R4-S-regenerative unit. The fuses must be set in front of the terminal connection of the DC-bus for protection against the short-circuit current (see chapter 4.3 Connection of the control - parallel operation of several R4-S-regenerative units).

$$I_{\text{nom. inverter}} \leq \sum I_{\text{nom. feedback}}$$

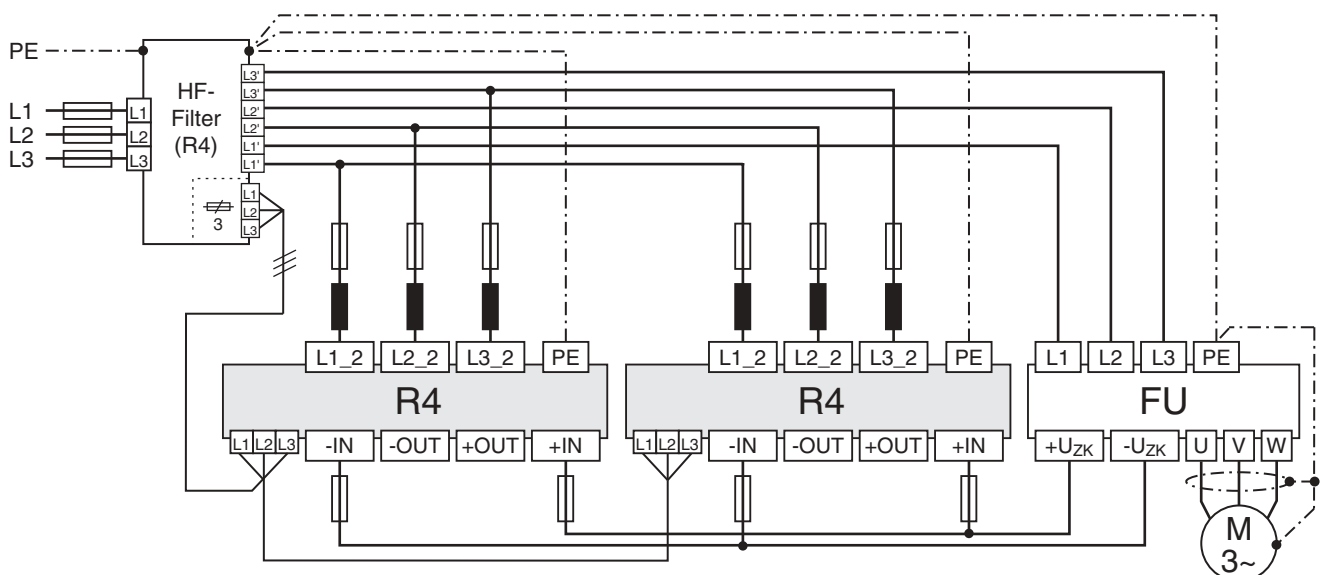

4.2.3 R4-S as feedback and supply unit

Additionally to the feedback function the R4-S-regenerative unit can be used as a B6-full wave rectifier. In this case the R4-S-regenerative unit serves as a DC-supply for one or several frequency inverters which are running on a common DC-bus. Pay attention to the following notes:

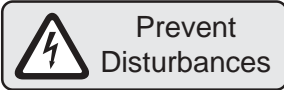

- The connected frequency inverters must be DC-frequency inverters, that means they must have a precharge unit (loading shunt in DC-bus). If the inverter has not a precharge unit in the DC-bus, then the R4-S-regenerative unit will be destroyed.
- Only use the mains commutating choke described by KEB.
- The average value of the taken direct current must not exceed the max. value of the direct current ($I_{DC,MAX}$)!
- In case that the R4-S-regenerative unit is used as regenerative and supply unit, a parallel operation of the R4-S-regenerative unit is not possible!
- If there are several frequency inverters connected to the R4-S Feedback unit, the maximum permissible DC-link capacities of all connected inverters during supply operation must be observed! (see table)

$$I_{\text{nom. feedback}} \geq \sum I_{\text{nom. inverter}}$$

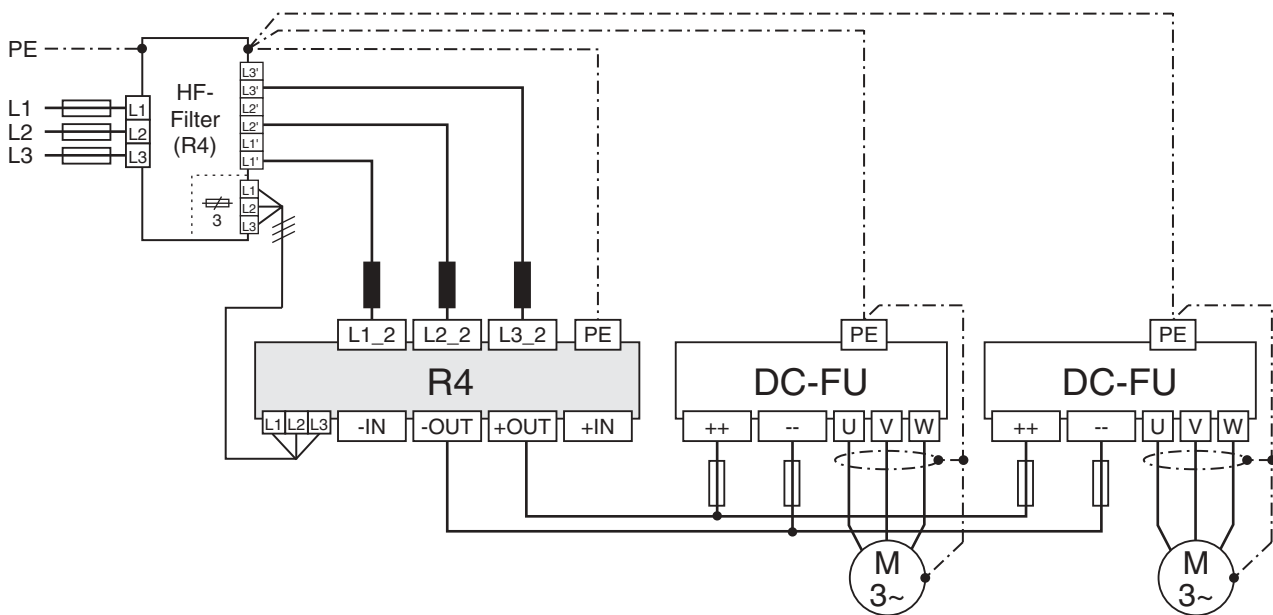

Voltage class		200V			400V	
Part number		12.R4.S0G.3201	15.R4.S0G.3201	14.R4.S0G-3401	18.R4.S0G-3401	22.R4.S0R-3401
max. perm. add. DC-link capacity	µF	3.800	3.500	1.300	1.000	5.000

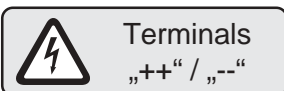

Generally there must be a charging current limit at the input of DC frequency inverter. The terminal markings "++" and "--" are valid for KEB inverter and there can be customer specific variations.

4.2.4 R4-S as Combination with Inverter

The R4-S regenerative unit can be combined with frequency inverters with DC-bus connection (see picture 1). In this case the frequency inverter must be connected to the supply via a separate choke (4 % U_k) (see picture 2).

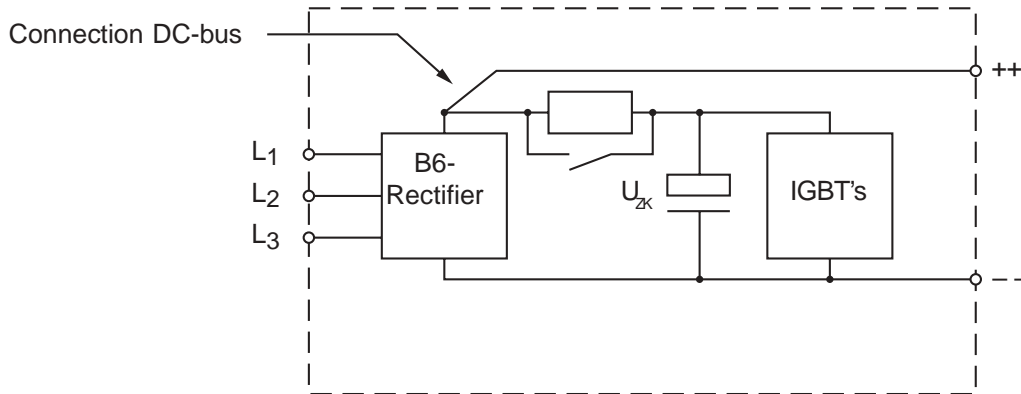

This connection is made for **KEB frequency inverters**, when the d.c. terminals are assigned with '++' and '--'.

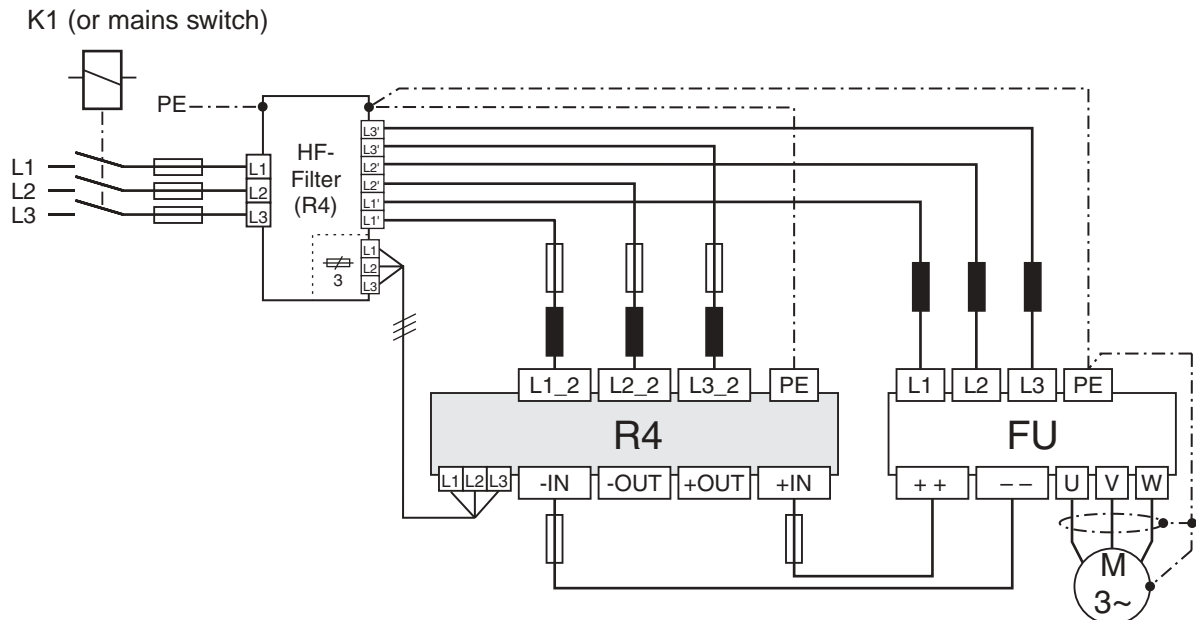

4.2.5 Hints for EMC Conform Wiring

- Install the cabinet or system correctly
- In order to prevent noise interferences
 - a) Mains / supply lines,
 - b) Motor lines from inverters and servo controllers
 - c) Control and data lines (low voltage levels < 48 V), must have a clearance of at least 15 cm when intalled.
- In order to maintain low-resistance high frequency connections, earthing and shielding, as well as other metallic connections (e.g. mounting plate, installed units) must be in metal-to-metal contact with the mounting plate, with a large contact surface. Use earthing and equipotential lines with a section as large as possible (min. 10 mm²) or use thick earthing strips.
- If external interference suppression filters are used, then these must be installed as close as possible to (<30cmfrom) the interference source and in metal-to-metal contact with the mounting plate, with a large contact surface.
- Always equip inductive control elements (contactors, relays etc.) with suppressors such as varistors, RC-elements or damping diodes.
- All connections must be kept as short as possible and as close as possible to the earth, as free lines work as active and passive antennas.
- Shielded cables should be used if the connecting lines between interference suppression filter and commutating choke or commutating choke and R4-S-regenerative unit are longer than 30 cm. The maximum length of this lines is 1 m.
- Keep connection cables straight (do not bundle). Connect all non-assigned wire on both sides to the protective conductor.
- The flow and return circuit must be twisted when the lines are not shielded, in order to dampen common-mode noise.



See the following pages for a correct intallation and wiring of an EMC control cabinet.

Installation of an EMC Conform Cabinet

- 1 Mains fuse
- 2 Main contactor
- 3 Radio interference suppression filter
- 4 Commutating choke
- 5 R4-S-feedback unit
- 6 DC-bus voltage
- 7 Frequency inverter
- 8 Motor table
- 9 Supporting plate is common star point (PE)
- 9a Star point (PE) for control range
- 10 Equipotential earthing
- 13 Mains connection
- 13a Mains connection Control part
- 14 Control lines
-  large contact surface to housing

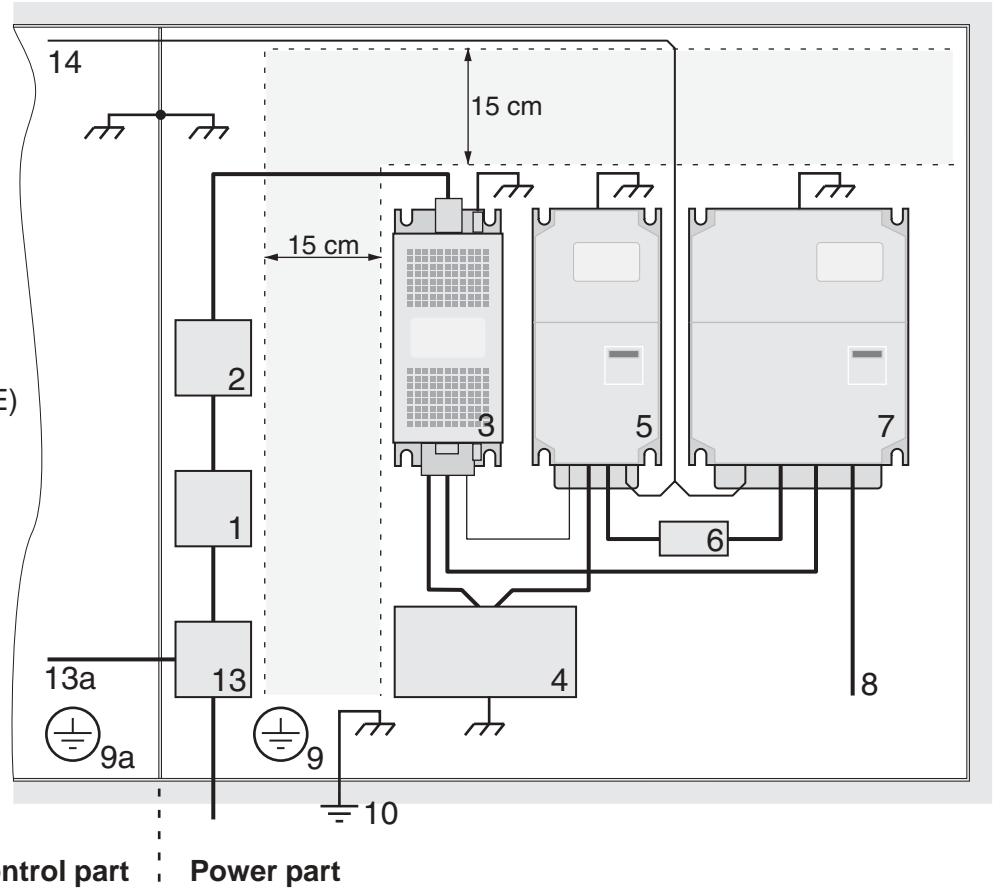

The installation diagram shows the optimum arrangement solution of the units. This diagram should be followed if the dimensions of the control cabinet allowed this .

Installation principle (for compact arrangement of individual subassembly)

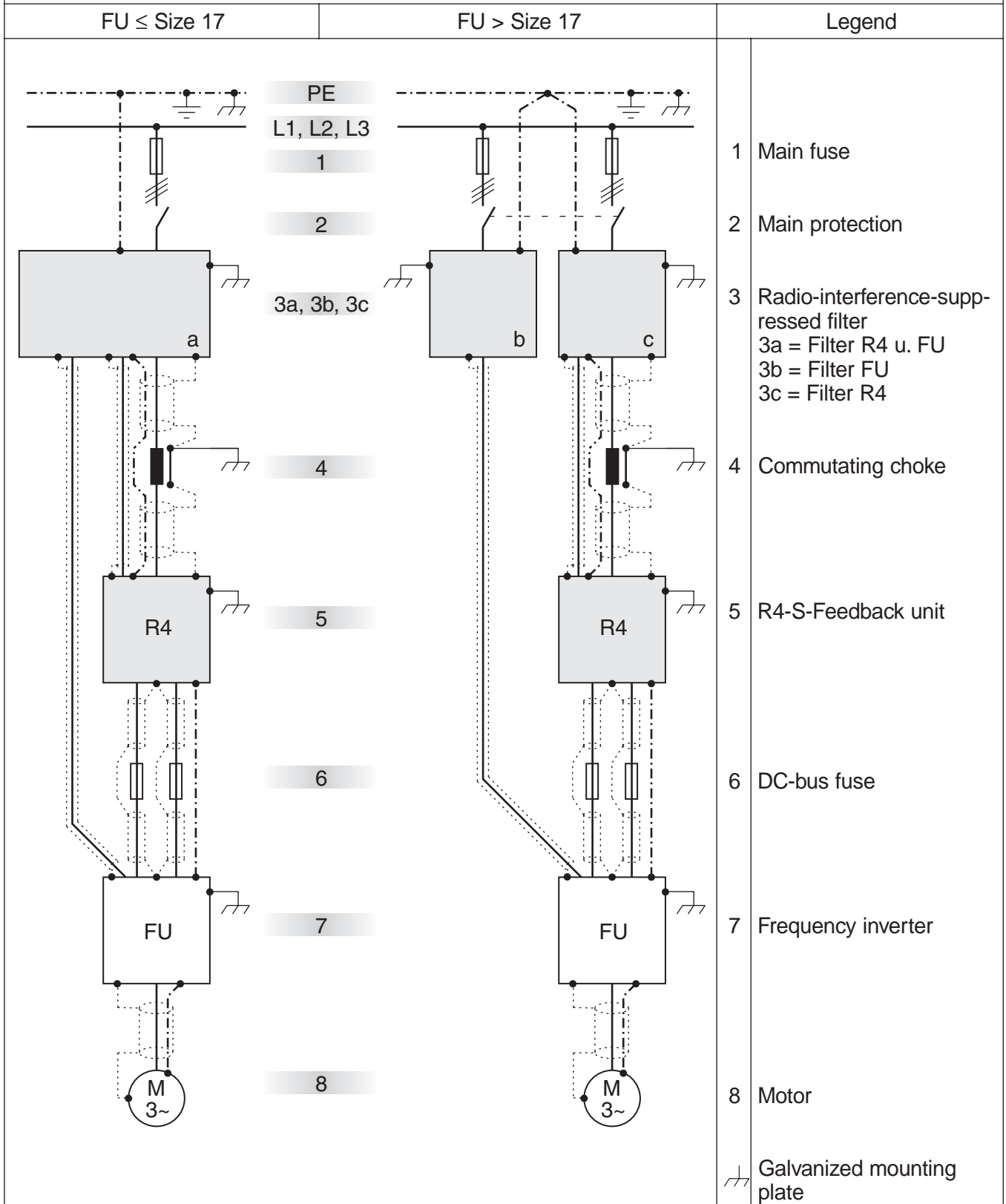

Installation

4.3 Connection of the Control

The connections of all control signals are on the front side of the control card on terminal strip X1.



Digital Inputs – Internal Voltage Supply

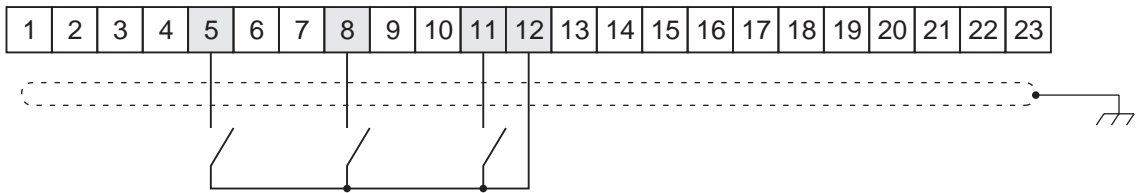

Digital Inputs – External Voltage Supply

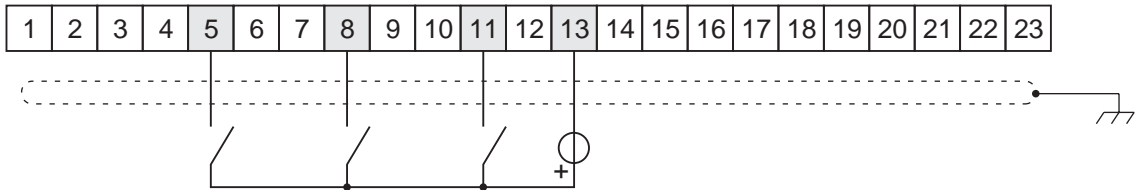

Digital/analog Outputs

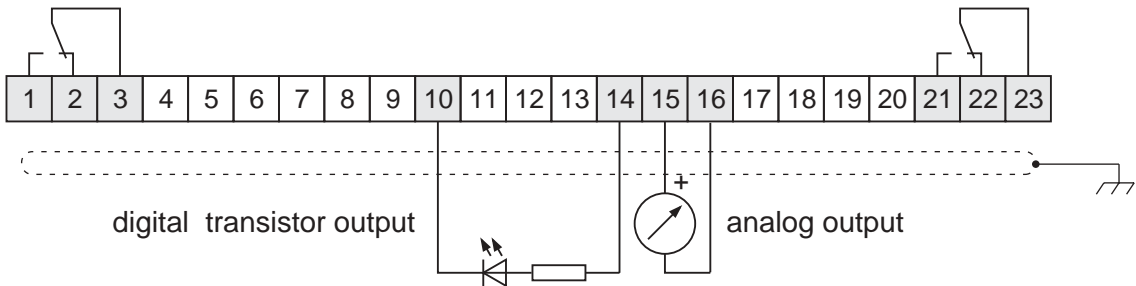

Parallel Operation of several R4-S-regenerative units

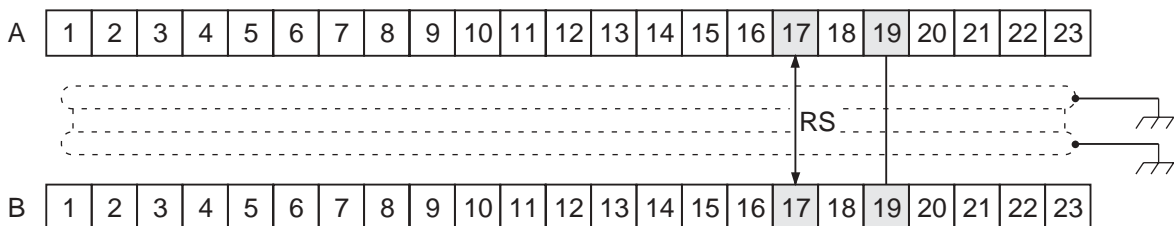

4.3.1 Terminal Assignment X1

Term.		Function	Description
X1.1 X1.2 X1.3	FLA FLB FLC	Relay output 1 (OUT 1) <i>Default:</i> <i>Ready-Relay</i>	Potential-free, programmable relay output with Changeover contact (X1.1, X1.2, X1.3), NC contact (X1.2, X1.3), NO contact (X1.1, X1.3), max 1A
X1.4	free		
X1.5	IN_DIG	Digital input <i>no function</i>	Programmable, potential-free digital input for the status evaluation of host controls (SPS) *
X1.6	24 V OUT	Control voltage	Potential-free voltage source for external control module supply
X1.7	EXTGND	Reference point	Ground for all external control module
X1.8	ST	Control release	Release of the modulation of the R4-S at +24 V. Additionally a reset of operating errors is done with every leading edge *
X1.9	24 V OUT	Control voltage	see X1.6
X1.10	EXTGND	Reference point	see X1.7
X1.11	RST	Reset	Reset of fault status (leading edge-triggered). *
X1.12	24 V OUT	Control voltage	see X1.6
X1.13	EXTGND	Reference point	see X1.7
X1.14	DOUT	Digital output (OUT 3), <i>Default: Fatal Error</i>	Isolated, programmable transistor output for status indication of the R4-S to host control (PNP-Logic). max. 20mA
X1.15	AN_OUT	Analog output <i>Default:</i> <i>actual load</i>	Programmable analog output, which supplies a proportional voltage signal of 0 V to 10 V.
X1.16	GND	Reference point	Reference point for terminal X1.15 (X1.15, X1.16 non-isolated)
X1.17	RS	Active-Signal	During parallel operation all R4-S are switched at the same time in the Master-Slave-Process to feedback operation (isolated).
X1.18	24 V IN	External voltage supply	External voltage supply (+24V to +30V) for the dig. I/O's- control card and sensors. If ext. components are supplied with > 300 mA at 24 V OUT, an ext. voltage supply must be made available at terminal X1.18
X1.19	EXTGND	Reference point	See X1.7
X1.20	free		
X1.21 X1.22 X1.23	RLA RLB RLC	Relay output 2 (OUT 2) <i>Default:</i> <i>Error message</i>	Potential-free, programmable relay output with: Changeover contact (X1.21, X1.22, X1.23), NC contact (X1.22, X1.23), NO contact (X1.21, X1.23), max. 1 A
*The control logic of the digital input can be changed with parameter di. 1.			

5 Operating the Unit

5.1 Initialization

- Initialization** After connection to the mains supply the R4-S-regenerative unit is initialized. First the power part is identified. The error message „E.PUC” (Power Unit Check) is displayed when there is an unvalid power part. A reset of this error is not possible, the power part must be checked.
- Status „SYn“** The R4-S-regenerative unit goes into status „SYn” when there is a valid power part. During this synchronisation phase the following processes are running:
1. Check the correct synchronisation connection, (if the synchron signal is missing, the error „E.nEt” is displayed)
 2. Check the phase assignment of synchron signals to the mains phases. Error message „E.SYn” is displayed when one phase is missing or when there is a phase assignment error.
- After synchronisation the actual mains frequency is set and the connection of the R4-S-regenerative unit is correct. If the release signal (terminal ST) is set, the R4-S-regenerative unit takes independently its function. Dependent on the actual demand the R4-S-regenerative unit is in the status „Active” or „Stdby”.
- Status „Stdby“** The R4-S-regenerative unit defects a normal voltage level in the DC-bus of the connected frequency inverter (mot. operation) and the modulation signals of the R4-S-regenerative unit are not active.
- Status „Activ“** The modulation signals become active and the unit goes into feedback operation when there is an overvoltage. The R4-S-regenerative unit is active, also if another R4-S-regenerative unit in the system demands a feedback operation (Signal RS=1).

5.2 Operation during the Unit is running

Generally there are two options of operation with the R4-S-regenerative unit:

1. Operation with interface-operator
2. Operation with personal computer and system software COMBIVIS

5.2.1 Operation with Interface-Operator

- Local Operation** For local operation of the R4-S-regenerative unit an operator is necessary. To prevent malfunctions, the inverter must be brought into "noP" status (control release terminal X1.8 open). A start of the R4-S-regenerative unit without operator is done with the last stored values or with factory setting. A LED-display shows all operating conditions of the R4-S-regenerative unit. With four keys you can initiate operating parameters or adjustment changes of different operating conditions can be done. Also a password input is possible.
- BUS- Operation** Additionally the operator has a 9-pole RS232/485 interface, which serves for communication with a data transfer device.

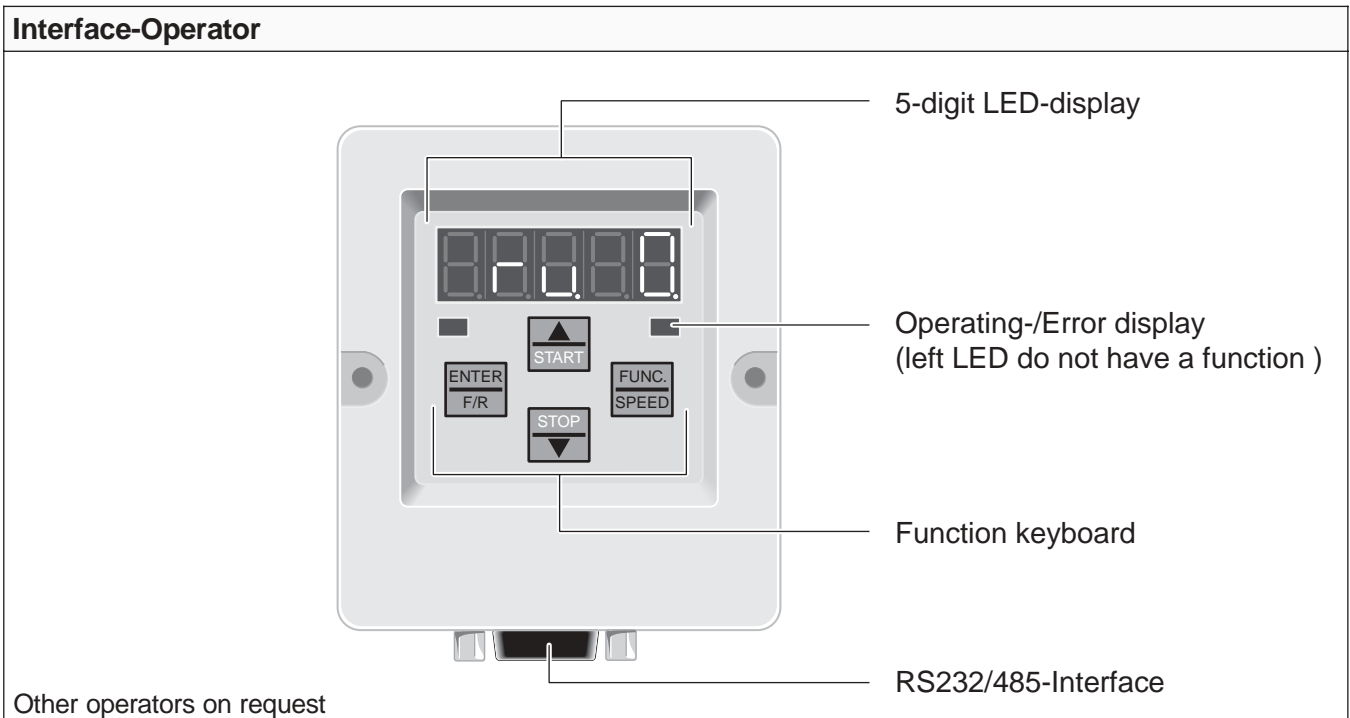

Isolated RS232/485-Interface

Pin	RS485	Signal	Meaning
1	-	-	reserved
2	-	TxD	Transmitter signal/RS232
3	-	RxD	Receiver signal/RS232
4	A'	RxD-A	Receiver signal A/RS485
5	B'	RxD-B	Receiver signal B/RS485
6	-	VP	Voltage supply +5 V ($I_{max} = 10 \text{ mA}$)
7	C/C'	DGND	Data reference potential
8	A	TxD-A	Transmitter signal A/RS485
9	B	TxD-B	Transmitter signal B/RS485

5.2.2 Operating with PC and System software COMBIVIS

Please refer to the relating software description for installation and operating of the system software COMBIVIS.

5.3 Keyboard Operating

5.3.1 Standard Operating

There are two different operating modes during the operation via keyboard.

Mode 1 Display and change of the parameter identification (number and group)

Mode 2 Display and change of the parameter value

A change between this two modes is possible with the FUNCT-key. That means: The adjusted value is shown by pressing the FUNC-key in mode 2. If you press the FUNC-key again, the parameter identification will be shown.

5.3.1.1 Display of the Parameter Identification

Individual information for parameter identification is separated by dots. One dot flashes and indicates which part can be changed with UP/DOWN. With ENTER the flashing dot can be changed between parameter group and parameter number.

Change of the
Parameter Group

To change the parameter group the ENTER key must be pressed until the dot behind the parameter group flashes. With UP/DOWN the requested parameter group can be adjusted. When the parameter group is changed the parameter number is set to the lowest available parameter number in the new group.

Change of the
Parameter Number

In order to change the parameter number, the flashing dot must be set behind the parameter number. Now you can change the parameter number with UP/DOWN. If the highest parameter of one group is reached and UP is pressed, the lowest parameter number of this group is displayed. If the lowest parameter number is reached and DOWN is pressed, the highest parameter number of this group is displayed. A change of the parameter number does not change the parameter group.

5.3.1.2 Display of the Parameter Value

Change of the Parameter Value In the mode 'parameter value display' the value of the adjusted parameter can be changed by pressing the UP/DOWN keys. Generally, these changes are immediately effective and permanently stored, meaning they remain stored after the unit is switched off. Confirming the input with ENTER is not necessary.

Enter Parameter For some parameters it is recommended that the value adjusted by UP/DOWN does not automatically become valid. These parameters are called ENTER parameters since they must be confirmed by ENTER. When pressing UP/DOWN only the display is changed but not the value stored in the regenerative unit. When the display value is different from the stored value in the regenerative unit, then this is marked by a dot in the display. By pressing ENTER the display value is stored in the R4-s-regenerative unit and the dot is deleted. The parameter value display of an ENTER parameter always starts with the stored value in the R4-S-regenerative unit.

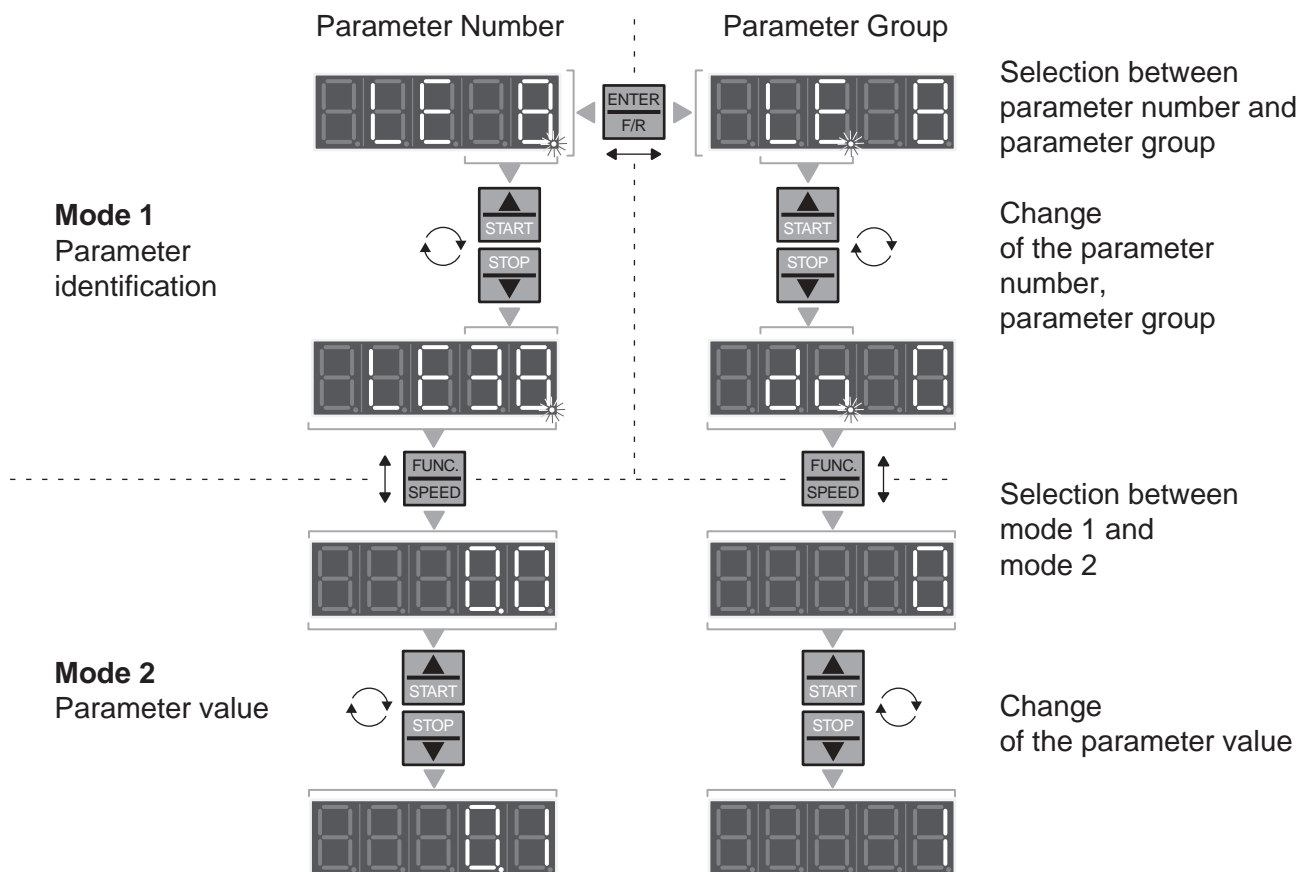

5.3.2 Special Displays

Error Message If a fault occurs during operating the R4-S-regenerative unit, the actual display is overwritten with an error message. This error message flashes. With ENTER the display of the error message is cleared and the last adjusted parameter value is shown. This is not an error reset; that means the fault status in the R4-S-regenerative unit is not reset. Because of that it is possible to correct adjustments before an error reset. An error reset is only possible with the terminals control release or reset.

Feedback Some inputs to the R4-S-regenerative unit are confirmed.

- „PASS“ Factory setting was loaded
- „nc0“ Factory setting could not be loaded

This messages must be confirmed with ENTER.



5.4 Parameter

5.4.1 Parameter Summary

Parameter Group	Short Descr.	Description
Run	ru	Contains all operating displays, i.e.: all values which can change during operation.
Protection	Pn	All protection functions and all keep-on-running-functions (e.g. Auto Restart)
User-definition	ud	All parameter for individual adjustment of operator interface and serial interface
Free-prog.	Fr	Parameter for loading the factory setting
Analog-Out	An	Programming of the analog output
Digital-In	di	Programming of the digital inputs
Digital-Out	do	Programming of the digital outputs
Level	LE	Switching conditions for the digital outputs
Information	In	Information about type, serial number and diagnosis parameter error counter, QS-number etc.
Control	CS	Parameter for controller adjustments

5.4.2 Parameter Description

5.4.2.1 Run (ru) – Parameter

Gr.	No	Name	Addr. (hex)	P	E	ro	Res.	Lower Limit	Upper Limit	Default-Value	Unit
ru	0	Inverter status	2000			•	1	0	122		-
ru	7	Actual load	2007			•	1	0	200		%
ru	8	Peak load	2008				1	0	200		%
ru	9	apparent current	2009			•	0,1	1	n. i.		A
ru	11	DC-bus voltage	200B			•	1	0	1000		V
ru	12	DC-bus voltage/peak value	200C				1	0	1000		V
ru	14	Input terminal status	200E			•	1	0	7		bit
ru	15	Output terminal status	200F			•	1	0	7		bit
ru	16	Internal input status	2010			•	1	0	7		bit
ru	17	Internal output status	2011			•	1	0	7		bit
ru	24	Display OL-counter	2018			•	1	0,0	100		%
ru	29	Heat sink temperature	201D			•	1	0	LTK		°C
ru	52	Display mains frequency	2034			•	0,1	0,0	160,0		Hz

R4-State - ru. 0

The operating state of the R4-S-feedback unit is displayed in the R4 state

Display	Value	Description
noP	0	No Operation: control release is not bridged, modulation off, output voltage = 0
E.OP	1	Over Potential, DC-bus voltage too high
E.UP	2	Under Potential, DC-bus voltage too low
E.OC	4	Over Current, output current > 1,6 x I_{rated}
E.OH	8	Over Heat, overheating of the feedback unit
E.dOH	9	Drive Over Heat, temperature monitoring of the commutating choke has triggered and prewarning time has run out
E.OL	16	Over Load, overload of the feedback unit is running
E.nOL	17	No Over Load, cooling time E.OL has run out, error can be reset
E.EF	31	Extern Fault, error message with external unit
E.nOH	36	No Over Heat, (E.OH or E.dOH), error can be reset
E.PuC	49	Power circuit identifier not valid
bbI	76	Base-block time is running off, R4-S-feedback unit is isolated
E.SYn	115	Faulty synchronization, e.g. phase assignment is not correct
Activ	116	Feedback active (generative operation)
StdbY	118	R4-S-Feedback unit in stand-by-operation (motorized operation)
SYn	120	Check of phase assignment and synchronization on mains angle
nEtOF	121	Mains failure; feedback is further possible
E.nEt	122	Several line phases missed

Operating the Unit

Actual Load – ru. 7

Parameter ru. 7 shows the actual load of the R4-S-feedback in % . 100 % means the output current which corresponds to the rated current of the feedback unit. The amount of the load is displayed. The sign shows the energy direction; (+) = supply, (-) = feedback.

Peak Utilization – ru. 8

ru. 8 makes it possible to immediately detect peak utilization within an operating cycle. In addition the highest value that occurs in ru.7 is stored in ru.8. The peak memory can be deleted by pressing the UP or DOWN key, or with Bus by writing any value onto the address of ru.8. The memory is deleted when the feedback is switched off.

DC Voltage – ru. 11/12

Display of the actual DC-bus voltage with a resolution of 1V. The highest value is stored in ru.12. ru.12. can be deleted by pressing the UP or DOWN key. The peak memory can be deleted via bus by writing of any value to ru.12. ru.12 can be deleted by pressing Power On Reset.

Input Terminal Status – ru. 14

ru. 14 shows the logical status of the input terminals. Logical combinations do not find consideration. If one input is triggered, the corresponding decimal value is displayed. If several inputs are triggered, the sum of the decimal value is displayed.

Bit-No	Decimal Value	Input	Terminal
0	1	ST (Control release)	X1.8
1	2	RST (Reset)	X1.11
2	4	I1 (Prog. Input 1)	X1.5

Output Terminal Status – ru. 15

ru. 15 makes it possible to control the digital outputs. ru. 15 considers the logical combinations of the digital outputs. (do. 0, do. 9 to do. 25).

To every active output the corresponding decimal value is displayed. If several outputs are active, the sum of the decimal values is displayed.

Bit-No	Decimal Value	Input	Terminals
0	1	Out 1 (Relay FLA, FLB, FLC)	X1.1, X1.2, X1.3
1	2	Out 2 (Relay RLA, RLB, RLC)	X1.21, X1.22, X1.23
2	4	Out 3 (Transistor output)	X1.14

Internal Input Status – ru. 16

ru. 16 shows the logical status of the digital inputs, input terminals after logical combination by di-Parameter. If one input is triggered, the corresponding decimal value is displayed. If several inputs are triggered, the sum of the decimal value is displayed.

Bit-No	Decimal Value	Input	Terminals
0	1	ST (Control release)	X1.8
1	2	RST (Reset)	X1.11
2	4	I1 (Prog. Input 1)	X1.5

Internal Output Status – ru. 17

ru. 17 shows the results of the output function table (do. 1 to do. 3) . If one switching condition is met, the corresponding decimal value is displayed. If several switching conditions are met, the sum of the decimal value is displayed.

Bit-No	Decimal Value	Input	Terminals
0	1	Out 1 (Relay FLA, FLB, FLC)	X1.1, X1.2, X1.3
1	2	Out 2 (Relay RLA, RLB, RLC)	X1.21, X1.22, X1.23
2	4	Out 3 (Transistor output)	X1.14

Display OL-Counter – ru. 24

Evaluates the continuous load of the inverter, in order to prevent OL from occurring (load reduction on time). The OL error is triggered, when the OL counter reaches 100%.

Heat Sink Temperature – ru. 29

ru. 29 shows the actual heat sink temperature in °C .

System Frequency – ru. 52

After "Power on" the actual system frequency is determined during initialization. Slow changes of the system frequency during operation are recognized and displayed in ru.52.

5.4.2.2 Protection (Pn) – Parameter

Gr.	No	Name	Add- r. (hex)	P	E	r- o	Res	Lower Limit	Upper Limit	Defau- It Value	Unit
Pn	0	Automatic restart UP	2200				1	0	1	1	
Pn	1	Automatic restart OP	2201				1	0	1	0	
Pn	16	Delay time error E.dOH	2210				1	1	120	60	s
Pn	59	Delay time error E.nEt	223B				0,01	0	10	0	s

Automatic Restart UP/OP – Pn. 0/1

With active function the respective error is reset automatically.

Value	Meaning
0	Function switched off
1	Function switched on

Break Time, Error E.dOH – Pn. 16

With Pn.16 the error E.dOH (over heat of the commutating choke can be delayed after the external signal is set.

Break Time, Error E.nEt – Pn. 59

With Pn.59 the error E.nEt (failure of the mains supply) can be delayed after the external signal is set. Factory setting is 0 seconds.

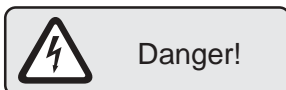

If the time > 0 seconds is adjusted, the modulation is possible for the adjusted time also when the mains lines are disconnected.

In this particular applications special procedures must be done to save personnel protection. For this reason the acces to Pn.59 is password protected.

5.4.2.3 Control (CS) – Parameter

Gr.	No	Name	Addr. (hex)	P	E	r-o	Res.	Lower Limit	Upper Limit	Default Value	Unit
CS	27	Feedback level	2D1B				1	100	120	105	%
CS	35	Controller detent lever	2D23				1	2	30	30	%
CS	39	KEB intern function	-								

Feedback Level – CS. 27

Adjustment in % of the actual supply voltage $\times \sqrt{2}$. The feedback starts to run if the DC-bus voltage overranges the level. The R4-S-feedback unit is into status „active“.

Example:	Adjustment:	CS. 27 = 105 %
	Supply Voltage:	$U_{net} = 400 \text{ V}$
	DC-bus Voltage:	$U_{zK} = U_{net} \times \sqrt{2} = 400 \text{ V} \times \sqrt{2} = 565 \text{ V} = 100 \%$
	Feedback Voltage:	$U_{rück} = (U_{zK} / 100) \times \text{CS. 27}$
		$U_{rück} = (565 / 100) \times 105 = 593 \text{ V}$

Controller – CS. 35

Adjustment in % of the recognized supply frequency (ru. 52). If the actual supply frequency is outside of the detent lever, the R4-S-feedback unit goes to idle operation. Disturbances of the synchronous signal are ignored out of the detent lever.

5.4.2.4 User Definition (ud) – Parameter

Gr.	No	Name	Addr. (hex)	P	E	ro	Res.	Lower Limit	Upper Limit	Default Value	Unit
ud	0	Key password input	2600		•		1	0	9999	0	
ud	1	Bus password input	2601				1	0	9999	0	
ud	2	Start parameter group	2602				tab.	ru	tab.	ru	
ud	3	Start parameter number	2603				tab.	0	99	0	
ud	4	Auto Enter (only for bus-P.)	2604				1	0: off	1: on	1	
ud	6	Inverter address	2606		•		1	0	239	1	
ud	7	Baud rate	2607		•		tab.	1200	19200	9600	baud

Key Password Input – ud. 0

Reserved

Bus Password Input – ud. 1

Reserved

Start Parameter – ud. 2/3

With ud.2 and ud.3 you can select which parameter should be displayed after power-on. The parameter group is adjusted in ud.2 and in ud.3 the parameter number. If a non-available parameter number is adjusted in ud.3, the R4-S-feedback unit starts with the next higher parameter number.

Auto Enter – ud. 4

The parameter memory (EEPROM) of the unit does not allow unlimited numbers of write cycles. The parameter (ud.4) AUTO-SAVE can be set to 0, to extend the parameter memory. After that all written parameter via bus can not be stored!

Switching off the parameter memory is only necessary, if the feedback unit gets continuous new parameter values via bus. In this case a destruction of the memory is to prevent by overranging the maximum number of write cycles to one address.

R4-Address – ud. 6

The address for operation via serial bus (e.g. COMBIVIS) is set by ud.6. Possible addresses are 0...239. The standard address is 1. If more than one feedback units is connected to the bus it is absolutely necessary to assign them different addresses. Otherwise communication disturbances can result, because several R4-S-feedback units response at the same time. For further information see the description of DIN 66019 protocol.

Baud Rate – ud. 7

If the value for the baud rate is changed via serial interface, a change of the value is only possible via keyboard or adjustment of the baud rate of the Master, because communication between different baud rates of Master and Slave is not possible.

Parameter Value	Baud Rate
0	1200 baud
1	2400 baud
2	4800 baud
3	9600 baud
4	19200 baud

5.4.2.5 Free-programmable (Fr) – Parameter

Gr.	No	Name	Addr. (hex)	P	E	ro	Res.	Lower Limit	Upper Limit	Default Value	Unit
Fr	0	Copy keyboard parameter set	2700		•		1	-2: init	-2	-2	
Fr	1	Copy bus parameter set	2701				1	-2: init	-2	-2	

Copy Sets – Fr. 0/1

With function init(-2) you can copy the stored basic settings from the EPROM into the read-only memory. The parameter adjustments are overwritten with the default values. This function can only be done if the R4-S-feedback unit is into status „noP“.

Keyboard – Fr. 0

When the feedback unit is operated via keyboard the copy process is triggered by Fr.0. Fr.0 cannot be seen by bus. The copy process is triggered when the parameter value is confirmed with ENTER. If the copy process has finished, the display shows PASS. If the copy process could not be done nco is displayed. These feedbacks must be conformed with ENTER.

Bus – Fr. 1

With Fr.1 the copy process is triggered via bus Fr. 1 cannot be seen by keyboard.

5.4.2.6 Analog I/O (An) – Parameter

Gr.	No	Name	Addr. (hex)	P	E	ro	Res.	Lower Limit	Upper Limit	Default Value	Unit
An	14	Analog Out 1 Function	280E	•	•		1	0	7	0	
An	15	Analog Out 1 Gain	280F	•			0,01	0	20	1,00	
An	16	Analog Out 1 Offset X	2810	•			0,1	-100	100	0,0	%
An	17	Analog Out 1 Offset Y	2811	•			0,1	-100	100	0,0	%

Analog Out 1 Function – An. 14

This parameter decides which process variables should be visualized.

Parameter value	Process variable	Range of values
0	Rate of loading	0 % to 200 %
1	DC-bus voltage	0 V to 1000 V

Characteristic amplifier of the analog inputs and outputs – An. 15/16/17

The analog output supplies at output value of 100% 10 V voltage .

The characteristic amplifier An.15,16 and 17 have an influence to the characteristic.

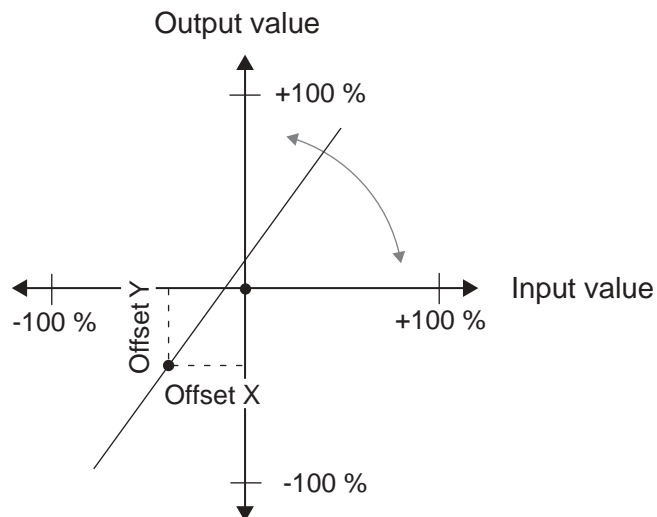

The zeropoint of the characteristic can be defined with offset X (An.16) and offset Y (An.17). In most applications it is sufficient to adjust only one parameter. The rising of the characteristic is determined by the gain.

5.4.2.7 Digital Input (di) – Parameter

Gr.	No	Name	Adr. (hex)	P	E	ro	Res.	Lower Limit	Upper Limit	Default Value	Unit
di	0	Digital noise filter	2900				1	0	31	0	4 ms
di	1	NPN/PNP-selection	2901		•		1	0: pnp	1: npn	0	
di	2	Input logic	2902		•		1	0	7	0	
di	3	Input function I1	2903		•		1	0	1	0	
di	15	Select signal source	290F		•		1	0	7	0	
di	16	Digital input setting	2910		•		1	0	7	0	

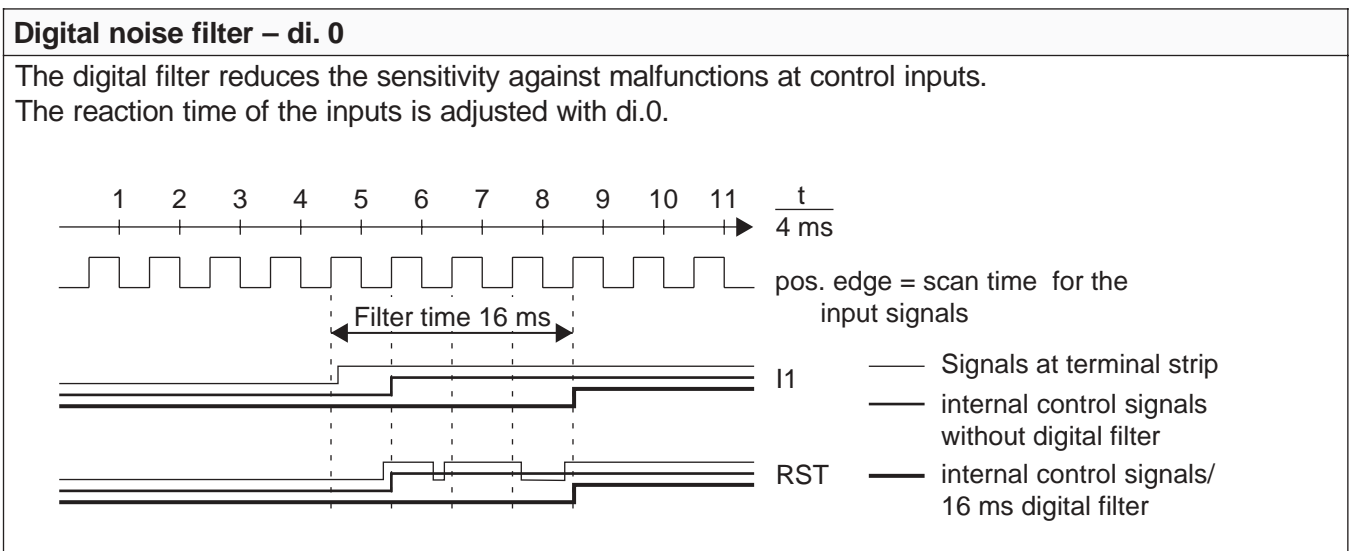
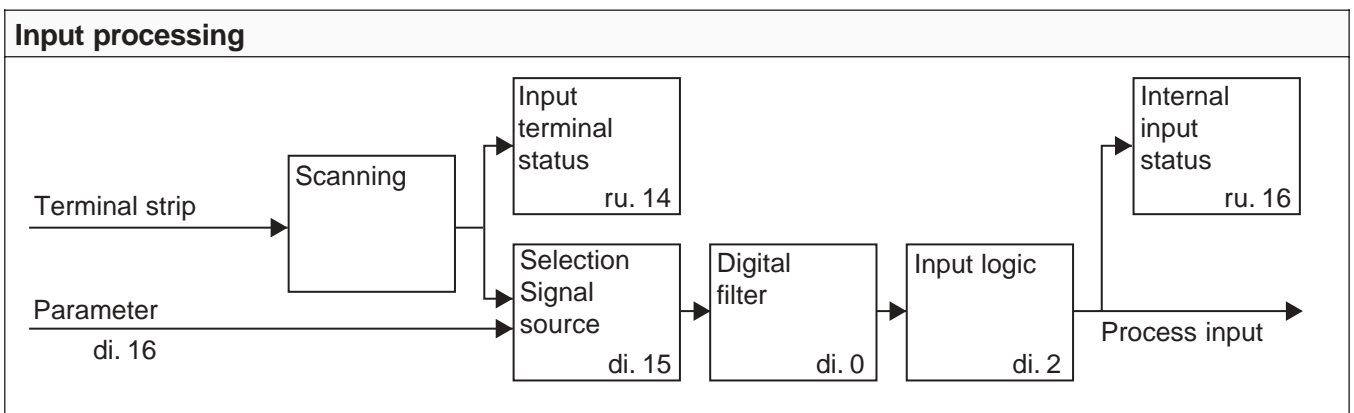

NPN/PNP-Selection – di. 1

Selection of PNP or NPN logic for the input terminals.

Parameter value	Logic of the input terminal
0	PNP
1	NPN

Bit Coded Parameter – di. 2/15/16

With the bit coded di. parameter for each input the respective decimal value is adjusted. If the function should be valid for several inputs, the sum of the decimal value is adjusted. Exception: input ST. Look to the following assignment:

Bit-No.	Decimal value	Input
0	1	ST
1	2	RST
2	4	I1

Input Logic – di. 2

In this parameter you can choose whether the input signal triggers are 1 or 0-active (inverted) . Input ST is not inverted!

Input Function – di. 3

With di.3 the function of the programmable input (I1) is adjusted.

Parameter Value	Input Function
0	no function
1	input triggers external error (E.EF)

Select Signal Source – di. 15

Parameter di.15 selects for each input, whether the state of the terminal strip or the state of parameter di.16 is evaluated.

Digital Input Setting – di. 16

With parameter di. 16 the inputs can be set via software. For this the corresponding inputs must be selected in parameter di.15.

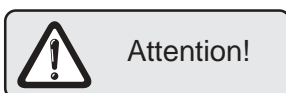

Exception: Input ST. If digital input of control release is adjusted (Bit 0 of di. 15=1), the signal must preset via terminal strip and parameter di. 16 (Bit 0)!

5.4.2.8 Digital Output (do) – Parameter

Gr.	No	Name	Addr. (hex)	P	E	ro	Res.	Lower Limit	Upper Limit	Default Value	Unit
do	0	Output logic	2A00		•		1	0	7	0	
do	1	Output condition 1	2A01		•		1	0	10	2	
do	2	Output condition 2	2A02		•		1	0	10	4	
do	3	Output condition 3	2A03		•		1	0	10	4	
do	9	Select Out 1 condition (X1.1-X1.3)	2A09		•		1	0	7	1	
do	10	Select Out 2 condition (X1.21-X1.23)	2A0A		•		1	0	7	2	
do	11	Select Out 3 condition (DOUT)	2A0B		•		1	0	7	3	
do	17	Out 1 condition logic	2A11		•		1	0	7	0	
do	18	Out 2 condition logic	2A12		•		1	0	7	0	
do	19	Out 3 condition logic	2A13		•		1	0	7	0	
do	25	Output condition connection	2A19		•		1	0	7	0	

Output Logic – do. 0

The output logic enables inverting of the digital outputs. The parameter is bit coded. For each inverted output the corresponding decimal value is adjusted. If several outputs should be inverted, the sum of the decimal values is adjusted.

Bit-No	Decimal Value	Output	Terminal
0	1	Out 1 (Relay FLA, FLB, FLC)	X1.1, X1.2, X1.3
1	2	Out 2 (Relay RLA, RLB, RLC)	X1.21, X1.22, X1.23
2	4	Out 3 (Transistor output)	X1.14

Operating the Unit

Output Condition – do. 1/2/3

With do.1/2/3 the output conditions are adjusted and via parameters do. 9 to do. 25 assigned to Out 1, Out 2 and Out 3 :

Parameter Value	Output Function
0	always inactive
1	always active
2	Ready
3	activ
4	fatal error
5	DC-bus voltage > DC-bus voltage level
6	Apparent current > apparent current level
7	Signal PTC commutating choke
8	Signal heat sink temperature
9	Rate of loading (ru. 7) > utilization level (LE. 8–10)
10	OL counter > 80 %

Select Out Condition – do. 9/10/11, Out Condition Logic – do. 17/18/19

To activate an output condition to the corresponding output, the respective decimal value is adjusted in parameter "Select Out x condition". The state of the output condition is displayed in parameter ru.17. Each output condition can be inverted in parameter "Out x condition logic" by setting the corresponding decimal value .

Bit-No	Decimal Value	Output Condition
0	1	do. 1
1	2	do. 2
2	4	do. 3

Output Condition Connection – do. 25

do. 25 specifies whether the various output conditions should be interconnected by an 'AND-function' (Bit X = 1)or by an 'OR-function' (Bit X = 0'.

Bit-No.	Decimal Value	Output Condition
0	1	Out 1
1	2	Out 2
2	4	Out 3

5.4.2.9 Level (LE) – Parameter

Gr.	No	Name	Addr. (hex)	P	E	ro	Res.	Lower Limit	Upper Limit	Default Value	Unit
LE	8	Load level 1	2B08				1	0	200	50	%
LE	9	Load level 2	2B09				1	0	200	100	%
LE	10	Load level 3	2B0A				1	0	200	160	%
LE	12	Apparent current level 1	2B0C				0,1	0	370,0	0	A
LE	13	Apparent current level 2	2B0D				0,1	0	370,0	0	A
LE	14	Apparen current level 3	2B0E				0,1	0	370,0	0	A
LE	24	DC-bus voltage 1	2B18				1	0	1000	0	V
LE	25	DC-bus voltage 2	2B19				1	0	1000	0	V
LE	26	DC-bus voltage 3	2B1A				1	0	1000	0	V
LE	32	OL-prewarning	2B20				1	0	100	80	%
LE	38	Current hysteresis	2B26				0,1	0	370,0	0,0	A

Load Level – LE. 8/9/10

These parameter are the comparison values for the loading dependent output conditions of the digital outputs. Rate of loading level 1 is valid for output condition 1 etc.

Apparent Current Level – LE. 12/13/14

These parameters are the compensarison values for the apparent dependent output conditions of the digital outputs. Apparent current level 1 is valid for output condition 1 etc.

DC-Bus Voltage Level – LE. 24/25/26

These parameters are the comparison values for the DC-bus voltage dependent output conditions of the digital outputs. DC-bus voltage level 1 is valid for the output condition 1 etc.

OL-Prewarning – LE. 32

If the OL-counter (ru. 24) reaches 100 %, the error E.O is triggered. LE. 32 is the comparison value for the output condition „over load-prewarning“.

Current Hysteresis – LE. 38

With LE.38 the differential hysteresis for the apparent current level 1–3 (LE. 12–LE. 14) is adjusted.

5.4.2.10 Information (In) – Parameter

Gr.	No	Name	Addr. (hex)	P	E	ro	Res.	Lower Limit	Upper Limit	Default Value	Unit
In	0	Inverter type	2C00			•	tab.				
In	1	Inverter rated current	2C01			•	0,1	0	370,0		A
In	4	Software identification	2C04			•	0,1			b130	
In	5	Software date	2C05			•	0,1				
In	6	Configfile No.	2C06			•	1	0	255		
In	7	Serial No. (Date)	2C07			•	1	0	65535		
In	8	Serial No. (Counter)	2C08			•	1	0	65535		
In	9	Serial No. (AB-No. high)	2C09			•	1	0	65535		
In	10	Serial No. (AB-No. low)	2C0A			•	1	0	65535		
In	11	Customer No. (high)	2C0B			•	1	0	65535		
In	12	Customer No. (low)	2C0C			•	1	0	65535		
In	13	QS-Number	2C0D			•	1	0	255		
In	40	Last error	2C28			•	1	0	63	0	
In	41	Error counter OC	2C29			•	1	0	255	0	
In	42	Error counter OL	2C2A			•	1	0	255	0	
In	43	Error counter OP	2C2B			•	1	0	255	0	
In	44	Error counter OH	2C2C			•	1	0	255	0	

Type Feedback Unit – In. 0

The type of the feedback unit is displayed as hexadecimal number.
The individual bits have the following meaning

Bit-No.	Meaning
0	Voltage class 0 = 200 V 1 = 400 V
1–5	Size of the unit 0 = 16.R4. 1 = 14.R4. 2 = 18.R4. 3 = 22.R4.
6–9	Control type 0 = 0C.R4. 1 = 0B.R4
10–15	no meaning

Rated Current Feedback Unit – In. 1

Display of the rated current in A

Software-Identification – In. 4

The software version number and the control software are coded in parameter In.4.

Position	Meaning
1. position	Control hardware (B = 0B.R4.)
2. and 3. position	Software version (z. B. 10 = 1.0)
4. position	Special version (0 = Standard)

Software-Date – In. 5

Display of the software date. The value consists of the day, month and year. Only the last 2 digits of the year are shown.

Example: Display = 1507.7
Date = 15.07.97

Configfile Number – In. 6

Contains a software identifier used by KEB COMBIVIS to select the correct config-file. The configuration automatically starts when COMBIVIS is activated and the R4-S-feedback unit is connected.

Serial Number, Customer Number – In. 7/8/9/10/11/12

Serial number and customer number identify the R4-S-feedback unit.

QS-Number – In. 13

The QS-number contains internal informations.

Last Error – In. 40

In.40 displays the last error. E.UP is not stored.

Error Counter – In. 41/42/43/44

Error counters (for E.OC, E.OL, E.OP, E.OH) specify the total number of errors that occur of each type during operation. The maximum is 255.

6 Maintenance

No extraordinary maintenance is required.

7 Out of Service, Demounting and Waste Disposal

- Out of Service
1. ensure standstill of the drive – frequency inverter
 2. deactivate control – R4-S-regenerative unit, terminal ST
 3. disconnect mains – main contactor

Demounting When demounting the R4-S-regenerative unit please pay special attention to the capacitor discharge time!



Before starting to work, the safe isolation from supply must be verified with measurements in the system!

All installation and connection work must be done when the system is switched off!

The intermediate circuit capacitors are still charged with high voltage for a short period of time. The unit can be worked on again, after it has been switched off for 5 minutes.

Waste Disposal The R4-S-regenerative unit does not contain PCB elements.
The waste disposal items must be given to a special waste disposal!

8 Error Diagnosis

Error messages are always displayed at the R4-S-regenerative unit with „E.“ and the respective error in the display.

Error	Term	Reason	Control / Help
Undervoltage	E.UP	DC-bus voltage is decreased under the accepted value	
		- input voltage too small or instable - voltage losses in case of incorrectly cabling	
Overvoltage	E.OP	DC-bus voltage is increased over the accepted value	
		- input voltage too high - interference voltage at input	
Overcurrent	E.OC	Happens when the specified peak current is exceeded or an earth fault has been submitted.	
Overload	E.OL	Happens when the load is longer than the accepted time (see parameter ru. 24)	
		- error or overload in the application - R4-S-feedback unit is wrong dimensional	
Cooling time finished	E.nOL	After error display E.OL a cooling phase must be meet. This message is displayed after the cooling phase has finished. The error can be reset.	
Over-temperature	E.OH	Happens when the cooling temperature > 90 °C	
		- insufficient cooling - ambient temperature too high	
No over-temperature	E.nOH	No internal overtemperature error Error E.OH can be reset.	
Over-temperature commutation choke	E.dOH	External overtemperature error is triggered when the commutating choke is overheated	
		- Ambient temperature too high - Mains commutating choke dimension incorrectly	
External error	E.EF	If this message is displayed without the error signal defined by the user, the following can happen.	
		- Interference voltage at input	- Increasing of the digital noise filters (Param. di.0)
Synchronization	E.SYn	Happens when phases of the mains supply conductor and synchronization lines are incorrectly allocated.	
			- correction of assignment
Mains failure	E.net	Happens when mains supply conductors are not connected or during mains failure the break time is run off. (Parameter Pn. 59).	

9 Register

A		Interface	25	Standard Connection	15
Analog I/O - Parameter	36	K		Standard Operation	26
B		Keyboard Operation	26	Storage	6, 11
BUS- Operation	25	L		System Software COMBIVIS	26
C		Level - Parameter	41	T	
COMBIVIS	26	Local Operation	25	Technical Data	10
Connection of the Control	22	N		Terminal Strip X1	22, 23
Connection of the Power-circuit	13	Normal Use	6	Transport	11
Control - Parameter	33	Normal Use	6, 9	U	
Control Card	22	O		User Definition - Parameter	34
Control Signals	22	Operating Instructions	8	Unit is running	24
Control	22	Operation of the Unit	24	V	
D		Operation with Interface-Operator	25	Supply unit	17
Demounting	44	Operation during the Out of Service	44	W	
Device Identification	9	P		Waste Disposal	44
Digital Input - Parameter	37	Parallel Operation	15		
Digital Output - Parameter	39	Parameter	28		
Dimensions	12	Parameter Description	29		
E		Parameter Identification	26		
Electrical Connection	7	Parameter Number	26		
Enter Parameter	27	Parameter Summary	28		
Error Diagnosis	45	Parameter Value	27		
F		Power Circuit	14		
Field Conditions	9	Product Description	9		
FI-Protective Switch	8	Protection Equipment	8		
Free-programmable-Parameter	35	Protection - Parameter	32		
G		R			
General Signs	6	R4-S-Regenerative unit	12		
I		Run - Parameter	27		
Information - Parameter	42	S			
Initialization	24	Servicing	44		
Installation	7, 11	Short Description	47		
Installation Instructions	13	Special Displays	28		
Installation of the Unit	12				

10 DECLARATION OF CONFORMITY

EU -DECLARATION OF CONFORMITY

Document - Nr. / Month , Year : ENS_R4_B.DOC / 08 , 98

Manufacturer : Karl E. Brinkmann GmbH
Försterweg 36 - 38
D - 32683 Barntrop

Type of product : Inverter - type R4
Inverter size 14, 18, 22
Voltage category 400V AC

The above given product is in accordance with the following directives of the European Union :

Number : **Low voltage : 73 / 231 / EEC (and changes)**
Text : Directive on the approximation of the laws of the Member States
relating to all electrical equipment that has a voltage rating between
50V and 1000V AC or 75V and 1500V DC.

Further details regarding this standard are found in the annex.

CE marking on product: yes

Responsible : Karl E. Brinkmann GmbH
Försterweg 36 - 38
D - 32683 Barntrop

Place, date Barntrop, 17. August 1998

Issued by :



W.Hovestadt / Conformance Officer



W.Wiele / Technical Manager

The annex is part of this declaration.

This declaration certifies the conformity with the named directives, but does not contain any assurance of quality.

The safety instructions, described in part 1 of the instruction manual are to be followed.

11 Short Description

Standard Operation

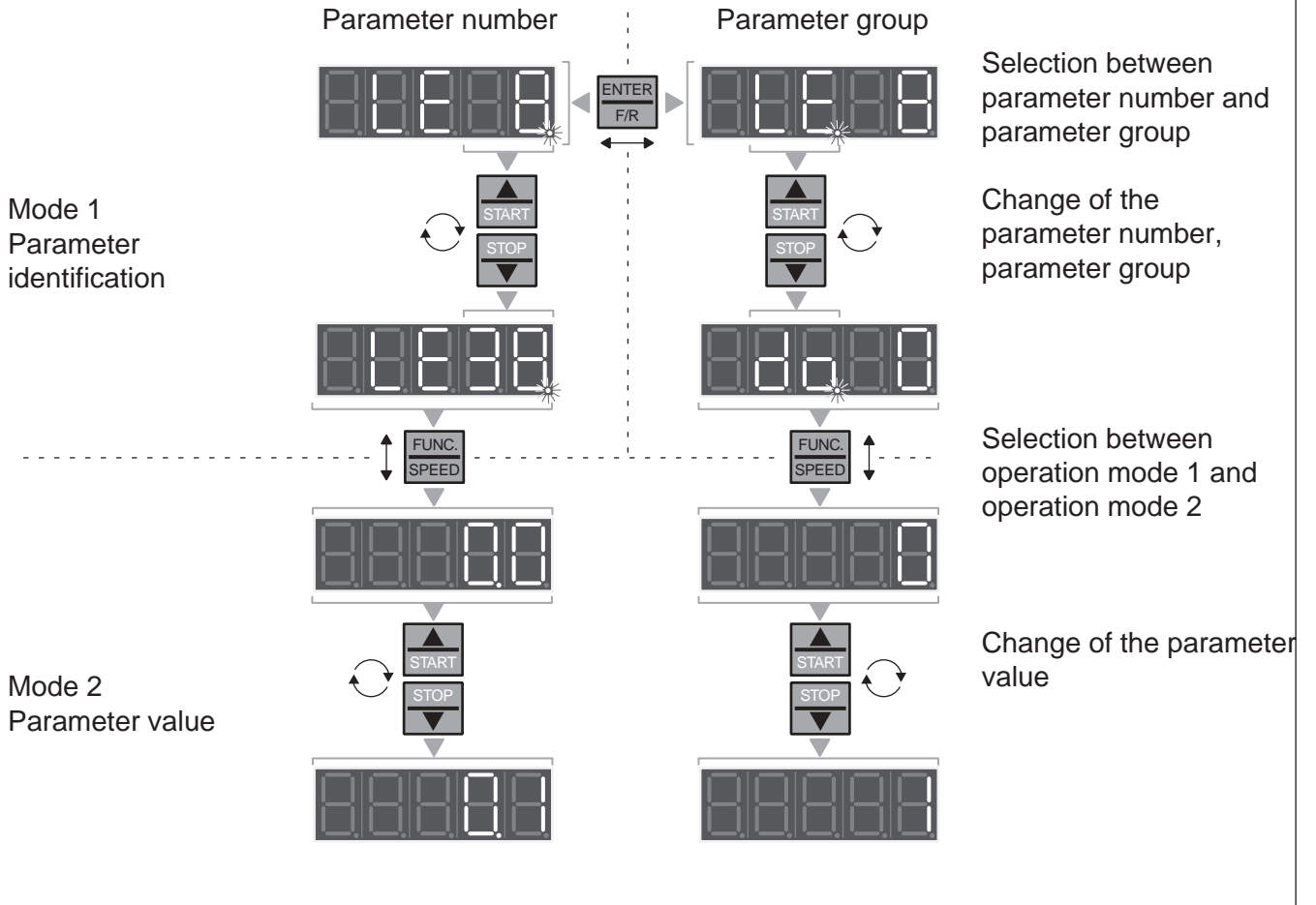

Error Message

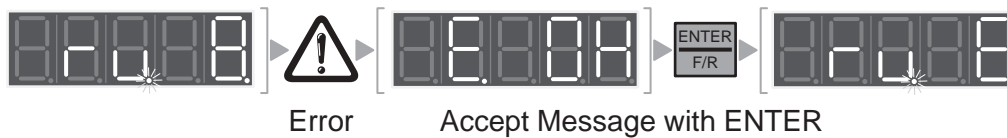



Vor der Auslieferung durchlaufen alle Produkte mehrfach eine Qualitäts- und Funktionskontrolle, so daß Fehler auszuschließen sind.

Bei Beachtung unserer Betriebsanleitung sind keine Störungen zu erwarten. Sollte sich trotzdem ein Grund zur Reklamation ergeben, setzen Sie sich bitte mit KEB in Verbindung!

Für Fehler, die aufgrund falscher Behandlung, falscher Lagerung oder sonstigen allgemeinen Irrtümern auftreten, übernehmen wir keine Verantwortung.

Prospekte, Kataloge und Angebote enthalten nur Richtwerte. Technische Änderungen jeder Art behalten wir uns vor. Alle Rechte vorbehalten.

Nachdruck, Vervielfältigung und fotomechanische Wiedergabe sind ohne schriftliche Genehmigung durch KEB auch auszugsweise verboten.



Prior to delivery all products pass several quality and performance inspections so that malfunctions can be ruled out.

When used in accordance with the operating instructions failure is most unlikely. However, if you have cause for complaint please contact KEB.

We do not accept the responsibility for failures due to misuse, wrong storage or similar causes.

Leaflets, catalogues and quotations contain only standard values. We reserve the right to make technical changes without obligation. All rights reserved.

Any piratic printing, mimeographing or photomechanical reproduction, even in extracts, is strictly prohibited.



Karl E. Brinkmann GmbH

Försterweg 36 - 38 • D - 32683 Barntrop
Telefon 00 49 / 52 63 / 4 01 - 0 • Fax 00 49 / 52 63 / 4 01 - 1 16
Internet: www.keb.de • E-mail: info@keb.de

KEB Antriebstechnik GmbH & Co. KG

Wildbacher Str. 5 • D - 08289 Schneeberg
Telefon 0049 / 37 72 / 67 - 0 • Telefax 0049 / 37 72 / 67 - 2 81
E-mail: info@keb-combidrive.de

KEB Antriebstechnik Austria GmbH

Ritzstraße 8 • A - 4614 Marchtrenk
Tel.: 0043 / 7243 / 53586 - 0 • FAX: 0043 / 7243 / 53586 - 21
Kostelni 32/1226 • CZ - 370 04 České Budejovice
Tel.: 00420 / 38 / 731 92 23 • FAX: 00420 / 38 / 733 06 97
E-mail: info@keb.at

KEB Antriebstechnik

Herenveld 2 • B - 9500 Geraadsbergen
Tel.: 0032 / 5443 / 7860 • FAX: 0032 / 5443 / 7898
E-mail: koen.detaeye@keb.de

KEB China

Xianxia Road 299 • CHN - 200051 Shanghai
Tel.: 0086 / 21 / 62350922 • FAX: 0086 / 21 / 62350015
Internet: www.keb-cn.com • E-mail: info@keb-cn.com

Société Française KEB

Z.I. de la Croix St. Nicolas • 14, rue Gustave Eiffel
F - 94510 LA QUEUE EN BRIE
Tél.: 0033 / 1 / 49620101 • FAX: 0033 / 1 / 45767495
E-mail: sfkeb.4@wanadoo.fr

KEB (UK) Ltd.

6 Chieftain Business Park, Morris Close
Park Farm, Wellingborough, GB - Northants, NN8 6 XF
Tel.: 0044 / 1933 / 402220 • FAX: 0044 / 1933 / 400724
Internet: www.keb-uk.co.uk • E-mail: info@keb-uk.co.uk

KEB Italia S.r.l.

Via Newton, 2 • I - 20019 Settimo Milanese (Milano)
Tel.: 0039 / 02 / 33500782 • FAX: 0039 / 02 / 33500790
Internet: www.keb.it • E-mail: kebitalia@keb.it

KEB - YAMAKYU Ltd.

15 - 16, 2 - Chome, Takanawa Minato-ku
J - Tokyo 108 -0074
Tel.: 0081 / 33 / 445-8515 • FAX: 0081 / 33 / 445-8215
E-mail: kebjt001@d4.dion.ne.jp

KEB Portugal

Lugar de Salgueiros - Pavilhao A, Mouquim
P - 4760 V. N. de Famalicao
Tel.: 00351 / 252 / 371 318 • FAX: 00351 / 252 / 371 320
E-mail: keb.portugal@netc.pt

KEB Taiwan Ltd.

1F, No.19-5, Shi Chou Rd., Tounan Town
R.O.C. - Yin-Lin Hsian / Taiwan
Tel.: 00886 / 5 / 5964242 • FAX: 00886 / 5 / 5964240
E-mail: keb_taiwan@mail.apol.com.tw

KEBCO Inc.

1335 Mendota Heights Road
USA - Mendota Heights, MN 55120
Tel.: 001 / 651 / 4546162 • FAX: 001 / 651 / 4546198
Internet: www.kebco.com • E-mail: info@kebco.com