

# C5

## COMBICONTROL C5

MADE  
IN  
GERMANY



# KEB COMBICONTROL C5 - Philosophy

Multi-axis drive applications are typically also demanding control tasks and require efficient control technique on system, process and field level.

Interfaces between control system and drive controller are essential factors for the successful conversion. The **current trend** for **open and closed loop** controls is moving towards **integrated solutions**: For optimum performance, open and closed loop tasks are shared between the system control and drive controller.

KEB has been standing for many years for „efficient power transmissions“. With expansion of work into upper control layer, the power become still more flexibility and is more applicable in the future.

KEB COMBICONTROL serves a product family of embedded control hardware, which is particularly designed for the needs of mechanical engineering and offers the user a functional tool for the compliance of his tasks.

	<b>Control</b>	<b>Drive controller</b>
<b>Programming</b>	SPS program according to IEC 61131-3; Motion control applications according to PLCopen	Parametrisation of technology functions
<b>Generation of programs</b>	User	Manufacturer (KEB)
<b>Programming tools</b>	IEC 61131 programming system (CoDeSys), Debugging tools, tTracing, online change	Parametrisation and start-up software (COMBIVIS))
<b>In- / outputs</b>	Supply (power, motor, control), digital / analog IOs, fast inputs, safety functions, miscellaneous encoder systems (resolver, Incremental encoder, absolut encoder), fieldbus interfaces, ethernet	

<b>Table of contents</b>	Page
<b>Automation with KEB COMBICONTROL C5</b>	3
<b>Technical data</b>	4
Hardware and functionality	5
<b>CoDeSys V. 2.3</b>	6
IEC 61131-3 programming languages	7
Editors	8
Visualisation	9
<b>Software overview</b>	10
Area of application	11
<b>Soft Motion</b>	12
<b>NC and CNC</b>	13
<b>Library</b>	14
<b>Applications</b>	16
<b>HMI - human machine interface</b>	18
<b>In- and output enhancements</b>	19
<b>Start-up</b>	20
<b>Service</b>	22
<b>Engineering</b>	23
<b>Addresses</b>	24

**KEB COMBICONTROL C5** provides a powerful control generation for your drive- and automation tasks, which is based on the leading engineering platform CoDeSys.

The major advantage of such systems based on latest 32 bit micro controllers is high operability and low resources reducing operating system whilst achieving high drive interface optimisation.

Together with the drive controllers **KEB COMBIVERT F5** and **B6** the **KEB COMBICONTROL C5** offers an

- universal
- modular
- standardized
- cost-effective

automation system. The special strengths are in the range of dynamic tasks with open-loop and closed-loop drives in series- and special machinery engineering.

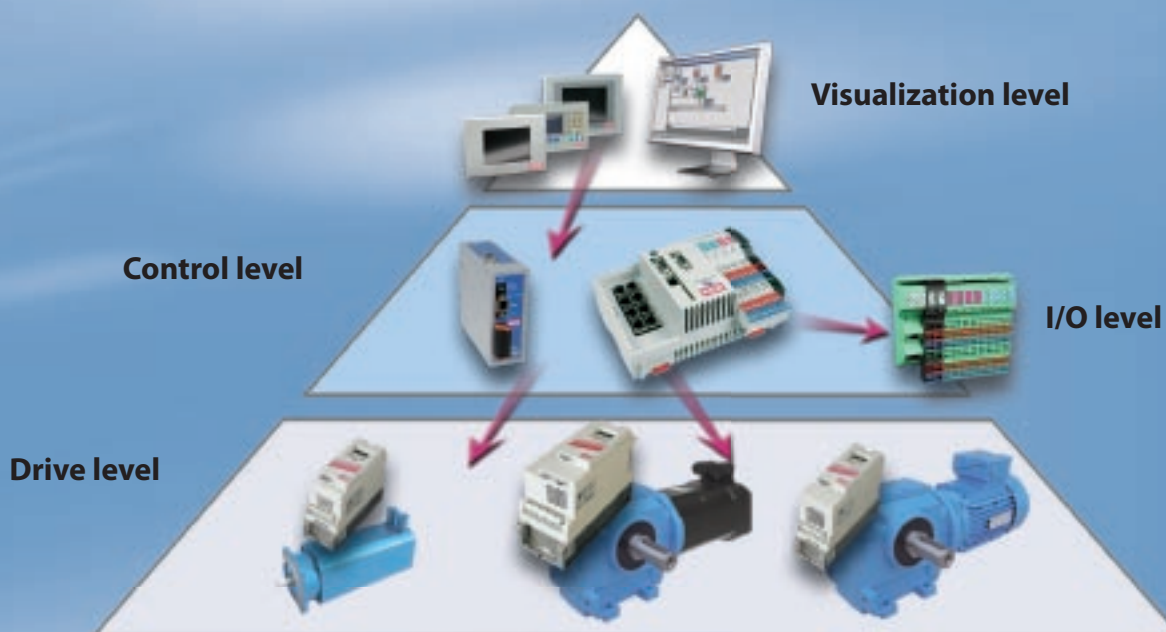

Typical PLC jobs			
○	IO-handling	○	Counter, Timer
○	Open and Closed-loop	○	Positioning
Additional jobs - Motion control			
○	SoftMotion	○	NC
○	Electronic gear	○	CNC
○	Real time ability	○	Cam disks
○	Communication	○	Expandability of in- and outputs etc.
○	Process data	○	Collect data
	Read and create files, data logging, error protocols, file transfer, ...		Measuring and operation data, encoder signals, image processing, ...
Human-Machine-Interface/ HMI			
○	graphical user surface	○	visualisation of processes

# KEB COMBICONTROL C5 - Technical Data

CPU based on 32 Bit Microcontroller, Renesas (Hitachi) SH2-A,

**Memory** SDram: 32 MB (therefrom 2 x 8 MB Code (online change), 12 MB data memory); Retain (NVRam): 31 kbyte

**Flash** 4 MB

**Speed of operation for 1k instructions** 0.18 ... 0.70 ms

**Supply** 18...30 VDC

**Input** 3 W - C5 Compact  
5 W - C5 Enhanced

**Control and error LEDs** 2

**RUN/STOP/RESET-switch** 1

**Real-time clock** 1



Version	C5 Compact	C5 Enhanced
<b>Interfaces</b>		
synchronous peripheral device to the drive	4x HSP5 (1 ms cycle time)	8x HSP5 (1 ms cycle time)
Serial interface	RS232/485 - DIN 66019II, Modbus RTU, Firmware-Flash	
Ethernet TCP/IP		
10/100 MBaud	2	1
Autospeed	yes	yes
Auto-crossover	yes	yes
Switch funktion	1	-
Fieldbus interface	16 Process data words IN 16 Process data words OUT and parameterizing channel	
CAN Open (Slave)	on request	1x optional
Profibus (Slave)	1x optional All certified PROFIBUS-Norm-slaves (DP-V0, DP-V1, DP-V2)	
Modbus / TCP	max. 64 (dependent on total Ethernet nodes)	
I/O extension	Ethernet/Modbus TCP - RTU	
Card reader (SD and MMC cards):	-	1
<b>Physical in-/outputs (on board)</b>		
electrically isolated	yes	
Digital IN	4	8
thereof High Speed	1x100µs scan time	
Digital OUT	4	8
Version	24V transistor	
max. current [A] / every output	0.7	
Connection	high-pole plug-in connector with cage-clamp terminal	cage-clamp terminal on snap-in frame/ fixed wiring
<b>Mechanical dimension</b>		
Volume [ccm]	844	1992
H x W x D [mm]	125 x 45 x 150	144 x 182 x 76
Assembly	35mm Mounting rail	
Weight [kg]	0.4	0.6
<b>Temperatures</b>		
Operating / storage [°C]	-10 ... 45 / -25 ... 70	



### C5 Compact

Run | Stop | Reset switch

Status and error LED's

24V voltage supply

Serial port RS232/485

I/O module  
4DI / 4DO  
8DI / 8DO

Ethernet interface  
 10/100 Mbit

Real time interface  
4 / 8 x HSP5

Card reader for SD/MMC

Fieldbus optional:  
 Profibus or CAN

### C5 Enhanced

### Connection of the drive controllers KEB COMBIVERT F5 and B6

Has cost matters, the drive and controls are connected via the standard drive interface bus  
 The connection of all drive controllers KEB COMBIVERT F5 is achieved via simple plug-in modules with RJ45 plugs and complete off-the-shelf cables.  
 Adapter and bus cable connect KEB COMBIVERT B6 diagnosis interface and C5 control.



		Part No.
<b>COMBIVERT F5</b>	Operator with RJ45 plug	00.F5.060-9002
	Bus cable 1m	00.F5.0C3-1010
	Bus cable 2m	00.F5.0C3-1020
	Bus cable 5m	00.F5.0C3-1050
	Bus cable 10m	00.F5.0C3-1100
<b>COMBIVERT B6</b>	Adapter RJ45 0.4 m	00.F5.0C0-0020
	Bus cable 1m	00.F5.0C0-4010
	Bus cable 2m	00.F5.0C0-4020
	Bus cable 5m	00.F5.0C0-4050



# KEB COMBICONTROL C5 - CoDeSys V. 2.3

IEC 61131-3 (old designation IEC 1131-3) is an international programming standard. It defines e.g.

- how data are declared
- how a program is structured
- Syntax and semantics of 6 different programming languages



CoDeSys is the global leading programming tool for the conversion of complex control tasks in the industrial environment and a complete development environment for control programs.

The worldwide standards for the programming are available in only one tool:

- Statement list (AWL)
- Structured Text (ST)
- Ladder diagram (LD)
- Sequential function chart (SFC)
- Function block diagram (FBD)
- Continuous Function Chart (CFC)

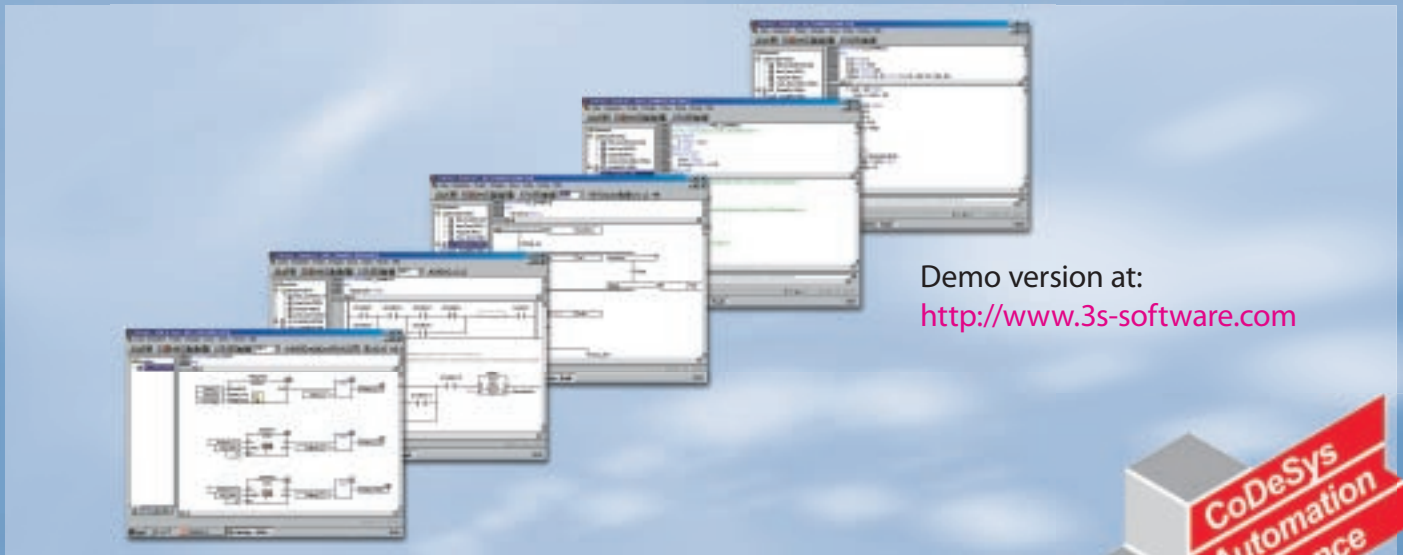

Demo version at:  
<http://www.3s-software.com>



## CoDeSys-Software contains the following elements:

- Editors
  - for all IEC programming languages (AWL, ST, CFC/FUP, etc.)
  - CAM / cam disc support
  - Computerized Numerical Controlled (CNC) - data processing
- Extensive libraries with standard modules (counter, timer, controller, etc.)
- Tools for test, simulation, error search and debugging of programs
  - Online change, debugging, breakpoint, single step, single cycle, force values, write values
- Integrated HMI interface for application-optimized design operator prompting
  - Graphical animated applications
  - Monitoring of variables
  - Oscilloscope function in real-time
- Library administrator
- File management of the PLC control
- Import/ Export of program modules
- Intelligent online documentation and assistance
- modern programming assistance in form of input assistants, syntax highlights and the Intellisense™ function.

## Text-based programming languages AWL and ST

### ST (structured text)

PASCAL-like high-level language, especially for condition-oriented programming (IF... THEN) and looping of compact program codes, simply to understand.

### AWL (statement list)

- Assembler language
- Operations work with special register (Accumulator, LD, ST)
- Widespread in Europe (Siemens-Standard)

## Grafic programming languages

- LD, SFC, FBD and CFC

### LD (ladder diagram)

- network-oriented
- especially for boolean terms
- american standard

### SFC (sequential function chart)

- optimally for step chain programming
- consists of steps and transitions (transition conditions)
- Program code is deposited in the steps (quasi subroutines)

### FBD (function block diagram)

### CFC (free-graphic function plan editor)

- graphic languages
- CFC: extension of FBD
- Elements can be shifted free
- Cross connections and feedbacks possible

```

IF temp<17 THEN
    heating_on :=TRUE;
ELSE
    heating_on :=FALSE;
END_IF

WHILE counter<>0 DO
    Var1 :=Var1*2;
    counter := counter-1;
END_WHILE
    
```

LD	17
ST	lint (*comment*)
GE	5
JMPC	next
LD	idword
EQ	istruct.sdword
STN	test
next:	

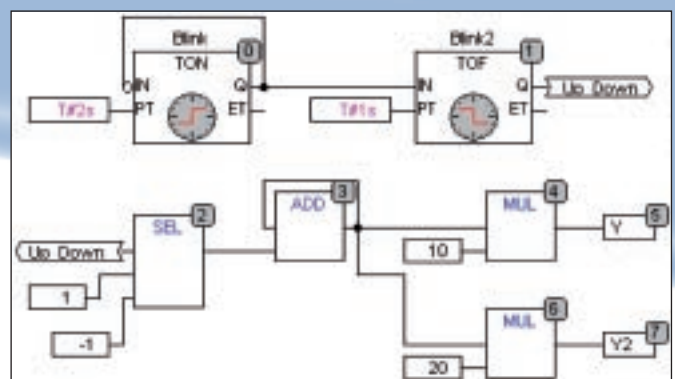
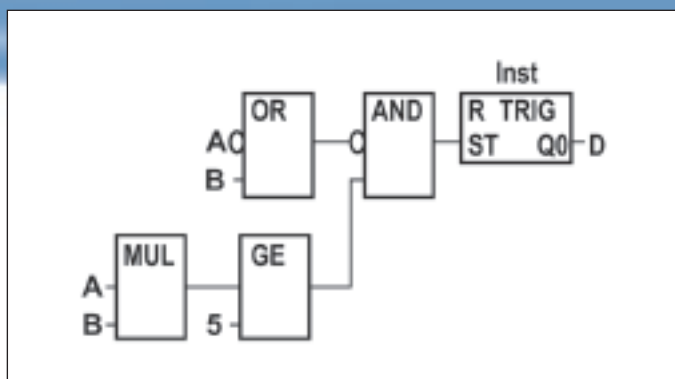
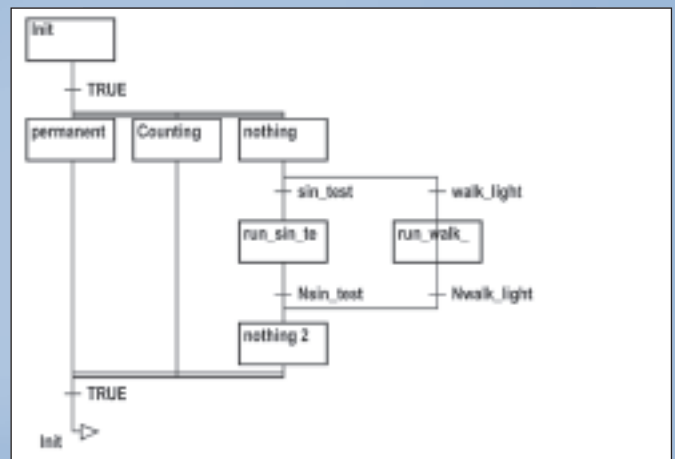
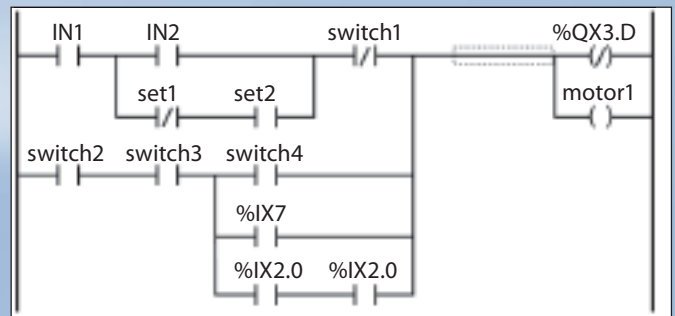





## Cam discs editor

Enter master and slave positions in points and straight lines

Electronic cam discs and cam-contactor group can be programmed with the cam discs editor by graph and table. Global data structures (CAM Data) are automatically generated by conversion of the project. The IEC program has access to these structures and converts the data structures by means of PLCopen standard module (library SM\_PLCOpen.lib) in contouring paths.

Display of speed and acceleration profile

## CNC Editor

The CNC editor in CoDeSys allows to program multidimensional movements simultaneously by graph and text according to the CNC language **DIN66025 (G-Code)**.

Name of the outline

Enter / display of the G-code

Graphic editor / display of the outline

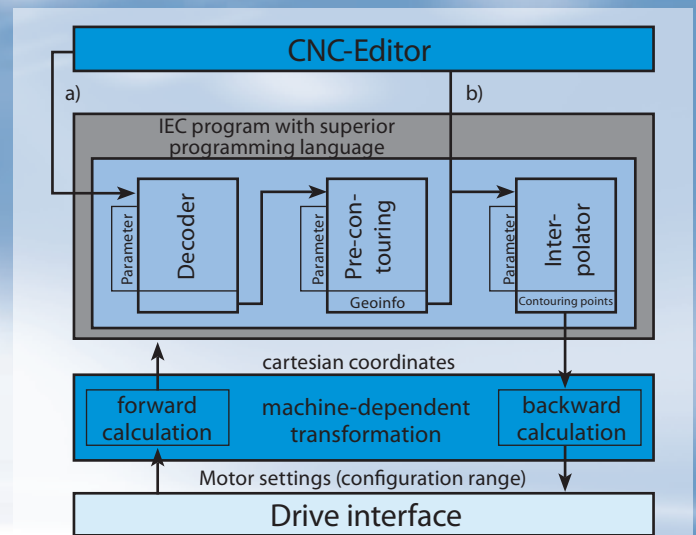

A global data structure (**CNC Data**) is automatically created for each generated contour, which is available in the IEC program for contouring control.

DXF import and conversion to contouring control is possible thanks the integrated import engine.



## Integrated HMI

A visualisation solution is integrated as standard within the programming system. It is able to display general operation functions, service or diagnostic, without additional costs.

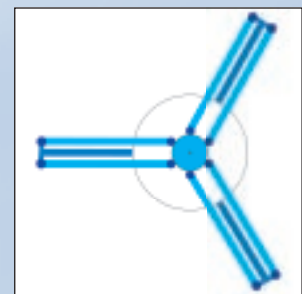
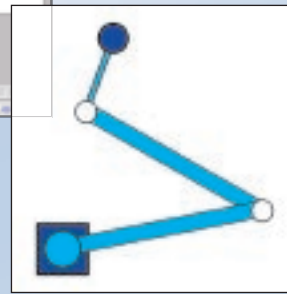
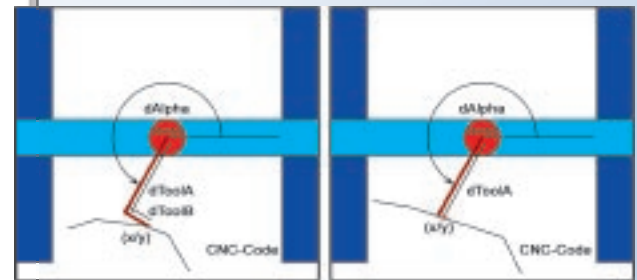
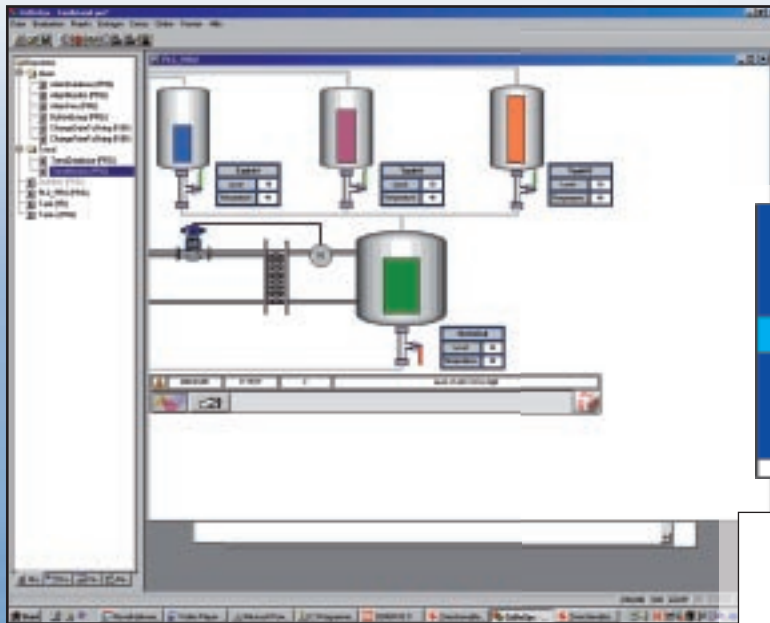

Numerous integrated modules are available for the application of **integrated HMI** and **CoDeSys HMI**, which contain various graphic elements for process image mapping.

## CoDeSys HMI

CoDeSys HMI is a run time system for the execution of comfortable visualisations, which were generated by CoDeSys programming system.

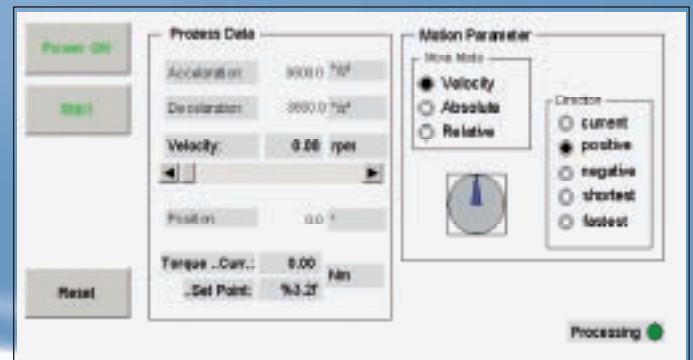
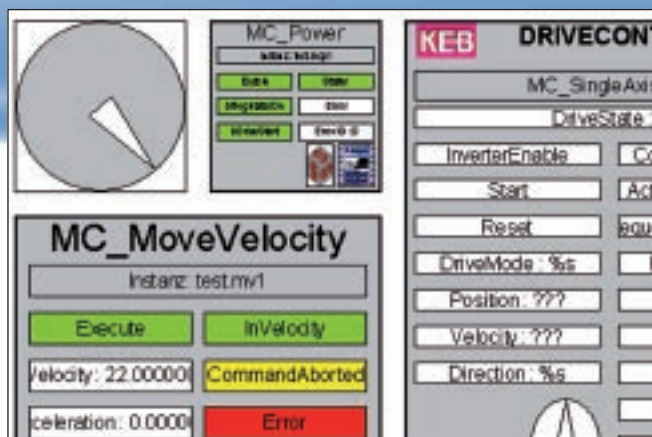

The optional software package may be invoked in a limited time demo version or purchased directly to CoDeSys.

# KEB COMBICONTROL C5 - functionalities

## Soft - SPS

includes the basic functionalities for process and systems control and simulates the conventional programmable controller (PLC) by software.

A large number of modules are applicable for process configuration. This enables the programmer to devote oneself to the application with tested working appliance.

## SoftMotion

the basis for high-dynamic motion processes in one or more levels. The KEB SoftMotion solution is a software modular system with motion modules, which enables simple implementation of motion applications. No detailed inverter know-how is necessary thanks to the ready to use kebc modules.  
(+) Error prevention by optimized and tested

software modules  
(+) simple handling with high reusability  
(+) small training period  
(+) communication to the drive controllers is done in fixed, synchronized time pattern via standard, low cost HSP5 interface.

**KEB SoftMotion is particularly suitable for the programming of tasks in single-axis or multi-axis applications with synchronized drives.**

### Properties:

- uniform, manufacturer generic programming standard for sequence of motions
- extensive library with ready-made standard motion modules
- reduced development period for complex motion sequences
- little detailed knowledge of the inverter parameters necessary, thus significant reduced training period
- simple integration and configuration of drives in the control program
- simple configuration of HSP5 bus (process data, cycle time etc.)
- total flexibility for development of new motion tasks

### Example: absolute positioning

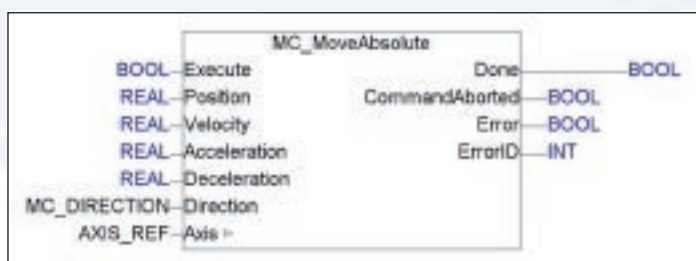

A positioning sequence can be generated in simple manner using graphic function chart editor (CFC) and the function bloc „move\_absolute“. The position to be approached with occurring edge at the Execute input is preset via variable „position“ on the left side of the module.

## NC and CNC

enables editing and processing of any contouring in the area. Based on the SoftMotion libraries the CNC package offers additional components for the processing of G-code and direct implementation of design data

## COMBICONTROL C5 as machine control unit

preferably for small and medium size machines and systems, where the control fulfills all functionalities for the process and the operator interface.

## COMBICONTROL C5 as aggregate control (plant section)

Segments of complete production units are controlled by a superior control for data management and visualization. Decentral aggregate controls realizes the partial automation in plant section which are connected via fieldbus. Solutions for the established versions PROFIBUS, CAN, RS 485 and Ethernet are available here.



## COMBICONTROL C5 with remote access maintenance

The control permits direct access to all drive controllers via modem, GSM, VPN server or dynamic DNS access.

## COMBICONTROL C5 as field bus node

Structure of a field bus section for 4 or 8 drives, which are connected central via the control as subordinated field bus range. This optimizes the connection costs for each axis and offers additionally the entire IEC 61131-3 programmability with own intelligence, e.g. for pre-start-up.

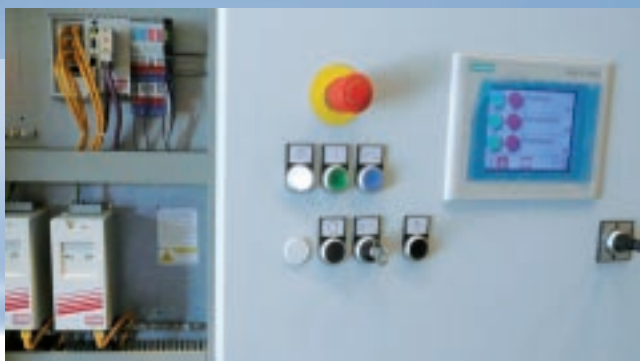

Page ok and read



## Highest performance with distributed intelligence

In case of motion control applications the drive axis are generally operated in contouring mode, i.e. process data are transmitted via synchronous serial communication with each cycle as new position setpoint.

- The respective speed follows from multiple interpolation between these setpoints.
- Position control is completely done in intelligent drive controller.
- The calculation of drive profiles for positioning, cam discs, etc. is done in the control.

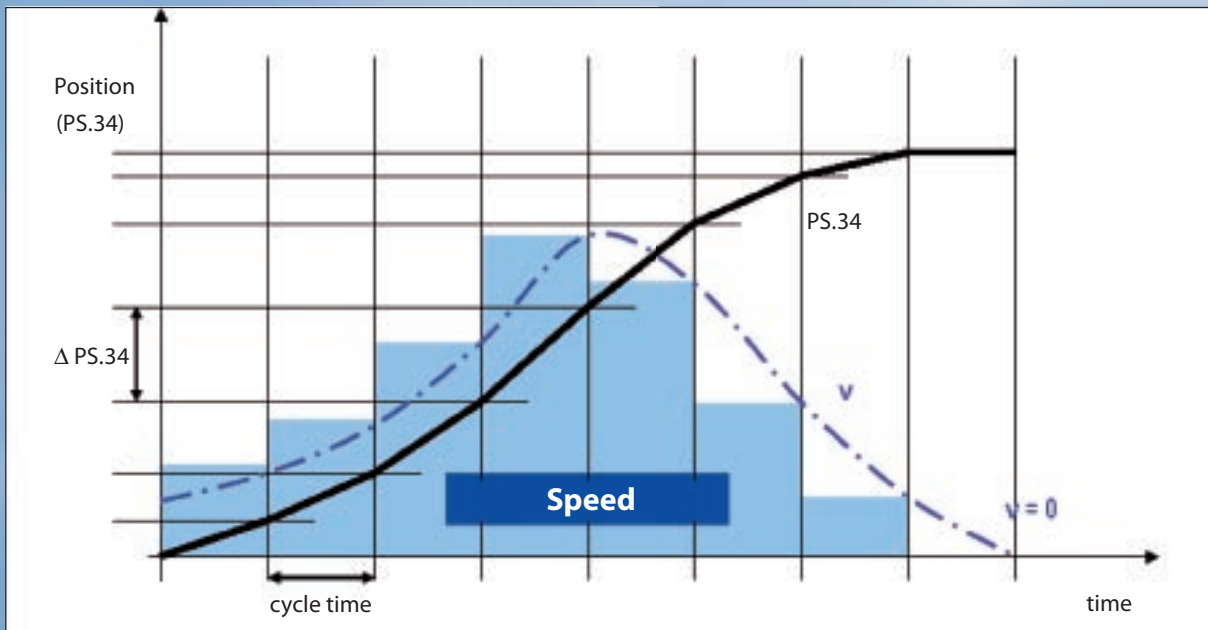

## KEB COMBICONTROL C5 operates the single drives with the cooperation of the SoftMotion libraries.

Advantages:

- even extremely complex drive tasks are solvable
- manufacturer independent programming of drive tasks
- Communication between the drives
- simple connection of ext. devices e.g. HMIs or I/O module
- simple extension of drive functionalities without change of the firmware
- Real time position synchronisation of 4 or 8 drive axis
- complete cam disc functionality immediately available
- Motion module according PLCopen / IEC 61131-3
- simple system configuration and bootup

## The KEB Soft Motion power spectrum includes the following components:

	Library(ies)	Assignment / functions
Drive Interface	SM_DriveBasic.lib	Communication between control program and drives
	KEBHSP5_485drive.lib	Interface from drive to CoDeSys Soft Motion
Virtual axis	Dummydrive.lib	enables offline application development inclusive test, without physically connected drives
PLCopen	SM_PLCopen.lib	Standard motion module according PLCopen
Error library	SM_Error.lib	output of error messages
CAM-Editor		Draft of cam discs and generation of the appropriate data structure



## CNC and SoftMotion power spectrum

Completely coordinated motion in the area, as they are used typically in machine tool, are dissolved to the axes in motion, NC and CNC control algorithms.

The associated software package includes extended modules for the following functions:

	Library(ies)	Assignment / functions
CNC library	SM_CNC.lib	contains the motion modules
Transformation library	SM_Trafo.lib	Adaption to various kinematics
Diagnostic library	SM_CNCDiagnostic.lib	Visualization of CNC data
File processing library	SM_FileFBs.lib	Reading of CNC data from files
CNC-Editor		Draft of CNC contouring and generation of the corresponding data structure

### Features in detail:

- 2,5D-CNC control for up to 9-dimensional motion
- manual generation of outlines with G-code (DIN 66025) and in the diagram editor
- direct import of DXF files
- Import and processing of CNC files from the flash memory at run time
- Influence of the positioning speed and -direction at run time
- Change of curves at run-time („on-the-fly“)
- miscellaneous modules for pre-processing motion
- different modules for calculation to motion kinetics
- comfortable visualization elements for representation in the user interface

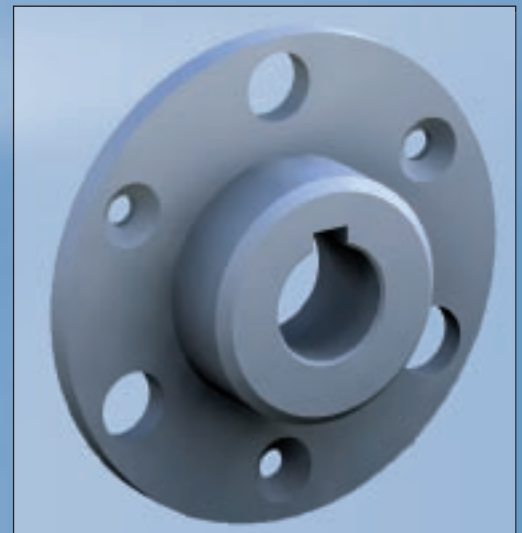

pre-processing motion tasks

### Example: gantry control

The application can be controlled via integrated visualization and the actual gantry position, data matrix and the axes status can be displayed.

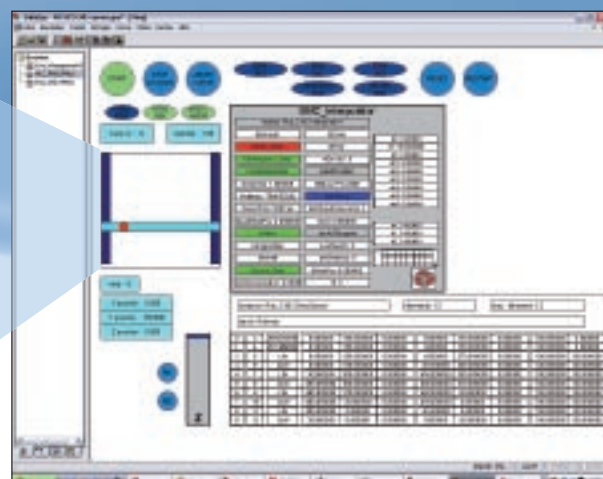
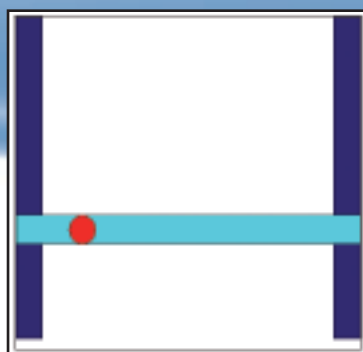

# KEB COMBICONTROL C5 - libraries

KEB specific function modules and functions are organized in libraries and are simply to use and manage in regards to extensions, updates and port.

## KEB\_Utility.lib

Functionality	short description	Released
FunctionBlock KEB_CheckMacID	is used to limit one C5 for one special project.	✓
FunctionBlock KEB_LowPassFilter	PT1-filter to smooth variables	✓
FunctionBlock KEB_TappetGenerator	generates tappet depending on master position, switch off delay for tappet can be programmed	✓
FunctionBlock KEB_SpeedResolution	returns the speed resolution of the drive	✓
Function KEB_StatusWord	returns string of KEB DRIVE STATUS WORD	✓
Function KEB_ControlWord	returns string of KEB DRIVE Control WORD	✓
FunctionBlock KEB_FastC5Input	is for frequency (scan time 100 µs) or pulse counter (limit: 3kHz) or interpolation of variables like positions within one C5 cycle	✓
FunctionBlock KEB_FlashCleanup	Flash cleanup during run-time of the C5 program	✓
FunctionBlock KEB_ResetAbsEncoderF5	reset absolute encoder position (ru.54) to zero	✓

## KEB\_SMC\_Utility.lib

Functionality	short description	Released
FunctionBlock KEB_MeasureDistance	when used on a rotatory axis it measures the covered distance and thereby regards the wrap.	✓
FunctionBlock KEB_ErrorManager	detection and plain text display of inverter errors, FB errors, bootup errors + error reset	✓
FunctionBlock KEB_BootupManager	detection and plain text display of drive errors during startup	✓
FunctionBlock KEB_SingleAxisControl	controls the axis in different axis modes	✓
Function KEB_CamAxisControl	controls the axis in different axis modes and camming	✓
Function KEB_PhasingAxisControl	controls the axis in different axis modes and phasing	✓
FunctionBlock KEB_GearAxisControl	controls the axis in different axis modes and gearing	✓
FunctionBlock KEB_Jog	with optional check of limit positions	✓
FunctionBlock KEB_BrakeControl	brake control through the C5	✓
FunctionBlock KEB_HomingOnBlock	homing one drive by moving it on block and relieving it afterwards	✓

It is reasonable for frequently recurring application requirements to organize individual functional blocks or applications in special libraries, in order to make it universal applicable in an easy manner. The actual KEB application library is continuously extended by new application fields.

## KEB\_<Application>.lib

Functionality	short description	Released
Library KEB_FlyingSaw	Application function block flying saw. Linear slave.	✓
Library KEB_TorqueWinder	Application library for torque winder	„field tested“
Library KEB_PickAndPlace	Application library for Pick-and-Place applications Virtual master (0...360°), 2 or 3 linear slaves	„field tested“



### Example: Application „Pick and Place“

1. Transport of goods via defined space coordinates to the destination point
2. coordinated motion with smoothening contouring curves for the minimization of the dynamic load and achievement of highest clock rates
3. optional rotation axis for correct adjustment of the goods at deposit
4. Termination and continuation of a contouring curve of any points in the area possible



### Customer specific library compilation

Codesys allows for the compilation of code into libraries, hence offering licencing and code protection solution for customer specific application.



# KEB COMBICONTROL C5 - Application examples

## SoftMotion: Electronical gear

Application: Software-based main driving shaft  
 KEB COMBICONTROL C5 controls a master axis. This can be illustrated with appropriate gear ratio or reductions on the slave axes.

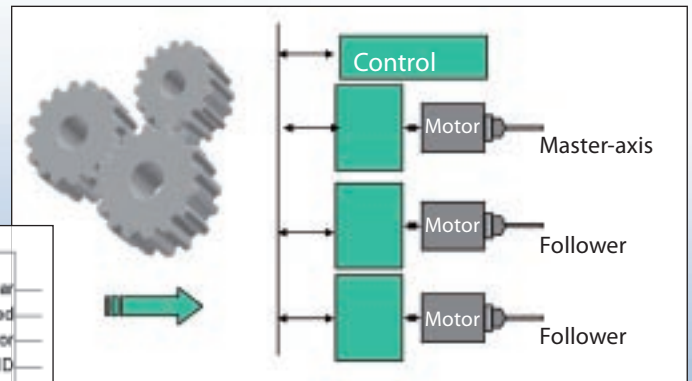

## SoftMotion: Electronical cam disc

Via cam disc function coupled axis are controlled with the function modules „MC\_CamTableSelect“ and „MC\_CAMIN“. The appropriate belonging axis values are stored in a table, which is selected with the module „MC\_CamTableSelect“ and mapped with the module „MC\_CAMIN“ to the slave axis.

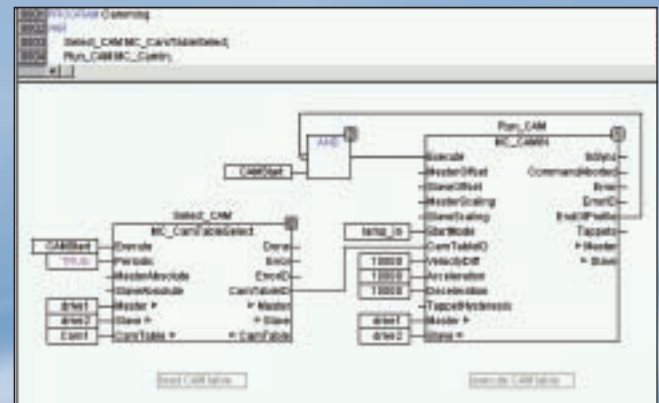

## Application: Food packaging

- 1 Evaluation of a picture processing system for presorting the commodity
- 2 Accurate spacer formation on the buffer conveyor band for defined handover.
- 3 Fill the packaging unit with free adjustable offset values.

16

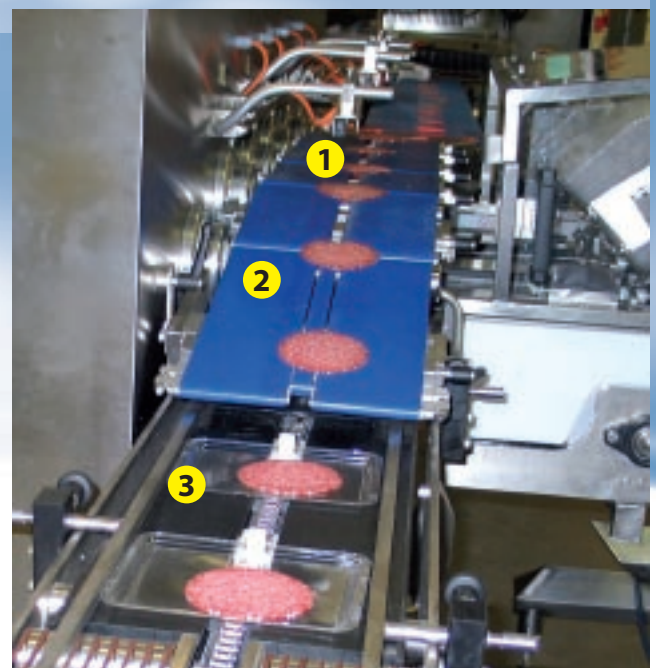



## CNC example: Plotter control

The graphic contouring points of the signature „C5 – READY FOR CNC !“ are automatically converted in G-code from the graphic tool of the CNC program editor .

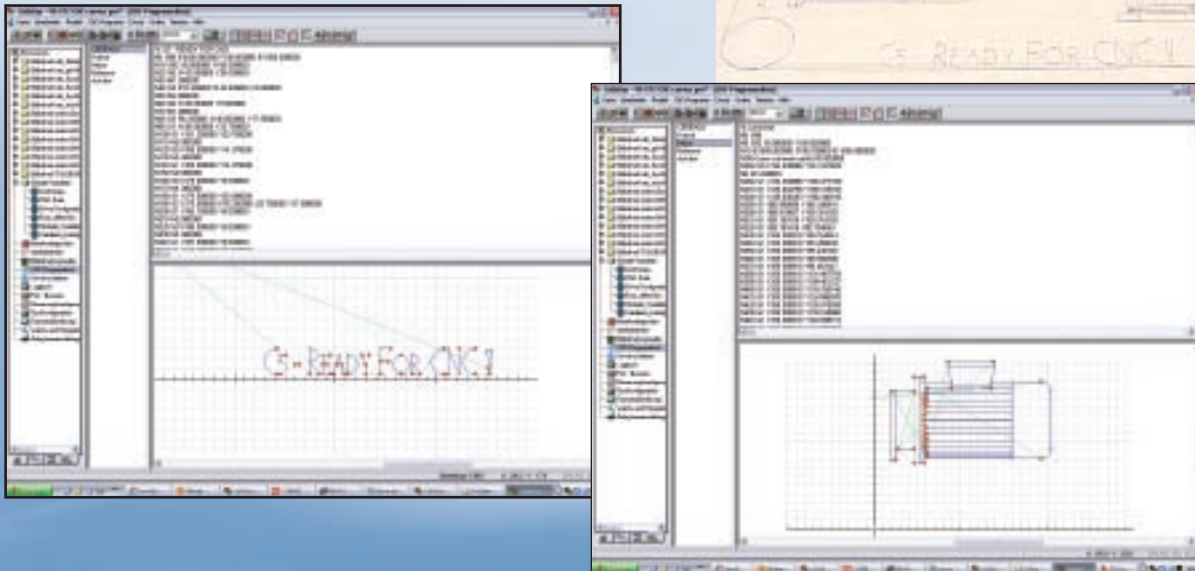

The position data are read in a second data set via DXF file (motor design), converted in G-code and stored in the control. This offers a simple solution to map digital points from the control to the actuator.

## CNC example: Delta kinematics with three axes

### Mechanical description:

- three symmetrical axes
- each with two symmetrical arm lengths
- central telescope guide bar

### Functional description:

- the function module „DeltaKin “transforms space coordinates into discrete axis values
- the Tool Center Point (TCP) determines the respective destination positions
- The target coordinates can be transferred either via teach-in or read from one/several CNC/ G-code-file(s).

### Typical application range:

Food industry, medical technology, etc.

small mass => very small cycle times possible

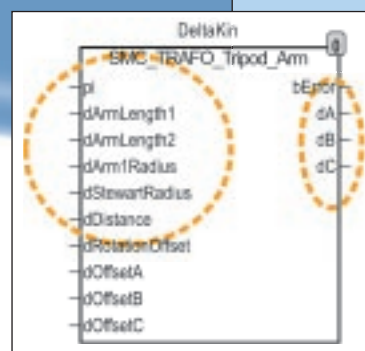
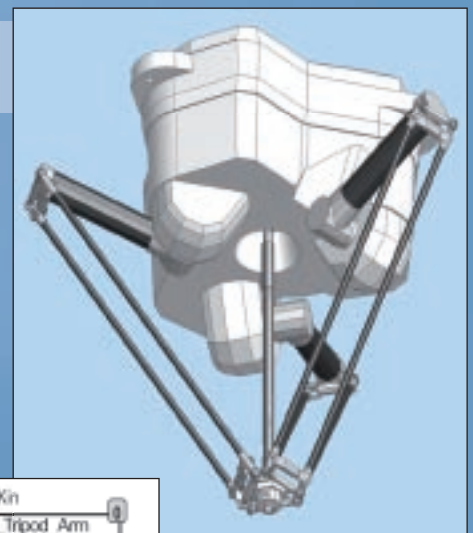

# KEB COMBICONTROL C5 - HMI

Operator guidance and machine controls are a key parameter to successful systems. Comfortable, easy to reach and representative data are major requirements for the end user. This is especially true for specific machinery.



KEB COMBICONTROL C5 are HMI ready with regards to standard communication protocols:

- **Ethernet**
  - Modbus TCP/UDP
  - 3S Arti
- **RS 232/ 485**
  - Modbus RTU
  - DIN 66019-II
- **OPC Server**

The interfaces and protocols support several commercial operator units.

Dependent on the requirements of the application:

- 2 or multiline function displays
- high resolution monochrome or colored diagram displays
- HMI client
- PC based HMI

useable without and with keyboard and touch function.



The structure of the operator units (HMI) need to be integrated in all levels of the control hierarchy. Operation and monitoring can also be implemented trouble-free across-the-control.

Standardized software modules and sample application provide significant help to the newcomer.



Input and output of process variables, switching signals status messages, control units, travel transducer, etc. are standard elements of the input and output logic in machines.

In addition to the available encoder, analog and digital inputs and outputs, the **KEB COMBICONTROL C5** control concept offers the possibility to integrate further external modules.

Depending on the machine concept with central or local control structure, connection may be achieved via

- Modbus TCP/ UDP**
- Modbus RTU**

In operation with higher level process controls **PROFIBUS** or **CAN** connection is also possible.

Modular modules or block modules are available for the following physical versions:

- DIGITAL IN / OUT
- ANALOG IN/ OUT
- Setpoint signals 0...10V, 0(4)...20mA

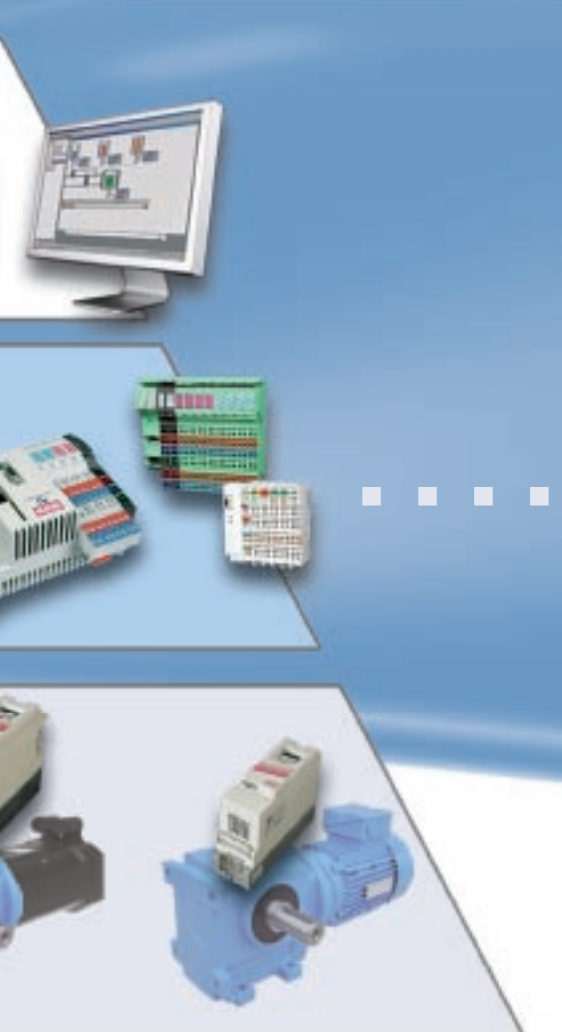

Multivendor capability software modules and example applications also help simple integration.



# KEB COMBICONTROL C5 - start-up

## Parameterizing with KEB COMBIVIS

KEB COMBIVIS used together with the KEB COMBICONTROL C5 offers a fast and easy solution to view and set all machine drives in one single window for easy initial setup of the drives.

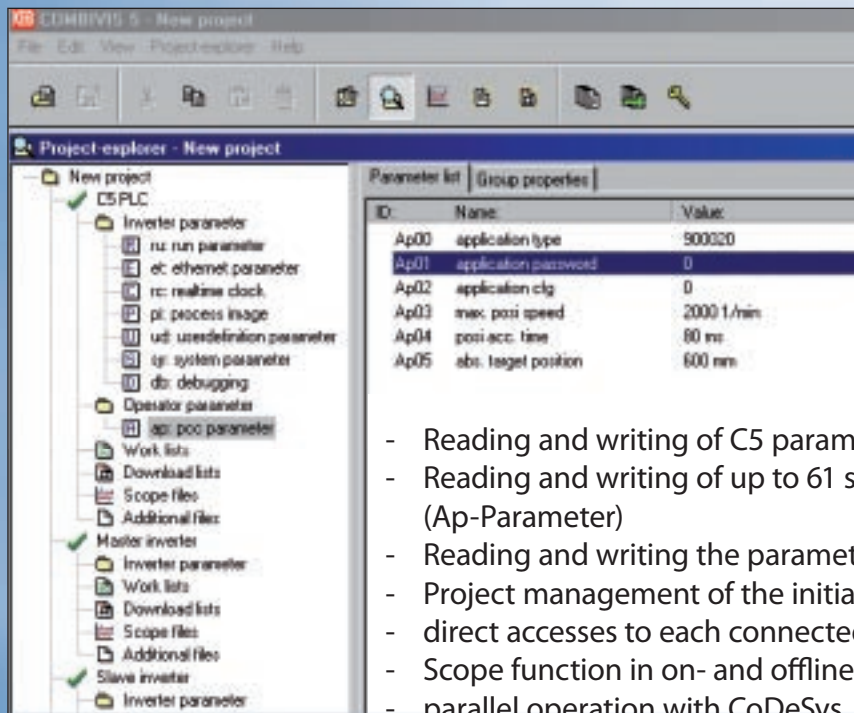

- Reading and writing of C5 parameters
- Reading and writing of up to 61 self-defined C5 variables (Ap-Parameter)
- Reading and writing the parameters of all connected axes
- Project management of the initial settings of a complete unit
- direct accesses to each connected single axis by the control
- Scope function in on- and offline mode of the drive axes
- parallel operation with CoDeSys

## Parameterizing with CoDeSys and SoftMotion

Comfortable tools are designed for selection and connection of drive axes as well as for adaption of process variables of the machine. These permit e.g.

- Assignment of the unit initial setting (download lists)
- Assignment of conversion factors defining relative variables of the application

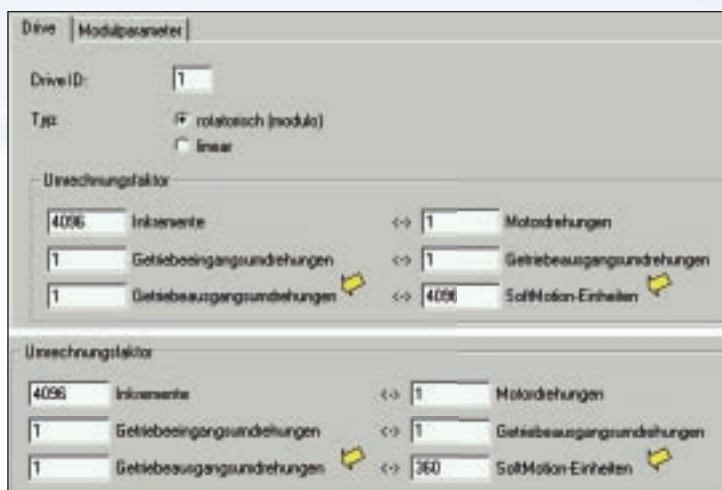

**Example 1:**  
SoftMotion-unit = increments

**Example 2:**  
SoftMotion-unit = angular degree



## Diagnostics with CoDeSys trace recording

The trace recording permits a visual illustration of any parameters with up to 8 channels simultaneously within one project.

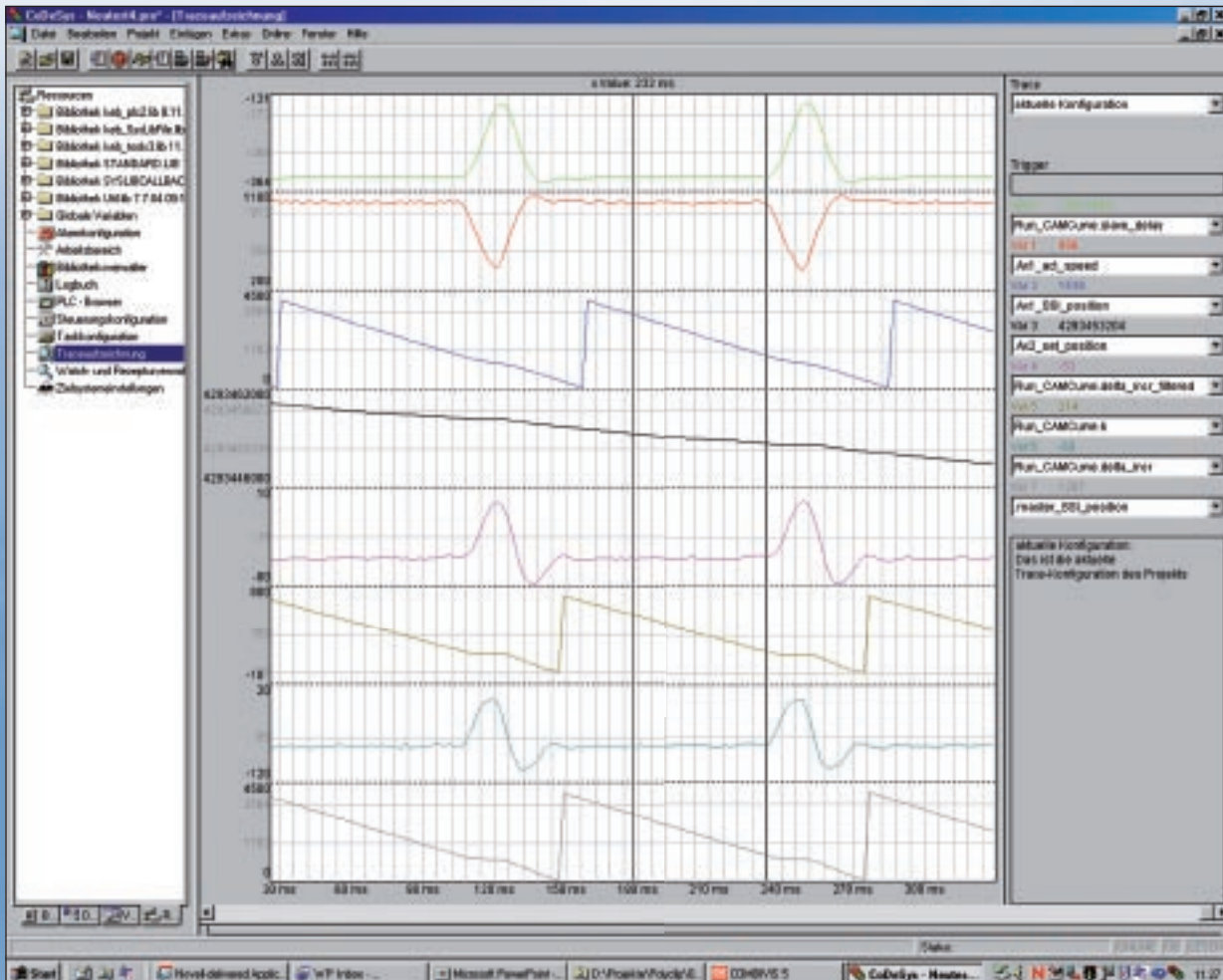

## Watch- and recipe management

Values of selected variables can be displayed by using watch- and recipe management. The watch- and recipe management enables that the variables are initialized with defined values ('write recipe'). Also actual data sets of the control can be read in and stored as pre-assignment in the watch- and recipe management ('read recipe').

This functions are helpful e.g. for adjustment and detection of control parameters.

## Log functionality

Log functionality offers the possibility to store different user actions, internal procedures, status changes and exceptional conditions chronological during the online mode. Accurate error reverse prosecutions support the diagnostics of events, fault times are reduced thereby and improved evaluation of possible causes is permitted.

# KEB COMBICONTROL C5 - Service

## Exchange of hardware

Consequent use of plug-in connection method simplifies changing of the modules and reduces the error potential by wrong wiring in service situation.

Plug connections also offer a comfortable prefabrication of necessary cables and enables a significant reduced assembly time in practise.

### Backup-solution via SD/MMC – memory card.

„Backups“ of the complete application can be created and loaded if required with SD/MMC memory card functions. Machine program updates and replacement are therefore facilitated. The program image stored on the SD card can be loaded into the **KEB COMBICONTROL C5** by simple manipulation of the front switch, without the need of specific equipement. This ensures high machine availability.



## Remote-access - remote maintenance

For diagnostics and maintenance **KEB COMBICONTROL C5** may be easily integrated in a standard architecture via:

- Modem connection
- VPN server / VPN client (e.g.: openVPN, freeware)
- Wireless GSM
- Dynamic DNS access .

Direct remote access to the controller and associated drive is therefore possible permitting fault finding or fine tuning of the application and drives in a cost effective manner.



## Service

Should you not have temporary sufficient **engineering resources** available

A motivated and efficient team supports you in your work and realizes complete solutions competently and efficiently. To be a power spectrum in detail:

- **Concept generation**  
... take load and transfer in functional specification
- **Design**  
... convert the physical requirements in dimensionings with the experiences of drive technology
- **Programming**  
... configuration of the total application in code



- **Start-up and commissioning**  
... directly on customer site
- **Training**  
... of the technical departments as basis of internal advancements
- **Documentation**  
... supply of application manuals

Qualified engineers are available within our national and international sales units to discuss and answer your specific application requirements and questions.

### Your direct contact person in the head office:

#### Application technology open-loop controls

Antonius Thier	+49 (0)5263/401-709
Walter Pieper	+49 (0)5263/401-257
Michael Zacharewicz	+49 (0)5263/401-226
Torben Fischer	+49 (0)5263/401-464

E-mail: [combicontrol@keb.de](mailto:combicontrol@keb.de)



# Headquarters

**Karl E. Brinkmann GmbH**  
Försterweg 36 - 38  
D-32683 Barntrop  
Internet: [www.keb.de](http://www.keb.de)

Tel.: + 49 (0) 5263 401-0  
Fax: + 49 (0) 5263 401-116  
E-mail: [info@keb.de](mailto:info@keb.de)

## SUBSIDIARIES

### AUSTRIA

KEB Antriebstechnik  
Austria GmbH  
Ritzstraße 8  
A - 4614 Marchtrenk  
Tel.: +43 (0)7243 53586-0  
Fax: +43 (0)7243 53586-21  
E-mail: [info@keb.at](mailto:info@keb.at)  
Internet: [www.keb.at](http://www.keb.at)

### CHINA

KEB Power Transmission  
Technology (Shanghai) Co. Ltd.  
No. 435 QianPu Road  
Songjiang East Industrial Zone  
CN - 201611 Shanghai, PR. China  
Tel.: +86 (0)21 37746688  
Fax: +86 (0)21 37746600  
E-mail: [info@keb.cn](mailto:info@keb.cn)  
Internet: [www.keb.cn](http://www.keb.cn)

### GERMANY

KEB Antriebstechnik GmbH  
Wildbacher Straße 5  
D - 08289 Schneeberg  
Tel.: +49 (0)3772 67-0  
Fax: +49 (0)3772 67-281  
E-mail: [info@keb-combidrive.de](mailto:info@keb-combidrive.de)

### FRANCE

Société Française KEB  
Z.I. de la Croix St. Nicolas  
14, rue Gustave Eiffel  
F - 94510 LA QUEUE EN BRIE  
Tel.: +33 (0)149620101  
Fax: +33 (0)145767495  
E-mail: [info@keb.fr](mailto:info@keb.fr)  
Internet: [www.keb.fr](http://www.keb.fr)

### GREAT BRITAIN

KEB (UK) Ltd.  
6 Chieftain Business Park,  
Morris Close  
Park Farm, Wellingborough  
GB - Northants, NN8 6 XF  
Tel.: +44 (0)1933 402220  
Fax: +44 (0)1933 400724  
E-mail: [info@keb-uk.co.uk](mailto:info@keb-uk.co.uk)  
Internet: [www.keb-uk.co.uk](http://www.keb-uk.co.uk)

### ITALIA

KEB Italia S.r.l.  
Via Newton, 2  
I - 20019 Settimo Milanese (Milano)  
Tel.: +39 02 33535311  
Fax: +39 02 33500790  
E-mail: [info@keb.it](mailto:info@keb.it)  
Internet: [www.keb.it](http://www.keb.it)

### JAPAN

KEB - Japan Ltd.  
15 - 16, 2 - Chome  
Takanawa Minato-ku  
J - Tokyo 108 - 0074  
Tel.: +81 (0)33 445-8515  
Fax: +81 (0)33 445-8215  
E-mail: [info@keb.jp](mailto:info@keb.jp)  
Internet: [www.keb.jp](http://www.keb.jp)

### RUSSIA

KEB RUS Ltd.  
Krasnokazarmeny proezd 1  
Metrostation „Aviamotornay“  
RUS - 111050 Moscow  
Tel.: +7 (0)495 7952317  
Fax: +7 (0)495 6453913  
E-mail: [info@keb.ru](mailto:info@keb.ru)  
Internet: [www.keb.ru](http://www.keb.ru)

### USA

KEB America, Inc  
5100 Valley Industrial Blvd. South  
USA - Shakopee, MN 55379  
Tel.: +1 (0)952 2241400  
Fax: +1(0)952 2241499  
E-mail: [info@kebameric.com](mailto:info@kebameric.com)  
Internet: [www.kebameric.com](http://www.kebameric.com)

**Representative offices in** Belgien • Korea • Schweden • Spanien

**Further partner for ...**

Australia • Belgium • Bolivia • Brazil • Chile • Czech Republic • Denmark • Egypt • Greece • Hungary • India • Iran • Indonesia • Israel • Kazakhstan • Malaysia • Morocco • Netherlands • New Zealand • Pakistan • Poland • Portugal • Romania • Singapore • Slovakia • South Africa • Spain • Sweden • Switzerland • Thailand • Tunisia • Turkey • Ukraine • Uzbekistan

... [www.keb.de/en/contact/keb-worldwide.html](http://www.keb.de/en/contact/keb-worldwide.html)



© KEB 00.00.000-51C5 / 11-2008 • Subject to technical changes!

